



HV09

Product Objective Specification

T-52-13-05

32-Channel Symmetric Row Drivers

Ordering Information

Device	Package Options			
	44 J-Lead Quad Ceramic Chip Carrier	44 J-Lead Quad Plastic Chip Carrier	Die in waffle pack	44 - Lead Ceramic J-Bend (MIL-STD-883 Processed*)
HV0923	HV0923DJ	HV0923PJ	HV0923X	RBHV0923DJ

\* For Hi-Rel process flows, refer to page 5-3 of the Databook.

Features

- Processed with HVCMOS<sup>®</sup> technology
- Symmetric row drive (reduces latent imaging in ACTFEL displays)
- Output voltages up to 230V
- Very low-power level shifting
- Source/Sink current 200mA
- Shift Register Speed 4MHz
- Pin-programmable shift direction
- 44-lead plastic & ceramic surface-mount packages

General Description

The HV09 is a low-voltage serial to high-voltage parallel converter with push-pull outputs. It is especially suitable for use as a symmetric row driver in AC thin-film electroluminescent (ACTFEL) displays. The HV09 offers 32 output lines, a direction (DIR) pin to give CW or CCW shift register loading, output enable (OE), and polarity (POL) control. After DATA INPUT is entered (on the falling edge of CLOCK), a logic high will cause the output to swing to V<sub>PP</sub> if POL is high, or to GND if POL is low.

Absolute Maximum Ratings

Supply voltage, V <sub>DD</sub> <sup>1</sup>	-0.3V to +15V	
Supply voltage, V <sub>PP</sub>	-0.3V to +250V	
Logic input levels	-0.3V to V <sub>DD</sub> +0.3V	
Ground current <sup>2</sup>	1.5A	
Continuous total power dissipation <sup>3</sup> :	Ceramic	1500mW
	Plastic	1200mW
Storage temperature range	-65°C to +150°C	
Lead temperature 1.6mm (1/16 inch) from case for 10 seconds	260°C	

Notes:

1. All voltages are referenced to GND.
2. Duty cycle is limited by the total power dissipated in the package.
3. For operation above 25°C ambient, derate linearly to 70°C at 12mW/°C.

11

# Electrical Characteristics

(over recommended operating conditions of  $V_{DD} = 12V$  and  $V_{PP} = 230V$  unless noted)

T-52-13-05

## DC Characteristics

Symbol	Parameter	Min	Max	Units	Conditions	
$I_{DD}$	$V_{DD}$ supply current		10	mA	$f_{CLK} = 4MHz$	
			3	mA	$f_{CLK} = 100kHz$	
$I_{PPO}$	High voltage quiescent supply current		4	mA	1 output high <sup>1</sup>	
			500	$\mu A$	All Outputs low	
			500	$\mu A$	High Z state	
$I_{DDQ}$	Quiescent $V_{DD}$ supply current		100	$\mu A$	All $V_{IN} = GND$ or $V_{DD}$	
$V_{OH}$	High-level output	HV <sub>OUT</sub>	200	V	$I_O = -200mA$	
		Data out	11	V	$I_O = -500\mu A$	
$V_{OL}$	Low-level output	HV <sub>OUT</sub>		30	V	$I_O = 200mA$
		Data out		1	V	$I_O = 500\mu A$
$I_{IH}$	High-level logic input current		1	$\mu A$	$V_{IH} = 12V$	
$I_{IL}$	Low-level logic input current		-1	$\mu A$	$V_{IL} = 0V$	
$V_{OC}$	High voltage output clamp voltage		-2	V	$I_O = -200mA$	

Note 1. The total number of ON outputs times the duty cycle must not exceed the allowable  $P_D$ .

## AC Characteristics ( $V_{DD} = 12V, T_C = 25^\circ C$ )

Symbol	Parameter	Min	Max	Units	Conditions
$f_{CLK}$	Clock frequency		4	MHz	
$t_W$	Pulse duration clock high or low	125		ns	
$t_{SUD}$	Data set-up time before falling clock	100		ns	
$t_{HD}$	Data hold time after falling clock	100		ns	
$t_{SUC}$	Setup time clock low before $V_{PP}\uparrow$ or $GND\downarrow$	300		ns	
$t_{SUE}$	Setup time enable high before $V_{PP}\uparrow$ or $GND\downarrow$	300		ns	
$t_{SUP}$	Setup time polarity high or low before $V_{PP}\uparrow$ or $GND\downarrow$	300		ns	
$t_{HC}$	Hold time clock high after $V_{PP}\uparrow$ or $GND\downarrow$	500		ns	
$t_{HE}$	Hold time enable high after $V_{PP}\uparrow$ or $GND\downarrow$	300		ns	
$t_{HP}$	Hold time polarity high or low after $V_{PP}\uparrow$ or $GND\downarrow$	300		ns	
$t_{DHL}$	Delay time high to low level output from clock		150	ns	$C_L = 30pF$
$t_{DLH}$	Delay time low to high level output from clock		200	ns	$C_L = 30pF$
$t_{THL}$	Transition time high to low level serial output		200	ns	$C_L = 30pF$
$t_{TLH}$	Transition time low to high level serial output		100	ns	$C_L = 30pF$
$t_{ONH}$	High level turn-on time HV outputs from enable		1000	ns	$I_O = -200 mA, V_{OH} = 220V$ $R_L = 500 \Omega$ to $120V$
$t_{ONL}$	Low level turn-on time HV outputs from enable		500	ns	$I_O = 200 mA, V_{OH} = 130V$ $R_L = 500 \Omega$ to $30V$
$t_{OFFH}$	High level turn-off time HV outputs from enable		1000	ns	$I_O = -200 mA, V_{OH} = 220V$ $R_L = 500 \Omega$ to $120V$
$t_{OFFL}$	Low level turn-off time HV outputs from enable		500	ns	$I_O = 200 mA, V_{OH} = 130V$ $R_L = 500 \Omega$ to $30V$
	Slew rate, $V_{PP}$ or $GND$		45	V/ $\mu s$	With one active output driving a 4.7 nF load to $V_{PP}$ or $GND$

**Recommended Operating Conditions**

*T-52-13-05*

Symbol	Parameter	Min	Max	Units	
V <sub>DD</sub>	Logic supply voltage	10.8	13.2	V	
V <sub>PP</sub>	High voltage supply		230	V	
V <sub>IH</sub>	High-level input voltage	V <sub>DD</sub> = 10.8V	8.1	V	
		V <sub>DD</sub> = 13.2V	9.9		
V <sub>IL</sub>	Low-level input voltage	V <sub>DD</sub> = 10.8V	2.7	V	
		V <sub>DD</sub> = 13.2V	3.3		
f <sub>CLK</sub>	Clock frequency		4	MHz	
T <sub>A</sub>	Operating free-air temperature	Commercial	0	+70	°C
		Military HI-Rel (RB)	-55	+125	°C

**Note:**

Power-up sequence should be the following:

1. Connect ground.
2. Apply V<sub>DD</sub>.
3. Set all inputs (Data, CLK, Enable, etc.) to a known state.
4. Apply V<sub>PP</sub>.

Power-down sequence should be the reverse of the above.

**Input and Output Equivalent Circuits**

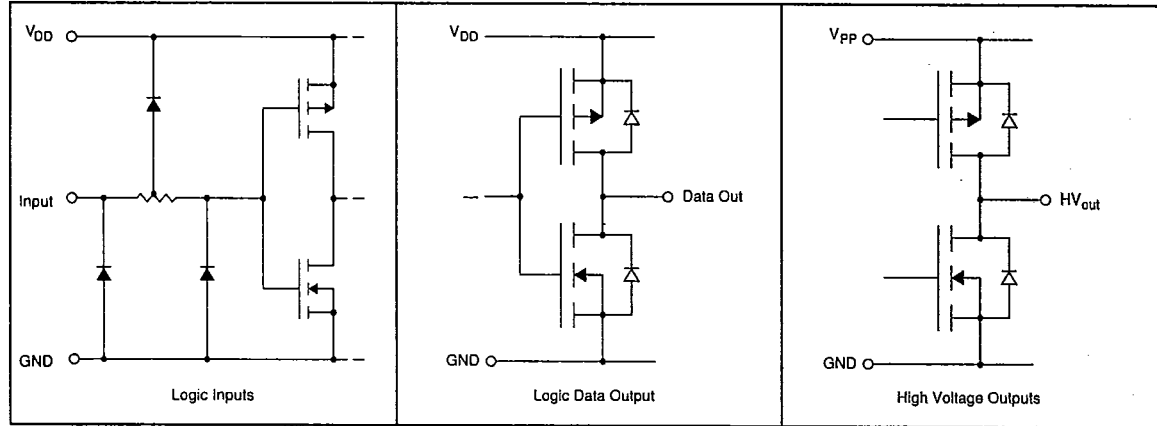

Switching Waveforms

T-52-13-05

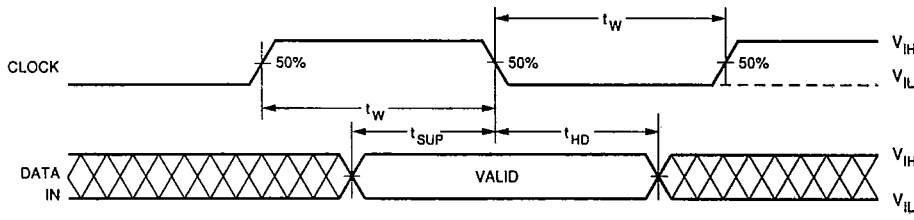

Input Timing Voltage

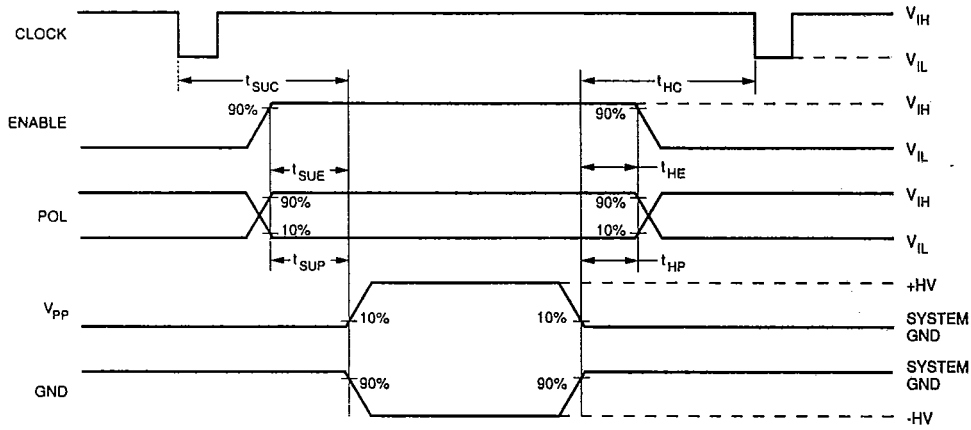

Control Input Timing Voltage

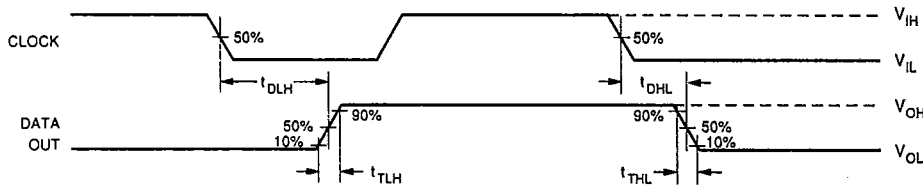

Voltage Waveforms for Propagation Delay Times,  
Clock to Data Out

Functional Block Diagram

T-52-13-05

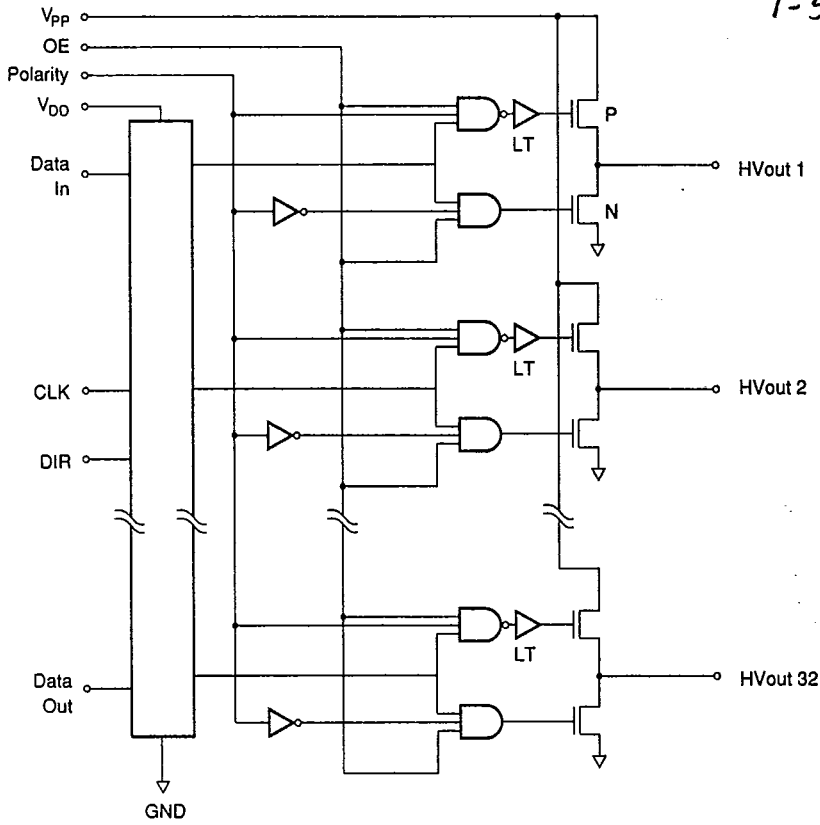

LT = Level Translator

11

Function Table

Outputs	Inputs					Outputs		
	CLK	DIR	Data	POL	OE	Shift Reg	HV Outputs	Data Out
O/P HIGH	X	X	H	H	H	*	H	*
O/P OFF	X	X	L	H	H	*	HIGH-Z	*
O/P LOW	X	X	H	L	H	*	L	*
O/P OFF	X	X	L	L	H	*	HIGH-Z	*
All O/P OFF	X	X	X	X	L	*	All O/P HIGH-Z	*
Load S/R, set DIR	↓	L	X	X	X	$Q_n \rightarrow Q_{n+1}$	*	$Q_{32}$
	↓	H	X	X	X	$Q_n \rightarrow Q_{n-1}$	*	$Q_1$
I/O Relation	—	L	$D_{IOA}$	X	X	—	—	$D_{IOB}$
	—	H	$D_{IOB}$			—	—	$D_{IOA}$

Notes:

H = logic high level, L = logic low level, X = irrelevant, ∅ = high-to-low transition.  
 $Q_1 = HV_{out} 1$ ,  $Q_n = HV_{out} (n)$ , etc.  
 \* = dependent on previous state and whether an O/P or S/R command occurred.

Pin Configurations

Package Outline

T-52-13-05

HV09  
44 Pin J-Lead Package

Pin	Function	Pin	Function
1	HV <sub>OUT</sub> 16/17	23	DIR
2	HV <sub>OUT</sub> 15/18	24	V <sub>DD</sub>
3	HV <sub>OUT</sub> 14/19	25	Polarity
4	HV <sub>OUT</sub> 13/20	26	Data I/O B
5	HV <sub>OUT</sub> 12/21	27	GND
6	HV <sub>OUT</sub> 11/22	28	V <sub>PP</sub>
7	HV <sub>OUT</sub> 10/23	29	HV <sub>OUT</sub> 32/1
8	HV <sub>OUT</sub> 9/24	30	HV <sub>OUT</sub> 31/2
9	HV <sub>OUT</sub> 8/25	31	HV <sub>OUT</sub> 30/3
10	HV <sub>OUT</sub> 7/26	32	HV <sub>OUT</sub> 29/4
11	HV <sub>OUT</sub> 6/27	33	HV <sub>OUT</sub> 28/5
12	HV <sub>OUT</sub> 5/28	34	HV <sub>OUT</sub> 27/6
13	HV <sub>OUT</sub> 4/29	35	HV <sub>OUT</sub> 26/7
14	HV <sub>OUT</sub> 3/30	36	HV <sub>OUT</sub> 25/8
15	HV <sub>OUT</sub> 2/31	37	HV <sub>OUT</sub> 24/9
16	HV <sub>OUT</sub> 1/32	38	HV <sub>OUT</sub> 23/10
17	V <sub>PP</sub>	39	HV <sub>OUT</sub> 22/11
18	GND	40	HV <sub>OUT</sub> 21/12
19	Data I/O A	41	HV <sub>OUT</sub> 20/13
20	Output Enable	42	HV <sub>OUT</sub> 19/14
21	Clock	43	HV <sub>OUT</sub> 18/15
22	GND	44	HV <sub>OUT</sub> 17/16

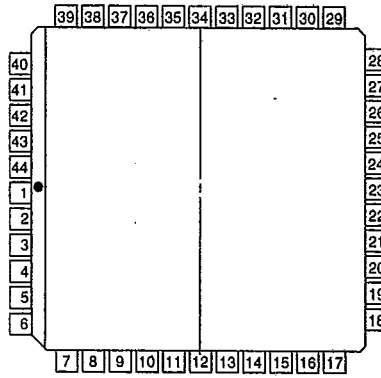

top view  
44-pin J-lead Package

Note:  
Pin designation for DIR = L/H  
For DIR = H, Pin 1 is HV<sub>OUT</sub> 16, for DIR = L Pin 1 is HV<sub>OUT</sub> 17