



REMOTE CONTROL COMMANDER IC

■ GENERAL DESCRIPTION

The NJU6005 is a remote control commander IC, and generates the control code according to the key input of 8 x 8 matrix. It contains auto clear circuit, carrier generator, key input / key scan output circuit, extension code generator, data ROM and operated single power supply.

The NJU6005 has the stand-by mode using auto clear function with external capacitance.

The transmission code is using a Pulse Position Modulation (PPM) method and its transmission by the IR-LED. Maximum 80 - pattern output is available by programming the PLA and custom code ROM.

■ PACKAGE OUTLINE

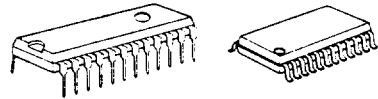

NJU6005L

NJU6005M

■ FEATURES

- Transmission Code -- Pulse Position Modulation
- Generating Pattern -- Fixed by PLA and ROM
- Frame Number Setting -- 1 to 8 frame
- Internal Oscillation Circuit
- Power On Initialization
- Stand-by Mode -- 1 μ A Max.
- Low Power Consumption
- Operating Voltage -- 2.0 ~ 3.6V
- Package Outline -- DMP / SDIP 24
- C-MOS Technology

■ PIN CONFIGURATION

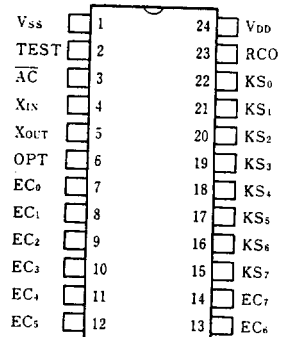

■ BLOCK DIAGRAM

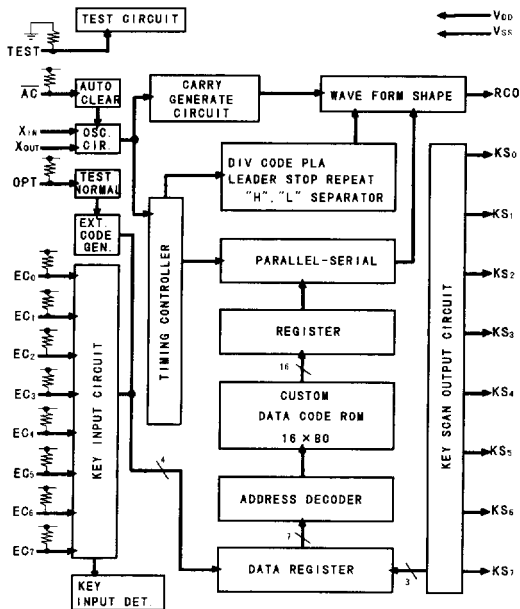

■ TERMINAL DESCRIPTION

NO.	SYMBOL	FUNCTION
1	V _{SS}	GND
2	TEST	Testing Terminal (Normally OPEN, Internal Pull-down Resistance)
3	AC	Auto Clear Terminal (Internal Pull-up Resistance) Power on initialization is executed by connecting a capacitance to this.
4, 5	X _{IN} , X _{OUT}	Oscillation Inverter Input / Output Terminal (Internal Feedback Resistance) This connects a ceramic resonator.
6	OPT	Extension Key Input Terminal (Internal Pull-up Resistance) The keys are extended by connecting with switches between the OPT terminal and the key scan terminals KS ₆ and KS ₇ .
7~14	EC ₀ ~EC ₇	Key Matrix Input Terminal (Internal Pull-up Resistance) The RCO output is started when this key input is perceived and after 36msec period.
15~22	KS ₇ ~KS ₀	Key Scan Output Terminal Key scan time is 0.21msec. In case using maximum 32 keys, all scan time is about 36msec in high speed.
23	RCO	Remote Control Oscillation Terminal The pulse line of the transmission cord modulated by carrier wave is output. This pulse operates the IR-LED by driving the base of an external NPN transistor.
24	V _{DD}	Power Supply Voltage range is wide from 2.0V to 3.6V, therefore it is two batteries (3.0V) enough to operate. Except for key operation, operating current (stand-by current) is dropped under 1uA by stopping oscillation.

10

■ FUNCTIONAL DESCRIPTION
(1) Oscillation Circuit

The NJU6005 incorporates an internal oscillation circuit, therefore, when a ceramic resonator is connected the terminals X_{IN} and X_{OUT}, carrier wave of a transmission signal is generated inside.

(2) Key Matrix

The key of 8×8 matrix consists the inputs EC₀ to EC₇ and the key scan outputs KS₀ to KS₇. And Keys are extended by combining the OPT terminal and the terminals KS₆ to KS₇.

(3) Transmission Signal
(3-1) Data Format

The NJU6005 has 14 kinds of the data transmission format as shown in Table 1.



Table 1 Data Transmission Format In NJU6005

Wave Type	Date Line Up																																																																												
1	<table border="1"> <tr> <td colspan="8">Custom Code 8bit</td> <td colspan="8">Custom Code 8bit</td> <td colspan="8">Data Code 8bit</td> <td colspan="8">Data Code 8bit</td> </tr> <tr> <td>Leader</td><td>C1</td><td>C2</td><td>C3</td><td>C4</td><td>C5</td><td>C6</td><td>C7</td><td>C8</td> <td>C1</td><td>C2</td><td>C3</td><td>C4</td><td>C5</td><td>C6</td><td>C7</td><td>C8</td> <td>D1</td><td>D2</td><td>D3</td><td>D4</td><td>D5</td><td>D6</td><td>D7</td><td>D8</td> <td>D1</td><td>D2</td><td>D3</td><td>D4</td><td>D5</td><td>D6</td><td>D7</td><td>D8</td> <td>Stop</td><td>Repeat</td> </tr> </table>	Custom Code 8bit								Custom Code 8bit								Data Code 8bit								Data Code 8bit								Leader	C1	C2	C3	C4	C5	C6	C7	C8	C1	C2	C3	C4	C5	C6	C7	C8	D1	D2	D3	D4	D5	D6	D7	D8	D1	D2	D3	D4	D5	D6	D7	D8	Stop	Repeat									
Custom Code 8bit								Custom Code 8bit								Data Code 8bit								Data Code 8bit																																																					
Leader	C1	C2	C3	C4	C5	C6	C7	C8	C1	C2	C3	C4	C5	C6	C7	C8	D1	D2	D3	D4	D5	D6	D7	D8	D1	D2	D3	D4	D5	D6	D7	D8	Stop	Repeat																																											
2	<table border="1"> <tr> <td colspan="8">Custom Code 8bit</td> <td colspan="8">Data Code 8bit</td> </tr> <tr> <td>Leader</td><td>C1</td><td>C2</td><td>C3</td><td>C4</td><td>C5</td><td>C6</td><td>C7</td><td>C8</td> <td>D1</td><td>D2</td><td>D3</td><td>D4</td><td>D5</td><td>D6</td><td>D7</td><td>D8</td> <td>Stop</td> </tr> </table>	Custom Code 8bit								Data Code 8bit								Leader	C1	C2	C3	C4	C5	C6	C7	C8	D1	D2	D3	D4	D5	D6	D7	D8	Stop																																										
Custom Code 8bit								Data Code 8bit																																																																					
Leader	C1	C2	C3	C4	C5	C6	C7	C8	D1	D2	D3	D4	D5	D6	D7	D8	Stop																																																												
3	<table border="1"> <tr> <td colspan="8">Data Code 8bit</td> </tr> <tr> <td>D1</td><td>D2</td><td>D3</td><td>D4</td><td>D5</td><td>D6</td><td>Stop</td> </tr> </table>	Data Code 8bit								D1	D2	D3	D4	D5	D6	Stop																																																													
Data Code 8bit																																																																													
D1	D2	D3	D4	D5	D6	Stop																																																																							
4	<table border="1"> <tr> <td colspan="10">Data Code 10bit</td> </tr> <tr> <td>D1</td><td>2</td><td>3</td><td>4</td><td>5</td><td>6</td><td>7</td><td>8</td><td>9</td><td>10</td> <td>Stop</td> </tr> </table>	Data Code 10bit										D1	2	3	4	5	6	7	8	9	10	Stop																																																							
Data Code 10bit																																																																													
D1	2	3	4	5	6	7	8	9	10	Stop																																																																			
5	<table border="1"> <tr> <td colspan="8">Custom Code 8bit</td> <td colspan="8">Custom Code 8bit</td> <td colspan="8">Data Code 8bit</td> <td colspan="8">Data Code 8bit</td> </tr> <tr> <td>Leader</td><td>C1</td><td>C2</td><td>C3</td><td>C4</td><td>C5</td><td>C6</td><td>C7</td><td>C8</td> <td>C1</td><td>C2</td><td>C3</td><td>C4</td><td>C5</td><td>C6</td><td>C7</td><td>C8</td> <td>D1</td><td>D2</td><td>D3</td><td>D4</td><td>D5</td><td>D6</td><td>D7</td><td>D8</td> <td>D1</td><td>D2</td><td>D3</td><td>D4</td><td>D5</td><td>D6</td><td>D7</td><td>D8</td> <td>Stop</td> </tr> </table>	Custom Code 8bit								Custom Code 8bit								Data Code 8bit								Data Code 8bit								Leader	C1	C2	C3	C4	C5	C6	C7	C8	C1	C2	C3	C4	C5	C6	C7	C8	D1	D2	D3	D4	D5	D6	D7	D8	D1	D2	D3	D4	D5	D6	D7	D8	Stop										
Custom Code 8bit								Custom Code 8bit								Data Code 8bit								Data Code 8bit																																																					
Leader	C1	C2	C3	C4	C5	C6	C7	C8	C1	C2	C3	C4	C5	C6	C7	C8	D1	D2	D3	D4	D5	D6	D7	D8	D1	D2	D3	D4	D5	D6	D7	D8	Stop																																												
6	<table border="1"> <tr> <td colspan="5">Address5</td> <td colspan="5">Data6</td> <td colspan="3">Option2</td> <td colspan="3">Mask1</td> <td colspan="3">Check1</td> <td colspan="5">Address5</td> <td colspan="5">Data6</td> <td colspan="3">Option2</td> <td colspan="3">Mask1</td> <td colspan="3">Check1</td> </tr> <tr> <td>A1</td><td>A2</td><td>A3</td><td>A4</td><td>A5</td> <td>D1</td><td>D2</td><td>D3</td><td>D4</td><td>D5</td><td>D6</td> <td>1</td><td>0</td><td>2</td><td>M</td><td>1</td><td>H</td><td>1</td> <td>Stop</td> <td>A1</td><td>A2</td><td>A3</td><td>A4</td><td>A5</td> <td>D1</td><td>D2</td><td>D3</td><td>D4</td><td>D5</td><td>D6</td> <td>1</td><td>0</td><td>2</td><td>M</td><td>1</td><td>H</td><td>1</td> <td>Stop</td> </tr> </table>	Address5					Data6					Option2			Mask1			Check1			Address5					Data6					Option2			Mask1			Check1			A1	A2	A3	A4	A5	D1	D2	D3	D4	D5	D6	1	0	2	M	1	H	1	Stop	A1	A2	A3	A4	A5	D1	D2	D3	D4	D5	D6	1	0	2	M	1	H	1	Stop
Address5					Data6					Option2			Mask1			Check1			Address5					Data6					Option2			Mask1			Check1																																										
A1	A2	A3	A4	A5	D1	D2	D3	D4	D5	D6	1	0	2	M	1	H	1	Stop	A1	A2	A3	A4	A5	D1	D2	D3	D4	D5	D6	1	0	2	M	1	H	1	Stop																																								
7	<table border="1"> <tr> <td colspan="12">Data Code 12bit</td> </tr> <tr> <td>D1</td><td>2</td><td>3</td><td>4</td><td>5</td><td>6</td><td>7</td><td>8</td><td>9</td><td>10</td><td>11</td><td>12</td> <td>Stop</td> </tr> </table>	Data Code 12bit												D1	2	3	4	5	6	7	8	9	10	11	12	Stop																																																			
Data Code 12bit																																																																													
D1	2	3	4	5	6	7	8	9	10	11	12	Stop																																																																	
8	<table border="1"> <tr> <td colspan="12">Data Code 12bit</td> </tr> <tr> <td>Leader</td><td>D1</td><td>2</td><td>3</td><td>4</td><td>5</td><td>6</td><td>7</td><td>8</td><td>9</td><td>10</td><td>11</td><td>12</td> <td>Stop</td> </tr> </table>	Data Code 12bit												Leader	D1	2	3	4	5	6	7	8	9	10	11	12	Stop																																																		
Data Code 12bit																																																																													
Leader	D1	2	3	4	5	6	7	8	9	10	11	12	Stop																																																																
9	<table border="1"> <tr> <td colspan="8">Custom Code 8bit</td> <td colspan="8">Data Code 8bit</td> </tr> <tr> <td>Leader</td><td>C1</td><td>C2</td><td>C3</td><td>C4</td><td>C5</td><td>C6</td><td>C7</td><td>C8</td> <td>Separator</td> <td>D1</td><td>D2</td><td>D3</td><td>D4</td><td>D5</td><td>D6</td><td>D7</td><td>D8</td> <td>Stop</td> </tr> </table>	Custom Code 8bit								Data Code 8bit								Leader	C1	C2	C3	C4	C5	C6	C7	C8	Separator	D1	D2	D3	D4	D5	D6	D7	D8	Stop																																									
Custom Code 8bit								Data Code 8bit																																																																					
Leader	C1	C2	C3	C4	C5	C6	C7	C8	Separator	D1	D2	D3	D4	D5	D6	D7	D8	Stop																																																											
10	<table border="1"> <tr> <td colspan="8">Custom Code 8bit</td> <td colspan="8">Custom Code 8bit</td> <td colspan="8">Data Code 8bit</td> <td colspan="8">Data Code 8bit</td> </tr> <tr> <td>Leader</td><td>C1</td><td>C2</td><td>C3</td><td>C4</td><td>C5</td><td>C6</td><td>C7</td><td>C8</td> <td>C1</td><td>C2</td><td>C3</td><td>C4</td><td>C5</td><td>C6</td><td>C7</td><td>C8</td> <td>D1</td><td>D2</td><td>D3</td><td>D4</td><td>D5</td><td>D6</td><td>D7</td><td>D8</td> <td>D1</td><td>D2</td><td>D3</td><td>D4</td><td>D5</td><td>D6</td><td>D7</td><td>D8</td> <td>Stop</td><td>Repeat</td> </tr> </table>	Custom Code 8bit								Custom Code 8bit								Data Code 8bit								Data Code 8bit								Leader	C1	C2	C3	C4	C5	C6	C7	C8	C1	C2	C3	C4	C5	C6	C7	C8	D1	D2	D3	D4	D5	D6	D7	D8	D1	D2	D3	D4	D5	D6	D7	D8	Stop	Repeat									
Custom Code 8bit								Custom Code 8bit								Data Code 8bit								Data Code 8bit																																																					
Leader	C1	C2	C3	C4	C5	C6	C7	C8	C1	C2	C3	C4	C5	C6	C7	C8	D1	D2	D3	D4	D5	D6	D7	D8	D1	D2	D3	D4	D5	D6	D7	D8	Stop	Repeat																																											
11	<table border="1"> <tr> <td colspan="4">Custom Code 8bit</td> <td colspan="4">Data Code 8bit</td> <td colspan="4">Custom Code 8bit</td> <td colspan="4">Data Code 8bit</td> </tr> <tr> <td>Leader</td><td>C1</td><td>C2</td><td>C3</td><td>C4</td><td>C5</td><td>C6</td><td>C7</td><td>C8</td> <td>D1</td><td>D2</td><td>D3</td><td>D4</td><td>D5</td><td>D6</td> <td>C1</td><td>C2</td><td>C3</td><td>C4</td><td>C5</td><td>C6</td><td>C7</td><td>C8</td> <td>D1</td><td>D2</td><td>D3</td><td>D4</td><td>D5</td><td>D6</td> <td>Stop</td> </tr> </table>	Custom Code 8bit				Data Code 8bit				Custom Code 8bit				Data Code 8bit				Leader	C1	C2	C3	C4	C5	C6	C7	C8	D1	D2	D3	D4	D5	D6	C1	C2	C3	C4	C5	C6	C7	C8	D1	D2	D3	D4	D5	D6	Stop																														
Custom Code 8bit				Data Code 8bit				Custom Code 8bit				Data Code 8bit																																																																	
Leader	C1	C2	C3	C4	C5	C6	C7	C8	D1	D2	D3	D4	D5	D6	C1	C2	C3	C4	C5	C6	C7	C8	D1	D2	D3	D4	D5	D6	Stop																																																
12	<table border="1"> <tr> <td colspan="5">Custom Code 5bit</td> <td colspan="5">Data Code 8bit</td> <td colspan="5">Custom Code 5bit</td> <td colspan="5">Data Code 8bit</td> </tr> <tr> <td>Leader</td><td>C1</td><td>C2</td><td>C3</td><td>C4</td><td>C5</td> <td>D1</td><td>D2</td><td>D3</td><td>D4</td><td>D5</td><td>D6</td> <td>C1</td><td>C2</td><td>C3</td><td>C4</td><td>C5</td> <td>D1</td><td>D2</td><td>D3</td><td>D4</td><td>D5</td><td>D6</td> <td>Stop</td> </tr> </table>	Custom Code 5bit					Data Code 8bit					Custom Code 5bit					Data Code 8bit					Leader	C1	C2	C3	C4	C5	D1	D2	D3	D4	D5	D6	C1	C2	C3	C4	C5	D1	D2	D3	D4	D5	D6	Stop																																
Custom Code 5bit					Data Code 8bit					Custom Code 5bit					Data Code 8bit																																																														
Leader	C1	C2	C3	C4	C5	D1	D2	D3	D4	D5	D6	C1	C2	C3	C4	C5	D1	D2	D3	D4	D5	D6	Stop																																																						
13	<table border="1"> <tr> <td colspan="8">Custom Code 8bit</td> <td colspan="8">Data Code 8bit</td> </tr> <tr> <td>C1</td><td>C2</td><td>C3</td><td>C4</td><td>C5</td><td>C6</td><td>C7</td><td>C8</td> <td>D1</td><td>D2</td><td>D3</td><td>D4</td><td>D5</td><td>D6</td><td>D7</td><td>D8</td> <td>Stop</td> </tr> </table>	Custom Code 8bit								Data Code 8bit								C1	C2	C3	C4	C5	C6	C7	C8	D1	D2	D3	D4	D5	D6	D7	D8	Stop																																											
Custom Code 8bit								Data Code 8bit																																																																					
C1	C2	C3	C4	C5	C6	C7	C8	D1	D2	D3	D4	D5	D6	D7	D8	Stop																																																													
14	<table border="1"> <tr> <td colspan="8">Custom Code 8bit</td> <td colspan="8">Custom Code 8bit</td> <td colspan="8">Data Code 8bit</td> <td colspan="8">Data Code 8bit</td> </tr> <tr> <td>Leader</td><td>C1</td><td>C2</td><td>C3</td><td>C4</td><td>C5</td><td>C6</td><td>C7</td><td>C8</td> <td>C1</td><td>C2</td><td>C3</td><td>C4</td><td>C5</td><td>C6</td><td>C7</td><td>C8</td> <td>D1</td><td>D2</td><td>D3</td><td>D4</td><td>D5</td><td>D6</td><td>D7</td><td>D8</td> <td>D1</td><td>D2</td><td>D3</td><td>D4</td><td>D5</td><td>D6</td><td>D7</td><td>D8</td> <td>Stop</td><td>Repeat</td> </tr> </table>	Custom Code 8bit								Custom Code 8bit								Data Code 8bit								Data Code 8bit								Leader	C1	C2	C3	C4	C5	C6	C7	C8	C1	C2	C3	C4	C5	C6	C7	C8	D1	D2	D3	D4	D5	D6	D7	D8	D1	D2	D3	D4	D5	D6	D7	D8	Stop	Repeat									
Custom Code 8bit								Custom Code 8bit								Data Code 8bit								Data Code 8bit																																																					
Leader	C1	C2	C3	C4	C5	C6	C7	C8	C1	C2	C3	C4	C5	C6	C7	C8	D1	D2	D3	D4	D5	D6	D7	D8	D1	D2	D3	D4	D5	D6	D7	D8	Stop	Repeat																																											

Note 1) Each wave form is available as the masked ROM option.



(3-2) The Number of Output Frame

The number of transmission signal frame generated by minimum key input time is available as the masked ROM option. It has from 1 frame to 8 frame.

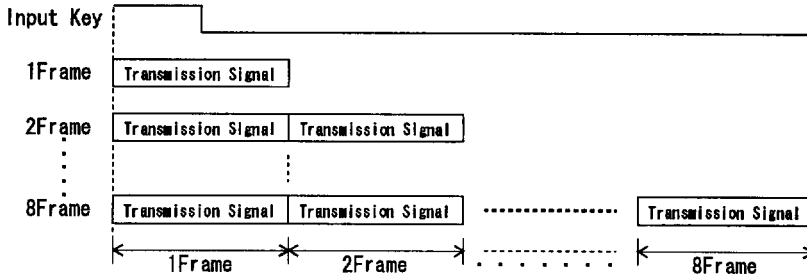

(4) Key Operation

(4-1) Standard Key Operation

The key board matrix correspond to the ROM code address is shown as follows:

Standard Key Matrix								
Key Scan	EC ₀	EC ₁	EC ₂	EC ₃	EC ₄	EC ₅	EC ₆	EC ₇
KS ₀	00 (KY1)	08 (KY9)	16 (KY17)	24 (KY25)	32 (KY33)	40 (KY41)	48 (KY49)	56 (KY57)
KS ₁	01 (KY2)	09 (KY10)	17 (KY18)	25 (KY26)	33 (KY34)	41 (KY42)	49 (KY50)	57 (KY58)
KS ₂	02 (KY3)	10 (KY11)	18 (KY19)	26 (KY27)	34 (KY35)	42 (KY43)	50 (KY51)	58 (KY59)
KS ₃	03 (KY4)	11 (KY12)	19 (KY20)	27 (KY28)	35 (KY36)	43 (KY44)	51 (KY52)	59 (KY60)
KS ₄	04 (KY5)	12 (KY13)	20 (KY21)	28 (KY29)	36 (KY37)	44 (KY45)	52 (KY53)	60 (KY61)
KS ₅	05 (KY6)	13 (KY14)	21 (KY22)	29 (KY30)	37 (KY38)	45 (KY46)	53 (KY54)	61 (KY62)
KS ₆	06 (KY7)	14 (KY15)	22 (KY23)	30 (KY31)	38 (KY39)	46 (KY47)	54 (KY55)	62 (KY63)
KS ₇	07 (KY8)	15 (KY16)	23 (KY24)	31 (KY32)	39 (KY40)	47 (KY48)	55 (KY56)	63 (KY64)

Note 2) The inside of parentheses means the key number.

Only for standard key operation, when the roll over input occurs, the transmission data in the data register is cleared by the roll over preventive circuit and the transmission is forbid.

(4-2) Extension Key Operation

The extension key is connected between the OPT terminal and the key scan output terminal KS₆ or KS₇, key board matrix correspond to ROM code address is shown as follows:

Key Scan	Normal KeyMatrix	Extension Key Matrix																	
		EC ₀	EC ₁	EC ₂	EC ₃	EC ₄	EC ₅	EC ₆	EC ₇	OPT									
KS ₀	Shown upper	Not Double Press Key																	
KS ₁																			
KS ₂																			
KS ₃																			
KS ₄		Not Double Press Key																	
KS ₅																			
KS ₆											40	41	42	43	44	45	46	47	KY65
KS ₇											48	49	4A	4B	4C	4D	4E	4F	KY66

The extension key is formed by the KY33 and the KY34, and it is generated the extension code by operating with the combination key.



The combination key corresponded to the extension key is as follows;

Double Space Key	Combination Key							
KY65	KY7	KY15	KY23	KY31	KY39	KY47	KY55	KY63
KY66	KY8	KY16	KY24	KY32	KY40	KY48	KY56	KY64

It is correspondence as this table, therefore any other combinations aren't transmitted, besides, only extension key KY65 or KY66 isn't transmitted. The extension key should be pushed with the combination key.

(4-3) Key Timing Prevented Of Two Key Roll Over

The timing of key scan is 0.21msec. The time to stop scanning is about 36msec. Besides, to prevent chattering of key ON, a data isn't read for 9msec after pressing a key. Therefore the key timing prevented of two key roll over is as follow;

- ① Pressing At The Same Time Within 36msec → Forbidding Transmission

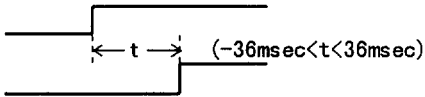

- ② Pressing Second Key after 36msec

→ After Transmitting First Key Data, Forbidding Transmission

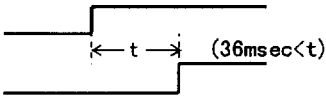

- ③ Taking Off Both Key Within 36msec

→ Forbidding Transmission

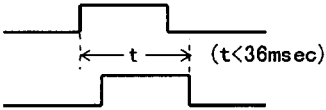

- ④ Taking Off The Other Key After 36msec

→ Transmitting Rest Key Data

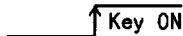
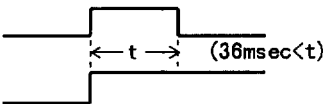

As this, provided an key is kept to press over 36msec, its code is transmitted once.

(4-4) Roll Over Timing Of Extension Key

When keys are pressed over two at the same time, transmission is usually forbid by the roll over preventive circuit. However, when the extension key is pressed, it is transmitted by operating with the combination key at input timing as follows;



① Extension Key Signal Transmission

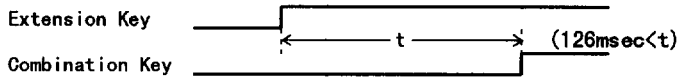

② Forbidding Extension Key Signal Transmission

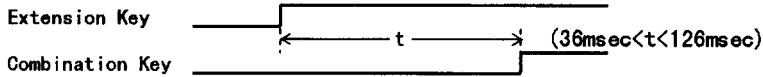

③ Forbidding Extension Key Signal Transmission

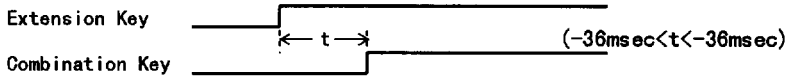

④ Forbidding Extension Key Signal Transmission

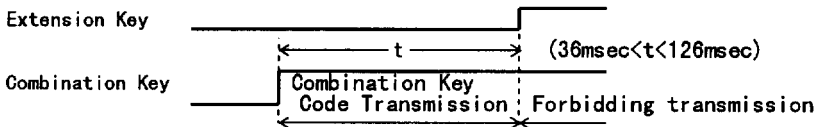

For the order of the priority of pressing key, the extension key can operate when only the combination key is pressed after 126msec at the time of pressing the extension key.

(5) Carrier Frequency Generating Circuit

Each other ceramic resonator corresponded to the carrier wave frequency is shown below.

For ROM option, the ceramic resonator should be specified.

	Seramics resonator f_{osc} (kHz)				
	393	440	455	480	455
Carrier Frequency f_{ca} (kHz)	32.8	36.7	37.9	40.0	56.9
Dividing Frequency Percentage	$f_{osc}/12$	$f_{osc}/12$	$f_{osc}/12$	$f_{osc}/12$	$f_{osc}/8$

The carrier frequency is output in 1/3 duty.

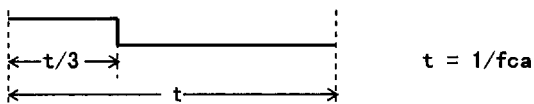

In case of using the ceramic resonator 455kHz and set the frequency dividing ratio to $f_{osc}/8$, the carrier frequency is 1/2 duty.



(6) Auto Clear Circuit

Connecting the capacitor between the \overline{AC} terminal and V_{SS} , auto clear function is executed at the time of power-on. After the V_{DD} terminal voltage is risen to 2.0V, it is required that the period (T_c) which the \overline{AC} terminal voltage (V_c) becomes $V_c > 0.3V_{DD}$ is $T_c > 0.1\text{msec}$. After auto clear function is executed, this circuit is kept the stand-by mode until a key is input.

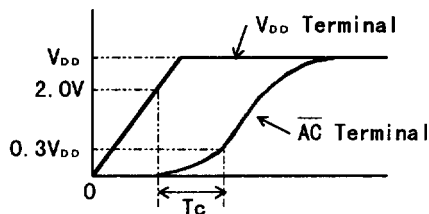
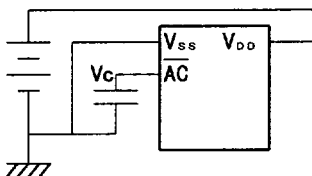

An external capacitance should be connected value more than 2nF.
Example expressions are shown below.

• For example ($V_{DD}=3.0\text{V}$ Operating)

V_{min} : Minimum Operating Voltage (2.0V)

V_c : \overline{AC} Terminal Voltage (0.3 V_{DD})

T_c : Time Until \overline{AC} Terminal is $V_c > 0.3\text{V}$ (more than 0.1ms)

R : Internal Pull-Up Resistance (80k Ω)

C : External Capacitance

$$V_c = V_{min} (1 - e^{-\frac{T_c}{CR}})$$

$$T_c = -CR \times \log\left(1 - \frac{V_c}{V_{min}}\right)$$

$$0.1(\text{ms}) \leq -C \times 80(\text{k}\Omega) \times \log\left(1 - \frac{0.9(\text{V})}{2.0(\text{V})}\right)$$

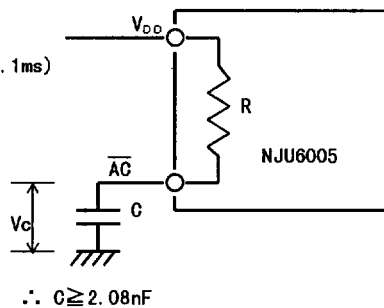

10

Therefore, in order to be executed auto clear function exactly, the capacitance more than this numerical value should be connected.

■ ABSOLUTE MAXIMUM RATINGS

(Ta=25°C)

PARAMETER	SYMBOL	RATINGS	UNIT
Supply Voltage	V _{DD}	-0.3 ~ +5.5	V
Input Voltage	V _{IN}	V _{SS} -0.3 ~ V _{DD} +0.3	V
Operating Temperature	Topr	- 25 ~ + 75	°C
Storage Temperature	Tstg	- 40 ~ + 125	°C

■ ELECTRICAL CHARACTERISTICS

 (V_{DD}=3.0V, Ta=25°C)

PARAMETER	SYMBOL	CONDITIONS	MIN.	TYP.	MAX.	UNIT	NOTE
Operating Voltage	V _{DD}	fosc=455kHz	2.0		3.6	V	
Operating Current	I _{DD}	fosc=455kHz			1.0	mA	
Stand-by Current	I _{ST}				1.0	μA	
"H" Input Voltage	V _{IH}	Each EC, OPT Terminal	0.7V _{DD}		V _{DD}	V	
"L" Input Voltage	V _{IL}	Each EC, OPT Terminal			0.3V _{DD}	V	
Oscillation Frequency	fosc	X _{IN} , X _{OUT} Terminal		393 440 455 480		kHz	3
Output Current(1)	I _{OL1}	V _{OL} =0.9V	0.3	0.8		mA	
	I _{OH1}	V _{OH} =2.0V					
Output Current(2)	I _{OL2}	V _{OL} =0.9V	1.0	4.0		mA	
Feedback Resistance	R _f	X _{IN} =V _{DD}		1		MΩ	
Pull-up Resistance	R _{1,1}	OPT Terminal		100		kΩ	
	R _{1,2}	Each EC Terminal		100			
	R _{1,3}	AC Terminal		80			
Pull-down Resistance	R _{1,4}	TEST Terminal		200		kΩ	

Note 3) The oscillation frequency is turned by depending the ceramic resonator.

The carrier frequency is the masked ROM option, therefore the ceramic resonator should be designated.



■ APPLICATION CIRCUIT

(1) Normal Key

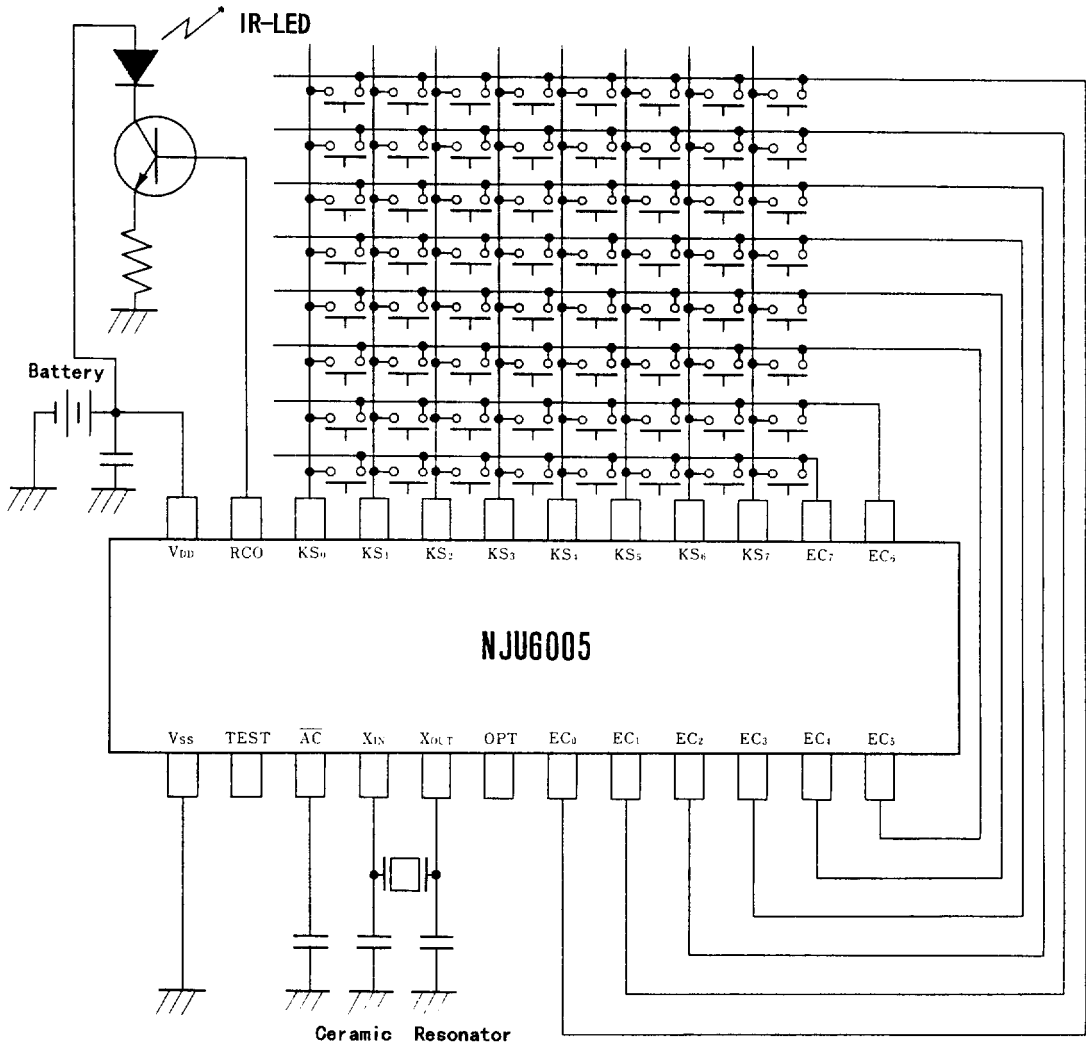

10



(2) Double Press Key

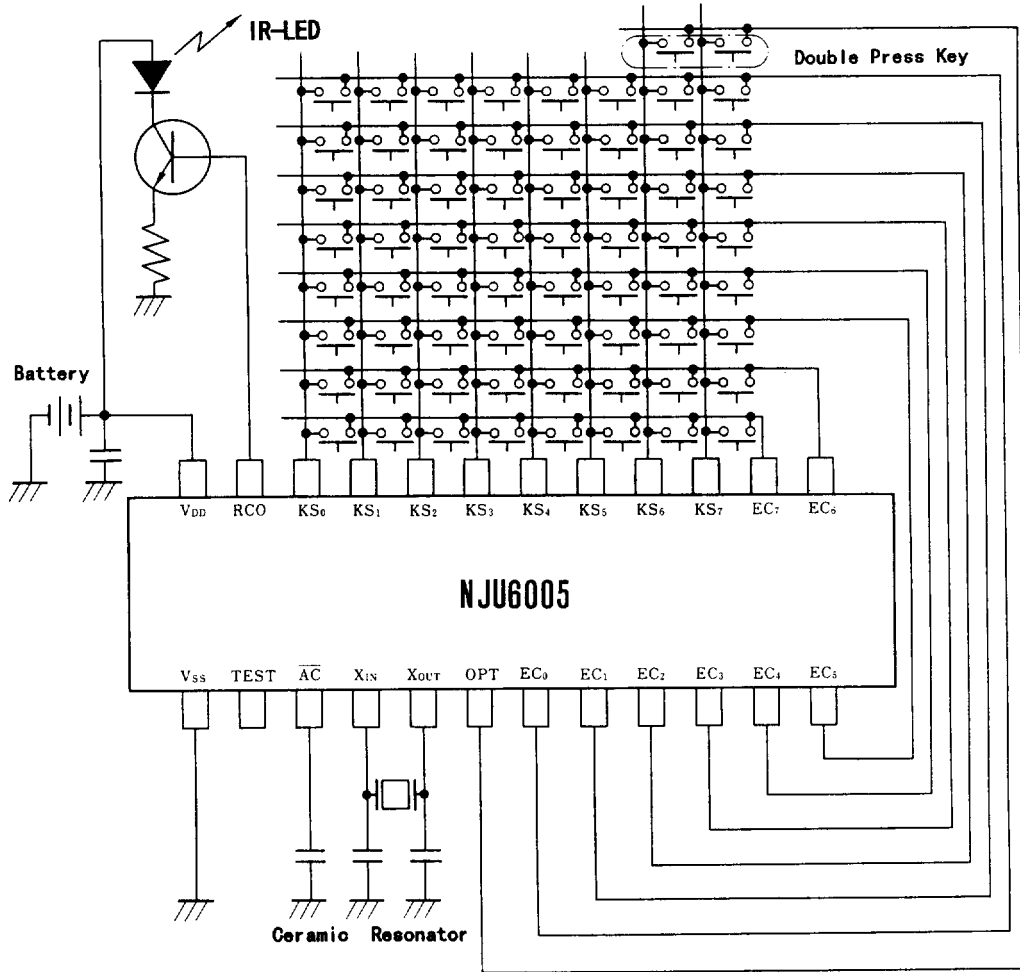

10