

FEATURES

32 Mb/s Data Transfer Rate Capability
Functionally Complete Read Channel Wideband AGC
Peak Hold Mode or Averaging
7th Order Bessel Filter
Programmable Cutoff Frequency
Programmable Equalization
Data Qualifier
Amplitude Qualification
Data Polarity Check
Data Synchronizer
Zero Phase Start-Up
DAC Controlled Center Frequency
DAC Controlled Window Center
1-7 ENDEC
Independent Early/Late Precompensation
Write Clock Synthesizer
6-Bit M and N Dividers
Servo Demodulator
A, B, C, D Sampling
Slew Rate Limiting or Peak Hold
Power Down Options
52-Pin PQFP Package
+5 Volt Supply

PRODUCT DESCRIPTION

The AD899 offers a functionally complete read channel operating at up to 32 Mb/s and is completely compatible with constant density recording. When it is connected to the output of the head amplifier, it performs the signal conditioning, data qualification, data synchronization and Encoding/Decoding task with a minimum of external components. To support constant density recording, a high performance frequency synthesizer and a programmable filter are also included, as is a servo demodulator to support embedded servo applications.

The AD899 is ideally suited for a wide variety of applications given its built-in flexibility. All major read channel characteristics are programmable on the AD899 through a standard serial port. The serial port controls the following critical characteristics: AGC setting, filter cutoff frequency and boost, data qualification amplitude threshold, data synchronizer center frequency, window center, write precompensation amount (Independent Early and Late), M and N divider ratios for the frequency synthesizer, as well as the power down options.

The AD899 will be available in a 52-pin quad flat pack package (PQFP) and is specified to operate over the commercial (0°C to +70°C) temperature range.

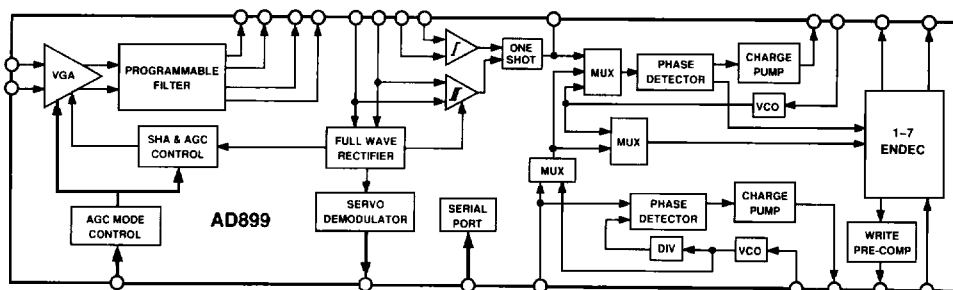
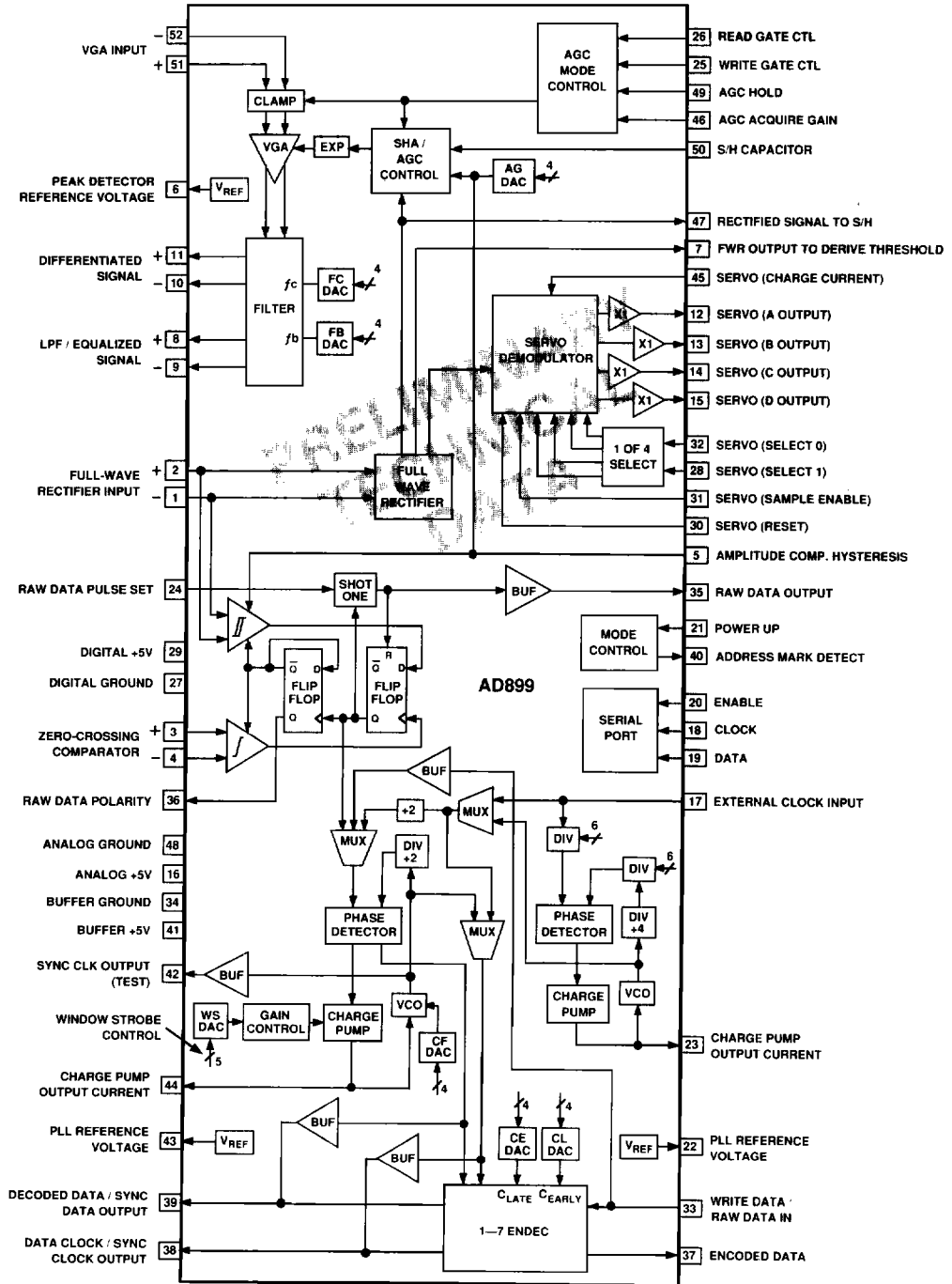

Figure 1. Simplified AD899 Block Diagram

This information applies to a product under development. Its characteristics and specifications are subject to change without notice. Analog Devices assumes no obligation regarding future manufacture unless otherwise agreed to in writing.

AD899

FUNCTIONAL BLOCK DIAGRAM



This information applies to a product under development. Its characteristics and specifications are subject to change without notice. Analog Devices assumes no obligation regarding future manufacture unless otherwise agreed to in writing.