

## MIL-STD-1553 DATA BUS SINGLE AND DUAL TRANSCEIVERS



BUS-63102



BUS-63105



BUS-63125

### DESCRIPTION

The BUS-63100 transceivers are complete transmitter and receiver pairs conforming fully to MIL-STD-1553A and 1553B. Features available with selected models of this high reliability series include: Smiths and Harris interface type choices, +12 V/+15 V power supply voltage range, variable threshold levels, and single (24-pin DDIP or square) and completely independent dual redundant (36-pin DDIP) packaging configurations. All models are also available in flat packs.

The receiver section of the BUS-63100 series accepts phase-modulated bipolar data from a MIL-STD-1553 Data Bus and produces TTL signal data at its outputs: RX Data Out and RX Data Out. These outputs represent positive and negative variations of the input data signals beyond an

internally fixed or externally set threshold level. An external STROBE input enables or disables the receiver outputs.

The transmitter section accepts bipolar TTL signal data at its TX Data and TX Data input lines and produces phase modulated bipolar data at the TX Data and TX Data outputs. The transmitters' output voltage level is typically 28 V<sub>pp</sub> to 30 V<sub>pp</sub>. An external input, INHIBIT, takes priority over the transmitter inputs and disables the transmitter when activated with a logic "1."

The small size and different model capabilities available with the BUS-63100 series simplify engineering design, making it an excellent choice for interfacing with any MIL-STD-1553 system.

### FEATURES

- **Conforms Fully to MIL-STD-1553A and 1553B**
- **Some Models Available to Military (DESC) Drawings**
- **Model Capabilities:**
  - **Single or Dual Redundant Packaging**
  - **-12 V/-15 V Power Supply Voltage Range Available**
  - **Harris or Smith's I/O Compatibility**
- **Small Size:**
  - **Single – 24-Pin DDIP or Square**
  - **Dual – 36-Pin DDIP Flat Packs**
- **Low Power**
- **High Reliability – LSI**

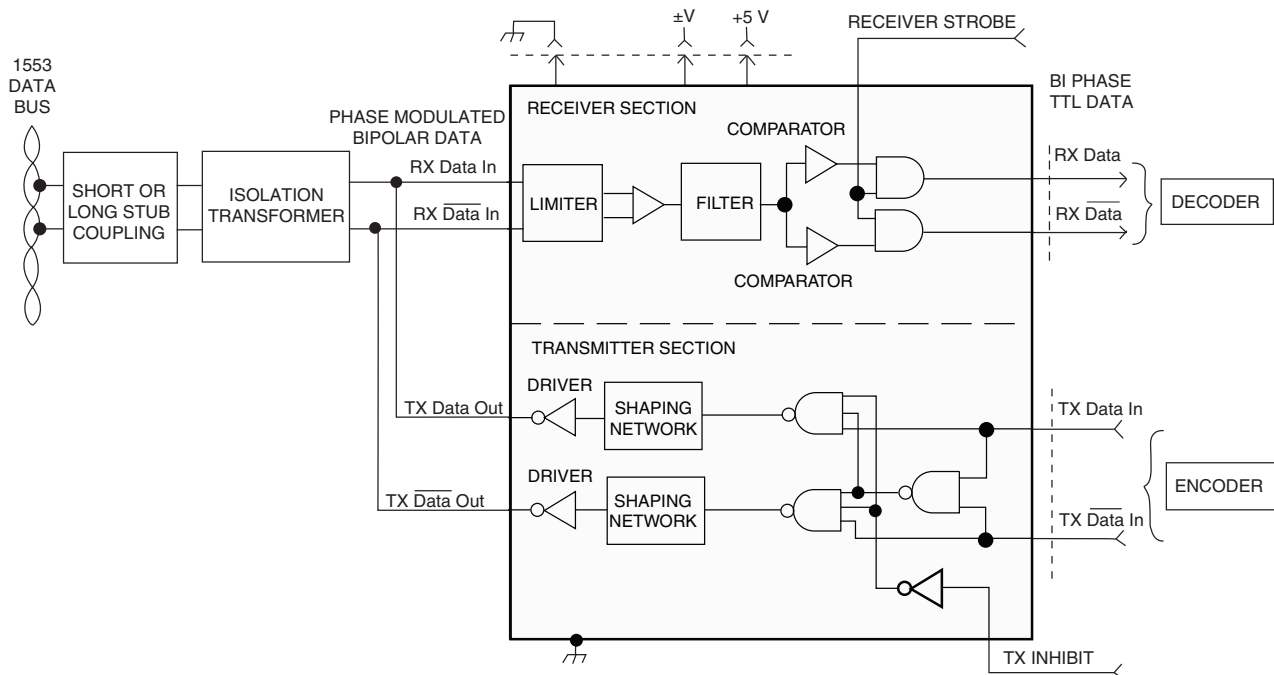

FIGURE 1. BUS-63100 BLOCK DIAGRAM

## GENERAL

The BUS-63100 Series offers complete transmitter and receiver pairs packaged in either single or dual redundant form which are designed for use in any MIL-STD-1553 application.

Figure 1 shows a BUS-63100 Series transceiver connected to a MIL-STD 1553 Data Bus. Once transformer isolated, coupling to a MIL-STD-1553 Data Bus can be either short stub (direct) or long (transformer). Figure 2 shows the different configurations and lists the recommended DDC transformer bus product for use with each model.

## TRANSCEIVER CAPABILITIES

DDC's BUS-63100 Series of transceivers offer a wide range of capabilities (on selected models), which include power supply voltage levels, packaging configurations, Smiths or Harris type encode/decoder direct compatibility, and internal (pre-set) and/or external (adjustable) threshold levels. The capabilities of the different models are described in the paragraphs which follow and are summarized in TABLE 1.

## POWER SUPPLY VOLTAGES

Power supply voltage requirements on the BUS-63102 and BUS-63104 are met over a range from  $\pm 12$  V to  $\pm 15$  V. All models operate with either -12 V or -15 V supplies. All models require a + 5 V supply. Refer to TABLE 1.

## PACKAGING CONFIGURATIONS

Single transceivers, BUS-63102 and BUS-63104 are packaged in 24 pin square packages, all other single transceivers are packaged in 24 pin DDIP. BUS-63123 is packaged in a 36-pin Flat Pack. Other Dual Transceivers are available in 36-pin DDIPD or Flat Pack.

## ENCODER/DECODER COMPATIBILITY

BUS-63105, BUS-63107, BUS-63123, BUS-63125 and BUS-63127 are directly compatible with Harris 15530 type Encoder/Decoders. All other transceivers are directly compatible to Smiths type. Transceivers which are directly comparable with one type can be converted for use with the other by simply switching the output lines,  $\overline{\text{RX}}$  Data and RX Data, and inverting their signals by means of external inverting gates.

## WAVEFORMS

All transceivers conform fully to MIL-STD-1553 requirements. Additionally, BUS-63102 conforms to MACAIR standards, producing sinusoidal waveforms at 1 MHz.

## THRESHOLD LEVELS

All models offer internal (factory preset) threshold levels. Additionally, BUS-63102 and BUS-63104 offer externally set threshold levels. These external threshold levels are adjustable from 0 V to 2 V, with the use of two external 10 KOhm potentiometers; see FIGURE 5.

TX Data In	TX $\overline{\text{Data}}$ In	TX INHIBIT	DRIVER OUTPUT <sup>(2)</sup>
X <sup>(1)</sup>	X	H	OFF <sup>(3)</sup>
0	0	X	OFF
0	1	L	ON
1	0	L	ON
1	1	X	OFF

NOTES:

(1) X = Don't Care

(2) DRIVER OUT = TX Data Out and TX  $\overline{\text{Data}}$  Out.

(3) DRIVER OUTPUT terminals are in the high impedance mode during OFF time, independent of INHIBIT status.

	$\pm 12$ VDC TO $\pm 15$ VDC	-12 VDC	-15 VDC	24 PIN DDIP	24 PIN SQUARE	36 PIN DDIP	I/O COMPATIBILITY		THRESHOLD		MACAIR	MIL-STD-1553	FLATPACK MODEL NO.
							SMITHS	HARRIS	INT	EXT			
<b>Single</b>													
BUS-63102	•				•		•		•	•	•	•	<b>Single</b> BUS-63112
BUS-63104	•				•		•		•	•		•	BUS-63114
BUS-63105			•	•				•	•			•	BUS-63106
BUS-63107		•		•				•	•			•	BUS-63108
BUS-63115			•	•			•		•			•	BUS-63116
BUS-63117		•		•			•		•			•	BUS-63118
<b>Dual</b>													
BUS-63125			•			•		•	•			•	<b>Dual</b> BUS-63123 BUS-63126
BUS-63127		•				•		•	•			•	BUS-63128
BUS-63135			•			•	•		•			•	BUS-63136
BUS-63137		•				•	•		•			•	BUS-63138

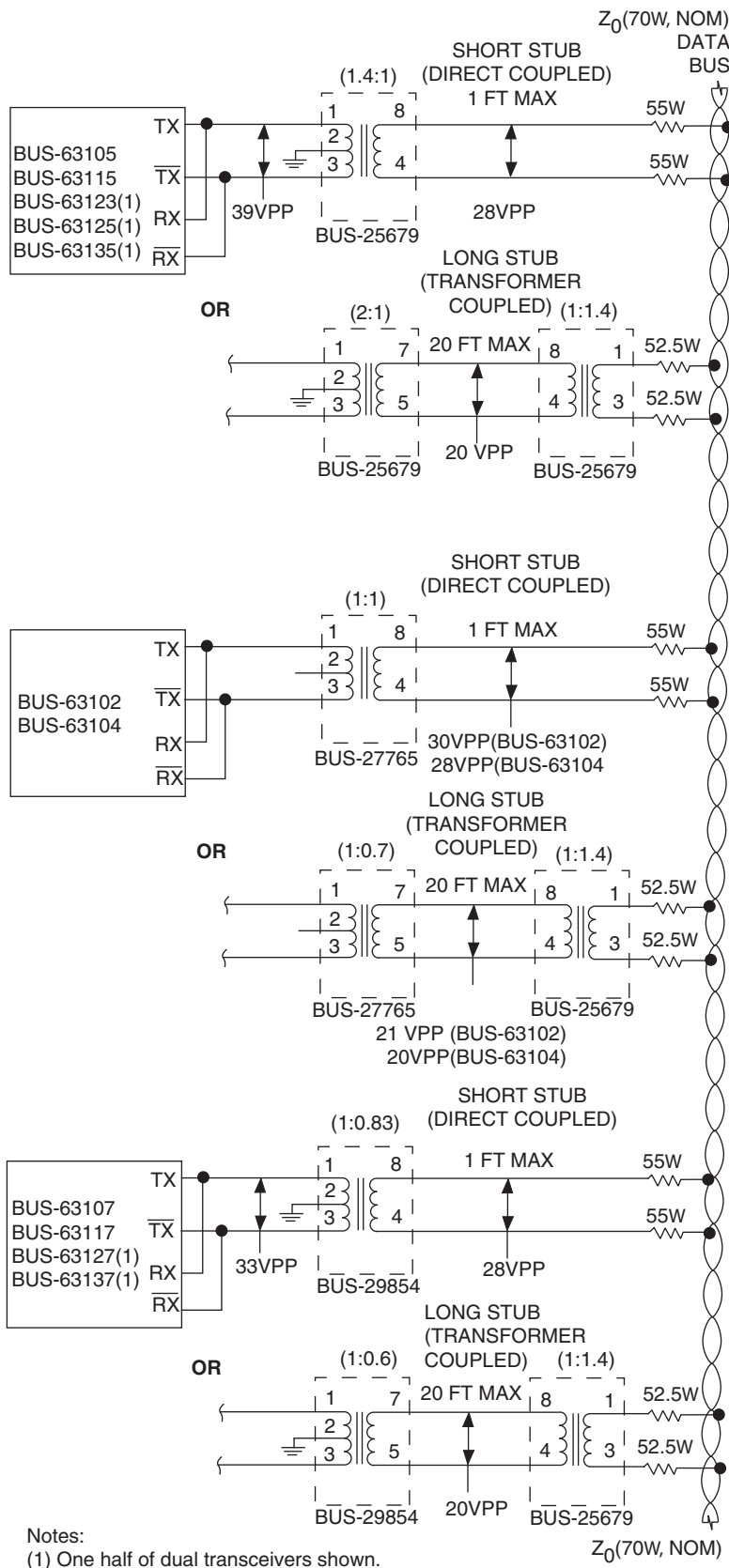

- Notes:
- (1) One half of dual transceivers shown.
  - (2) Bus must be terminated with its characteristic impedance at both ends.
  - (3) Only one connection can be made from the Transceiver to the MIL-STD Data Bus, either long stub or short but not both.

**FIGURE 2. BUS COUPLING CONFIGURATIONS**

**TABLE 3. BUS-63100 SERIES SPECIFICATIONS**

<b>TRANSCEIVER NUMBER</b>	<b>BUS-63102<sup>(1)</sup></b>	<b>BUS-63104</b>	<b>BUS-63105<sup>†</sup></b>	<b>BUS-63104</b>
<b>CHANNELS</b>	<b>BUS-63112</b>	<b>BUS-63114</b>	<b>BUS-63112</b>	<b>BUS-63114</b>
<b>POWER SUPPLIES</b>	Single ±12 VDC to ±15 VDC	Single ±12 VDC to ±15 VDC	Single -15 VDC	Single -15 VDC
<b>ENCODER/DECODER INTERFACE TYPE</b>	Smiths	Smiths	Harris	Smiths
<b>MATCHING TRANSFORMER MODEL</b>	<b>BUS-27765</b>	<b>BUS-27765</b>	<b>BUS-25679</b>	<b>BUS-25679</b>
<b>RECEIVER</b>				
Strobe	1 'LS Load	*	1 TTL	*
Input Level	40 Vpk-pk, Diff. max	*	*	*
Threshold Level (Internal)(2)(3)	0.5 Vpk-pk min, 1.0 Vpk-pk max	*	0.56 Vpk-pk min, 1.0 Vpk-pk max	*
CMRR	40 db, min	*	*	*
Input Resistance-Diff.	7 kOhm, min	*	*	*
Input Capacitance-Diff.	5 pf, max	*	*	*
Output Fan Out	10 TTL Loads	*	*	*
<b>TRANSMITTER</b>				
TX Inhibit	1 'LS Load	*	1 TTL	*
Input Level	1 'LS Load	*	1 TTL	*
Output Level(Direct Coupled) <sup>(4)</sup>	29 Vpk-pk, nom across 140 Ohm load	*	*	*
Rise/Fall Time	280 ns, typ	150 ns, typ	125 ns, typ	*
Output Noise	10 mVpk-pk, Diff. max	*	*	*
Output Offset Voltage	±90 mVpk-pk, max across 35 Ohm load	*	*	*
Output Impedance-Non-Transmitting				
Output Resistance- Diff.	10 kOhm, min	*	*	*
Output Capacitance-Diff.	5 pF, max	*	*	*
<b>LOGIC</b>				
TTL/CMOS Compatible				
All Inputs	2' LS Loads, max	*	1 TTL	*
All Outputs	10 TTL Loads, max	*	*	*
<b>POWER SUPPLY REQUIREMENTS</b>				
	+5 VDC ±10%	+12 VDC to +15 VDC ±5%	-12 VDC to -15 VDC ±5%	+5 VDC ±10% -15 VDC ±5%
Non-Transmitting-(typ/max)	30/45 mA	24/30 mA	51/65 mA	30/45 mA 20/30 mA
Transmitting-50% duty cycle (typ/max)	30/45 mA	85/114 mA	118/135 mA	30/45 mA 95/130 mA
Transmitting-100% duty cycle (typ/max)	30/45 mA	140/180 mA	175/195 mA	30/45 mA 170/225 mA
<b>THERMAL</b>				
Operating Junction Temperature	-55°C to +160°C	*	*	*
Operating Case Temperature	-55°C to +125°C	*	*	*
Storage Temperature	-65°C to +150°C	*	*	*
Thermal Impedance				
Junction to Case	40°C/W (Hottest Die)	*	7.0°C/W	*
Case to Air (typ)	21°C/W (24 Pin Square)	*	30°C/W (24 Pin DDIP)	*
<b>POWER DISSIPATION</b>				
Single Channel Transmitting	12 V Supply	15 V Supply	15 V Supply	*
Non-Transmitting-(typ/max)	1.05/1.37 W	1.28/1.58 W	0.45/0.68 W	*
Transmitting-50% duty cycle (typ/max)	1.86/2.49 W	2.47/3.24 W	0.85/1.45 W	*
Transmitting-100% duty cycle (typ/max)	2.48/3.28 W	3.43/4.40 W	1.30/2.23 W	*
<b>POWER DISSIPATION</b>				
Hottest Die(5)	12 V Supply	15 V Supply	15 V Supply	*
Non-Transmitting-(typ/max)	0.0 W	0.0 W	0.45/0.68 W	*
Transmitting-50% duty cycle (typ/max)	0.12/0.15 W	0.15/0.18 W	0.85/1.45 W	*
Transmitting-100% duty cycle (typ/max)	0.24/0.29W	0.30/0.36 W	1.30/2.23 W	*
<b>MECHANICAL</b>				
Package Style	24 Pin Square	*	24 Pin DDIP	*
Dimensions	1.258" x 1.258" x 0.175"	*	1.400" x 0.805" x 0.200"	*
	31.95 mm x 31.95 mm x 4.45 x mm	*	35.56 mm x 20.32 mm x 5.08 x mm	*
Package Style	24 Pin Square Flat Pack	*	24 Pin Square Flat Pack	*
Dimensions	1.255" x 1.255" x 0.160"	*	1.275" x 0.775" x 0.175"	*
	31.88 mm x 31.88 mm x 4.06 x mm	*	32.36 mm x 19.69 mm x 4.45 x mm	*
Weight	0.6 oz	*	0.6 oz	*
	17 (g)	*	17 (g)	*

<b>BUS-63107</b>	<b>BUS-63117</b>
<b>BUS-63108</b>	<b>BUS-63118</b>
Single	Single
-12 VDC	-12 VDC
Harris	Smiths
<b>BUS-29854</b>	<b>BUS-29854</b>
*	*
*	*
*	*
*	*
*	*
*	*
*	*
115 ns, typ	*
*	*
*	*
*	*
*	*
*	*
*	*
+5 VDC ±10%	-12 VDC ±5%
30/45 mA	20/30 mA
30/45 mA	115/155 mA
30/45 mA	210/275 mA
*	*
*	*
*	*
30°C/W (24 Pin DDIP)	*
12 V Supply	*
0.39/0.59 W	*
0.81/1.36 W	*
1.30/2.16 W	*
12 V Supply	*
0.39/0.59 W	*
0.81/1.36 W	*
1.30/2.16 W	*
*	*
*	*
*	*
*	*
*	*
*	*
*	*
*	*

**NOTES for TABLE 3.**

- (1) On BUS-63102, filtering eliminates harmonics above 1 MHz. Differential group delay is ± 35 ns (10 kHz-2 MHz).
- (2) The Threshold Level, as referred to in this specification, is meant to be the maximum peak-to-peak voltage (measured on the Data Bus) that can be applied to the receivers' input without causing the output to change from the OFF state.
- (3) On BUS-63102 and BUS-63104, external threshold levels are adjustable from 0V to 2V, with two external 10K Ohm potentiometers. Connect one pot between pin 5 and GND and the other between pin 12 and GND.
- (4) On BUS-63102, Output Level (direct coupled) is 30 V pk-pk.
- (5) On BUS-63102 and BUS-63104, Hottest Die are defined as the driver transistors.
  - \* Same as value to the left.
  - † BUS-63105 available as Military (DESC) drawing 5962-86049-02ZC
  - †† BUS-63125 and BUS-63126 are available as Military (DESC) drawing 5962-87579.

**TABLE 3. BUS-63100 SERIES SPECIFICATIONS (CONTINUED)**

TABLE 3. BUS-63100 SERIES SPECIFICATIONS (CONTINUED)						
<b>TRANSCEIVER NUMBER</b>	<b>BUS-63123 ††</b> <b>BUS-63125 ††</b> <b>BUS-63126 ††</b>		<b>BUS-63135</b> <b>BUS-63136</b>		<b>BUS-63127</b> <b>BUS-63128</b>	
<b>CHANNELS</b> <b>POWER SUPPLIES</b> <b>ENCODER/DECODER INTERFACE TYPE</b> <b>MATCHING TRANSFORMER MODEL</b>	Dual -15 VDC Harris <b>BUS-25679</b>		Dual -15 VDC Smiths BUS-25679		Dual -12 VDC Harris BUS-29854	
<b>RECEIVER</b> Strobe Input Level Threshold Level (Internal)(2)(3) CMRR Input Resistance-Diff. Input Capacitance-Diff. Output Fan Out	1 'LS * * * * * *		* * * * * *		* * * * * *	
<b>TRANSMITTER</b> TX Inhibit Input Level Output Level(Direct Coupled) <sup>(4)</sup>  Rise/Fall Time Output Noise Output Offset Voltage  Output Impedance-Non-Transmitting Output Resistance- Diff. Output Capacitance-Diff.	1 'LS 1 'LS * * 150 ns, typ * * *  * * *		* * * * * * *  * * *		* * * * * * *  * * *	
<b>LOGIC</b> TTL/CMOS Compatible All Inputs All Outputs	2 'LS *		* *		* *	
<b>POWER SUPPLY REQUIREMENTS</b>	(Total Hybrid)		(Total Hybrid)		(Total Hybrid)	
	+5 VDC ±10%	-15 VDC ±5%	+5 VDC ±10%	-15 VDC ±5%	+5 VDC ±10%	-12 VDC ±5%
Non-Transmitting-(typ/max)	60/90 mA	40/60 mA	60/90 mA	40/60 mA	60/90 mA	40/60 mA
Transmitting-50% duty cycle (typ/max)	60/90 mA	115/160 mA	60/90 mA	115/160 mA	60/90 mA	135/185 mA
Transmitting-100% duty cycle (typ/max)	60/90 mA	190/255 mA	60/90 mA	190/255 mA	60/90 mA	230/305 mA
<b>THERMAL</b> Operating Junction Temperature Operating Case Temperature Storage Temperature Thermal Impedance Junction to Case Case to Air (typ)	* * *  7.0°C/W 20°C/W (36 Pin DDIP)		* * *  * *		* * *  * *	
<b>POWER DISSIPATION</b> Single Channel Transmitting	(Total Hybrid, One Channel Transmitting)		(Total Hybrid, One Channel Transmitting)		(Total Hybrid, One Channel Transmitting)	
Non-Transmitting-(typ/max)	0.90/1.35 W		0.90/1.35 W		0.78/1.18 W	
Transmitting-50% duty cycle (typ/max)	1.30/2.13 W		1.30/2.13 W		1.20/1.95 W	
Transmitting-100% duty cycle (typ/max)	1.75/2.91 W		1.75/2.91 W		1.69/2.75 W	
<b>POWER DISSIPATION</b> Hottest Die(5)	(Each Channel)		(Each Channel)		(Each Channel)	
Non-Transmitting-(typ/max)	0.45/0.68 W		0.45/0.68 W		0.39/0.59 W	
Transmitting-50% duty cycle (typ/max)	0.85/1.45 W		0.85/1.45 W		0.81/1.36 W	
Transmitting-100% duty cycle (typ/max)	1.30/2.23 W		1.30/2.23 W		1.30/2.16 W	
<b>MECHANICAL</b> Package Style Dimensions  Package Style Dimensions  Weight	36 Pin DDIP 1.895" x 0.775" x 0.210" 48.13 mm x19.69 mm x 5.33 mm  36 Pin Flat Pack 1.905" x 0.785" x 0.165" 48.39 mm x 19.94 mm x 4.19 mm 0.6 oz 17 (g)		* * * * * * *		* * * * * * *	

<b>BUS-63137</b>	
<b>BUS-63138</b>	
Dual -12 VDC Smiths BUS-29854	
* * * * * * *	
* * * * * * * *  * *	
* *	
(Total Hybrid)	
+5 VDC ±10%	-12 VDC ±5%
60/90 mA	40/60 mA
60/90 mA	135/185 mA
60/90 mA	230/305 mA
* * *  * *	
(Total Hybrid, One Channel Transmitting)	
0.78/1.18 W 1.20/1.95 W 1.69/2.75 W	
(Each Channel)	
0.39/0.59 W 0.81/1.36 W 1.30/2.16 W	
* * * * * * * *	

**NOTES for TABLE 3.**

- (1) On BUS-63102, filtering eliminates harmonics above 1 MHz. Differential group delay is ± 35 ns (10 kHz-2 MHz).
- (2) The Threshold Level, as referred to in this specification, is meant to be the maximum peak-to-peak voltage (measured on the Data Bus) that can be applied to the receivers' input without causing the output to change from the OFF state.
- (3) On BUS-63102 and BUS-63104, external threshold levels are adjustable from 0V to 2V, with two external 10K Ohm potentiometers. Connect one pot between pin 5 and GND and the other between pin 12 and GND.
- (4) On BUS-63102, Output Level (direct coupled) is 30 V pk-pk.
- (5) On BUS-63102 and BUS-63104, Hottest Die are defined as the driver transistors.
  - \* Same as value to the left.
  - † BUS-63105 available as Military (DESC) drawing 5962-86049-02ZC
  - †† BUS-63123, BUS-63125 and BUS-63126 are available as Military (DESC) drawing 5962-87579.

## RECEIVER OPERATING MODE

The receiver section accepts data from a MIL-STD-1553 Data Bus when properly coupled through a transformer in either the long stub or short stub configuration. The data is converted to bi-phase TTL and provided to the RX Data and RX Data output terminals for decoding. Applying a logic "1" to the STROBE input enables data to pass through to the receiver output(output enabled). Applying a logic "0" to the STROBE input turns the receiver output OFF (output disabled).

On BUS-63102, BUS-63104, BUS-63115, BUS-63117 and BUS-63137 receiver outputs are both at a logic "1" when they are either strobed off, or no signal is being received. This makes these models directly compatible with the Smiths type encoder/decoder. Typical operating waveforms are shown in FIGURE 3.

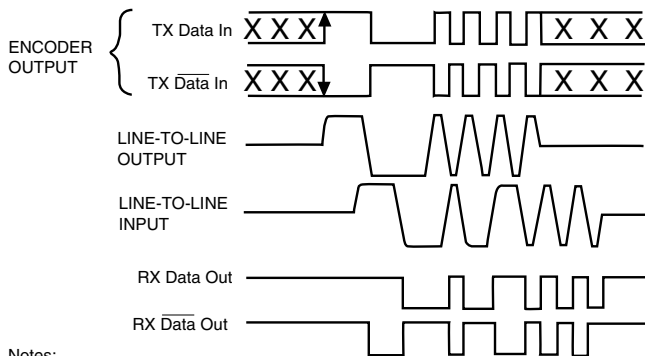

- Notes:
- (1) TX Data In and RX Data Out are TTL signals.
  - (2) TX Data In inputs must be at opposite logic levels during transmission, and at the same logic level when not transmitting.
  - (3) LINE-TO-LINE output voltage is measured between TX Data Out and TX Data Out.
  - (4) LINE-TO-LINE output voltage for BUS-63102 are sinusoidal waveforms for 1 MHz operating frequency.
  - (5) LINE-TO-LINE input voltage is measured on the Data Bus.

**FIGURE 3. TYPICAL OPERATING WAVEFORMS FOR SMITHS-COMPATIBLE TRANSCEIVER**

On all other models, BUS-63107, BUS-63123, BUS-63125 and BUS-63127, receiver outputs are both at a logic "0" when they are either strobed off, or no signal is being received. This makes these models directly compatible with the Harris type encoder/decoder. Typical operating waveforms are shown in FIGURE 4.

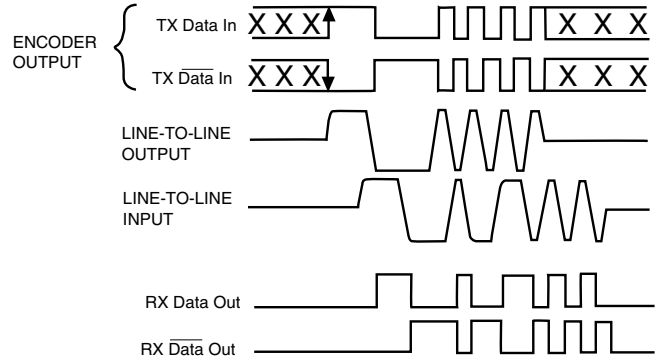

- Notes:
- (1) TX Data In and RX Data Out are TTL signals.
  - (2) TX Data In inputs must be at opposite logic levels during transmission, and at the same logic level when not transmitting.
  - (3) LINE-TO-LINE output voltage is measured between TX Data Out and TX Data Out.
  - (4) LINE-TO-LINE input voltage is measured on the Data Bus.

**FIGURE 4. TYPICAL OPERATING WAVEFORMS FOR HARRIS-COMPATIBLE TRANSCEIVER**

# 24 PIN SQUARE AND 24 PIN SQUARE FLAT PACK TRANSCEIVERS

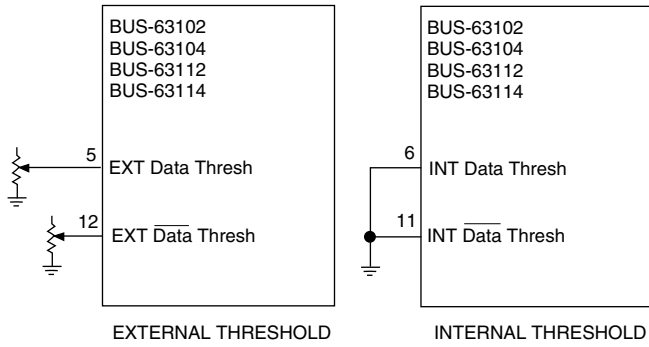
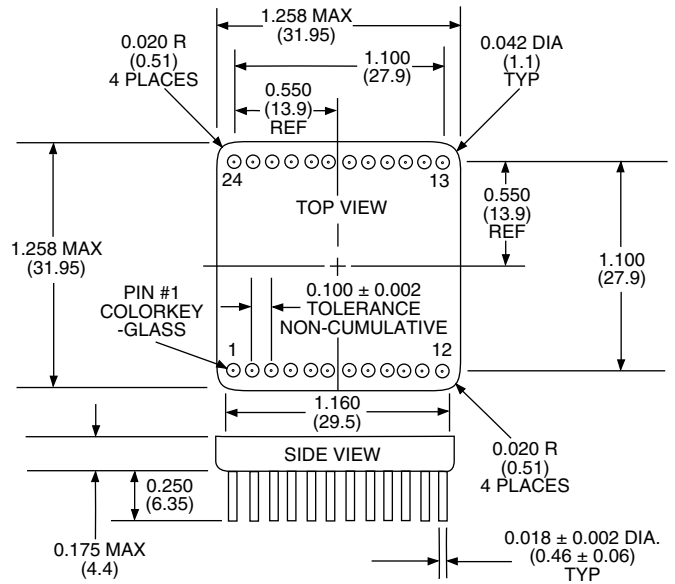

**FIGURE 5. THRESHOLD CONNECTIONS**

PIN	FUNCTION
1	TX Data Out
2	TX Data Out
3	GND
4	+12 VDC to +15 VDC
5	EXT Data Thresh
6	INT Data Thresh
7	RX Data Out
8	Strobe
9	GND
10	RX Data Out
11	INT Data Thresh
12	EXT Data Thresh
13	+12 VDC to +15 VDC
14	NC
15	RX Data In
16	RX Data In
17	GND
18	GND (case)
19	-12 VDC to -15 VDC
20	+ 5 VDC
21	TX Inhibit
22	TX Data In
23	TX Data In
24	-12 VDC to -15 VDC

**NOTE:**  
 For internal threshold levels, ground pins 6 and 11.  
 For external threshold, connect two 10K Ohm pots (one between pin 5 and GND, and the other between pin 12 and GND). See FIGURE 5.

**TABLE 4. BUS-63102, BUS63104, 24-PIN SQUARE AND BUS-63112, BUS63114, 24-PIN FLAT PACK PIN CONNECTIONS**



**FIGURE 6. BUS-63102 AND BUS-63104 MECHANICAL OUTLINE 24-PIN SQUARE PACKAGE**

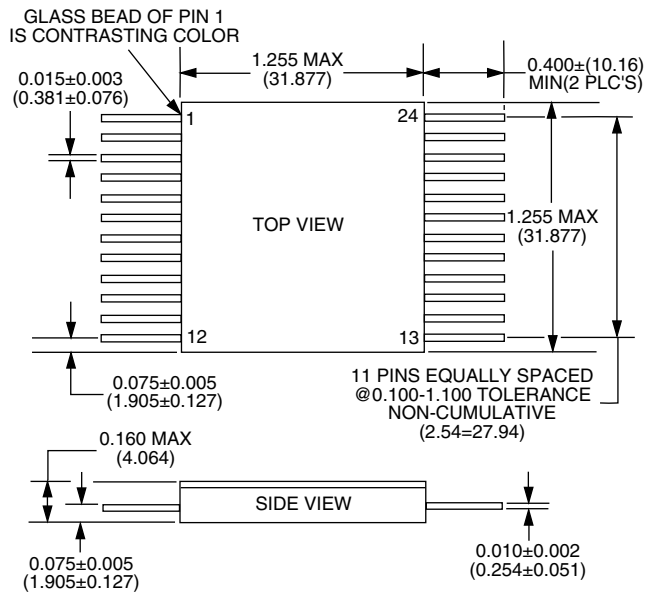
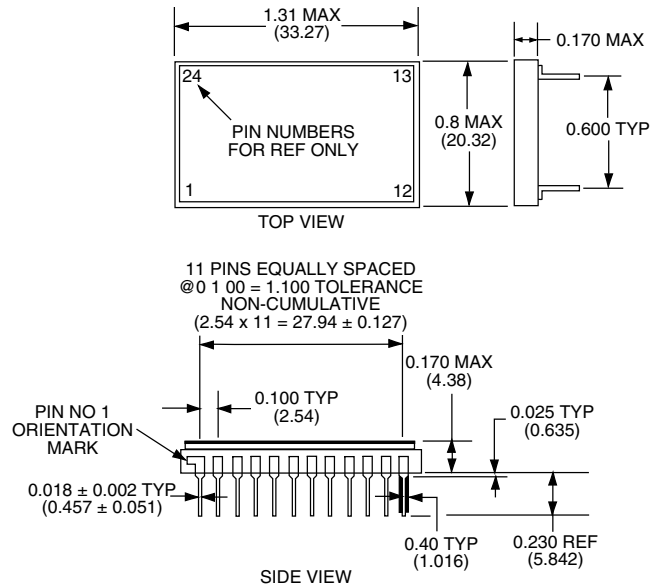

**FIGURE 7. BUS-63112 AND BUS-63114 MECHANICAL OUTLINE 24-PIN SQUARE PACKAGE**

# 24 PIN DDIP AND 24 PIN FLAT PACK TRANSCEIVERS

PIN	FUNCTION
1	TX Data Out
2	TX Data Out
3	GND
4	NC
5	NC
6	NC
7	RX Data Out
8	Strobe
9	GND
10	RX Data Out
11	NC
12	NC
13	NC
14	NC
15	RX Data In
16	RX Data In
17	NC
18	GND
19	-12 VDC or -15 VDC
20	+ 5 VDC
21	TX Inhibit
22	TX Data In
23	TX Data In
24	NC

**TABLE 5. BUS-63105, BUS63107, BUS-63115, BUS-63117, 24 PIN DDIP AND BUS-63106, BUS-63108, BUS-63116, BUS63118, 24 PIN FLAT PACK PIN CONNECTIONS**



**FIGURE 8. BUS-63105, BUS-63107, BUS-63115, AND BUS-63117 MECHANICAL OUTLINE 24-PIN SQUARE DDIP**

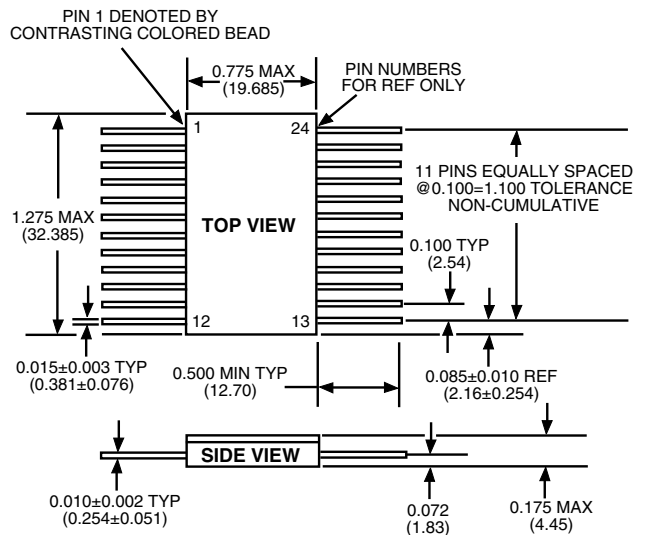

**FIGURE 9. BUS-63106, BUS-63108, BUS-63116, AND BUS-63118 MECHANICAL OUTLINE 24-PIN FLAT PACK**

# 36 PIN DDIP AND 36 PIN FLAT PACK TRANSCEIVERS

PIN	FUNCTION	
1	TX Data Out	*
2	TX $\overline{\text{Data}}$ Out	*
3	GND	*
4	NC	*
5	RX Data Out	*
6	Strobe	*
7	GND	*
8	RX $\overline{\text{Data}}$ Out	*
9	GND (case)	*
10	TX Data Out	**
11	TX $\overline{\text{Data}}$ Out	**
12	GND	**
13	NC	*
14	RX Data Out	**
15	Strobe	**
16	Gnd	**
17	RX $\overline{\text{Data}}$ Out	**
18	NC	*
19	NC	*
20	RX Data In	**
21	RX $\overline{\text{Data}}$ In	**
22	GND	**
23	-12 VDC or -15 VDC	**
24	+5 VDC	**
25	Inhibit	**
26	TX Data In	**
27	TX $\overline{\text{Data}}$ In	**
28	NC	*
29	RX Data In	*
30	RX $\overline{\text{Data}}$ In	*
31	GND	*
32	-12 VDC or -15 VDC	*
33	+5 VDC	*
34	Inhibit	*
35	TX Data In	*
36	TX $\overline{\text{Data}}$ In	*

**NOTES:**

- (1) -12 VDC for BUS-63127, BUS-63128, BUS-63137, and BUS-63138.
- (2) -15 VDC for BUS-63125, BUS-63126, BUS-63135, and BUS-63136

- \* Channel One
- \*\* Channel Two

**TABLE 6. BUS-63123, BUS-63125, BUS63127, BUS-63135, BUS-63137, 36-PIN DDIP AND BUS-63126, BUS-63128, BUS-63136, BUS63138, 36-PIN FLAT PACK PIN CONNECTIONS**

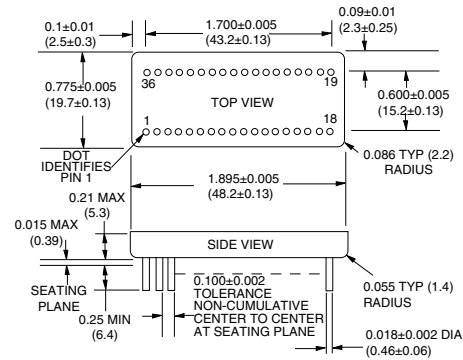

**FIGURE 10. BUS-63125, BUS-63127, BUS-63135, AND BUS-63137 MECHANICAL OUTLINE 36-PIN DDIP**

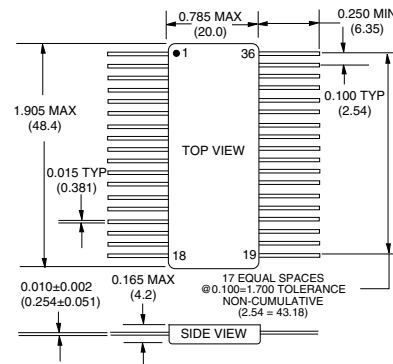

**FIGURE 11. BUS-63126, BUS-63128, BUS-63136, AND BUS-63138 MECHANICAL OUTLINE 36-PIN FLAT PACK**

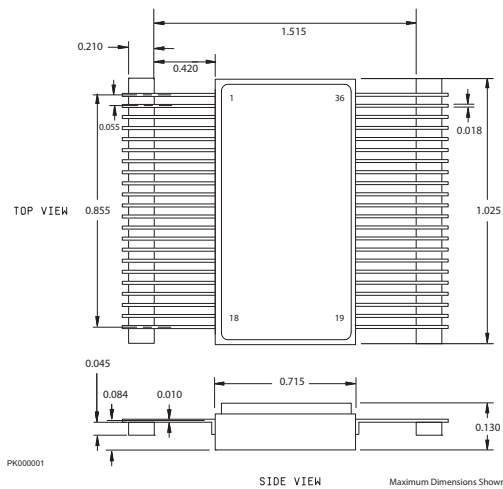

**FIGURE 12. BUS-63123 MECHANICAL OUTLINE 36-PIN FLAT PACK (0.050" PITCH)**

## SINGLE TRANSCEIVERS

### ORDERING INFORMATION

BUS-631XX-XX0X

**Supplemental Process Requirements:**

- S = Pre-Cap Source Inspection
- L = Pull Test
- Q = Pull Test and Pre-Cap Inspection
- K = One Lot Date Code
- W = One Lot Date Code and PreCap Source
- Y = One Lot Date Code and 100% Pull Test
- Z = One Lot Date Code, PreCap Source and 100% Pull Test
- Blank = None of the Above

**Process Requirements:**

- 0 = Standard DDC Processing, no Burn-In (See page xiii.)
- 1 = MIL-PRF-38534 Compliant
- 2 = B\*
- 3 = MIL-PRF-38534 Compliant with PIND Testing
- 4 = MIL-PRF-38534 Compliant with Solder Dip
- 5 = MIL-PRF-38534 Compliant with PIND Testing and Solder Dip
- 6 = B\* with PIND Testing
- 7 = B\* with Solder Dip
- 8 = B\* with PIND Testing and Solder Dip
- 9 = Standard DDC Processing with Solder Dip, no Burn-In (See page xiii.)

**Temperature Grade/Data Requirements:**

- 1 = -55°C to +125°C
- 2 = -40°C to +85°C
- 3 = 0°C to +70°C
- 4 = -55°C to +125°C with Variables Test Data
- 5 = -40°C to +85°C with Variables Test Data
- 8 = 0°C to +70°C with Variables Test Data

**Power Supply and Packaging**

- 5 = -15 V DDIP
- 6 = -15 V Flat Pack
- 7 = -12 V DDIP
- 8 = -12 V Flat Pack

**Encoder/Decoder Compatibility**

- 0 = Compatible with Harris Encoder/Decoder
- 1 = Compatible with Smith Encoder/Decoder

\*Standard DDC Processing with burn-in and full temperature. BUS-63105 also available as DESC drawing 5962-86049-02ZC. See FIGURE 2 for mating transformer.

### ORDERING INFORMATION

BUS-631XX-XX0X

**Supplemental Process Requirements:**

- S = Pre-Cap Source Inspection
- L = Pull Test
- Q = Pull Test and Pre-Cap Inspection
- K = One Lot Date Code
- W = One Lot Date Code and PreCap Source
- Y = One Lot Date Code and 100% Pull Test
- Z = One Lot Date Code, PreCap Source and 100% Pull Test
- Blank = None of the Above

**Process Requirements:**

- 0 = Standard DDC Processing, no Burn-In (See page xiii.)
- 1 = MIL-PRF-38534 Compliant
- 2 = B\*
- 3 = MIL-PRF-38534 Compliant with PIND Testing
- 4 = MIL-PRF-38534 Compliant with Solder Dip
- 5 = MIL-PRF-38534 Compliant with PIND Testing and Solder Dip
- 6 = B\* with PIND Testing
- 7 = B\* with Solder Dip
- 8 = B\* with PIND Testing and Solder Dip
- 9 = Standard DDC Processing with Solder Dip, no Burn-In (See page xiii.)

**Temperature Grade/Data Requirements:**

- 1 = -55°C to +125°C
- 2 = -40°C to +85°C
- 3 = 0°C to +70°C
- 4 = -55°C to +125°C with Variables Test Data
- 5 = -40°C to +85°C with Variables Test Data
- 8 = 0°C to +70°C with Variables Test Data

**Type**

- 2 = Universal Transceiver (MACAIR and 1553) ±12V to ±15 V power supply range. Compatible with Smith's Encoder/Decoder
- 4 = 1553, ±12V to ±15V power supply range, compatible with Smith's Encoder/Decoder

**Packaging**

- 0 = 24-Pin Square DIP
- 1 = 24-Pin Square Flat Pack

\*Standard DDC Processing with burn-in and full temperature test. See FIGURE 2 for mating transformer.

**Note:** The above products contain tin-lead solder finish as applicable to solder-dip requirements.

## DUAL TRANSCEIVERS

### ORDERING INFORMATION

BUS-631XX-XX0X

**Supplemental Process Requirements:**

- S = Pre-Cap Source Inspection
- L = Pull Test
- Q = Pull Test and Pre-Cap Inspection
- K = One Lot Date Code
- W = One Lot Date Code and PreCap Source
- Y = One Lot Date Code and 100% Pull Test
- Z = One Lot Date Code, PreCap Source and 100% Pull Test
- Blank = None of the Above

**Process Requirements\*:**

- 0 = Standard DDC Processing, no Burn-In (See page xiii.)
- 1 = MIL-PRF-38534 Compliant
- 2 = B\*
- 3 = MIL-PRF-38534 Compliant with PIND Testing
- 4 = MIL-PRF-38534 Compliant with Solder Dip
- 5 = MIL-PRF-38534 Compliant with PIND Testing and Solder Dip
- 6 = B\*\* with PIND Testing
- 7 = B\*\* with Solder Dip
- 8 = B\*\* with PIND Testing and Solder Dip
- 9 = Standard DDC Processing with Solder Dip, no Burn-In (See page xiii.)

**Temperature Grade/Data Requirements:**

- 1 = -55°C to +125°C
- 2 = -40°C to +85°C
- 3 = 0°C to +70°C
- 4 = -55°C to +125°C with Variables Test Data
- 5 = -40°C to +85°C with Variables Test Data
- 8 = 0°C to +70°C with Variables Test Data

**Power Supply and Packaging**

- 3 = -15V Flat Pack (0.050" pitch)
- 5 = -15 V DDIP
- 6 = -15 V Flat Pack
- 7 = -12 V DDIP
- 8 = -12 V Flat Pack

**Encoder/Decoder Compatibility**

- 2 = Compatible with Harris Encoder/Decoder
- 3 = Compatible with Smith Encoder/Decoder

\*Available as BUS-63125-641 (BUS-65612 compatible Transceiver).

\*\*Standard DDC Processing with burn-in and full temperature test.

BUS-63125 and BUS-63126 are available as DESC drawing 5962-87579.

See FIGURE 2 for mating transformer.

**Note:** The above products contain tin-lead solder finish as applicable to solder-dip requirements.

STANDARD DDC PROCESSING FOR HYBRID AND MONOLITHIC HERMETIC PRODUCTS		
TEST	MIL-STD-883	
	METHOD(S)	CONDITION(S)
INSPECTION	2009, 2010, 2017, and 2032	—
SEAL	1014	A and C
TEMPERATURE CYCLE	1010	C
CONSTANT ACCELERATION	2001	3000g
BURN-IN	1015 (note 1), 1030 (note 2)	TABLE 1

Notes:

1. For Process Requirement "B\*" (refer to ordering information), devices may be non-compliant with MIL-STD-883, Test Method 1015, Paragraph 3.2. Contact factory for details.
2. When applicable.

# NOTES

# NOTES

The information in this data sheet is believed to be accurate; however, no responsibility is assumed by Data Device Corporation for its use, and no license or rights are granted by implication or otherwise in connection therewith.  
Specifications are subject to change without notice.

Please visit our web site at [www.ddc-web.com](http://www.ddc-web.com) for the latest information.



105 Wilbur Place, Bohemia, New York, U.S.A. 11716-2426

**For Technical Support - 1-800-DDC-5757 ext. 7771**

**Headquarters, N.Y., U.S.A.** - Tel: (631) 567-5600, Fax: (631) 567-7358

**United Kingdom** - Tel: +44-(0)1635-811140, Fax: +44-(0)1635-32264

**France** - Tel: +33-(0)1-41-16-3424, Fax: +33-(0)1-41-16-3425

**Germany** - Tel: +49-(0)89-150012-11, Fax: +49-(0)89-150012-22

**Japan** - Tel: +81-(0)3-3814-7688, Fax: +81-(0)3-3814-7689

**Asia** - Tel: +65-6489-4801

**World Wide Web** - <http://www.ddc-web.com>



DATA DEVICE CORPORATION  
REGISTERED TO ISO 9001:2008  
REGISTERED TO AS9100:2004-01

PRINTED IN THE U.S.A.