

Ambassador[®] T8110L H.100/H.110 Switch

1 Introduction

The T8110L is the newest addition to the *Ambassador* series of TDM switching and backlane interconnect standard products. The T8110L can switch 4096 simultaneous time slots with 32 bidirectional local streams and 32 bidirectional H.100/H.110 streams. The T8110L has all the features of the T810X devices. Additionally, the T8110L has more robust clocking fallback abilities and is pin compatible with the T8110. (The full version of the T8110 has a PCI and minbridge interface.)

1.1 Features

- 4,096-connection unified switch
- Full H.100/H.110 support (32 data lines, all clock modes)
- 32 local I/O lines (2, 4, 8, or 16 Mbits/s)
- Microprocessor interface: *Motorola*[®]/*Intel*[®] modes
- Interrupt controller with external inputs
- Eight independent general-purpose I/O lines
- Eight independently programmed framing signals
- Four local clocks
- T1/E1 rate adaptation
- Two clock-fallback modes
- Stratum 4/4E and *AT&T*[®] 62411 MTIE compliant
- Incorporates 38 H.100 and 34 H.110 termination resistors
- Subrate switching of 4 bits, 2 bits, or 1 bit
- Backward compatible to all T810x devices
- Pin compatible with T8110
- JTAG/boundary-scan testing support
- BSDL files available
- Assists H.110 hot swap
- Single 3.3 V supply with 5 V tolerant inputs and TTL compatible outputs
- 272 PBGA package
- Evaluation boards available

Table of Contents

Contents	Page
1 Introduction	1
1.1 Features.....	1
2 Pin Description.....	10
2.1 Interface Signals.....	10
2.2 T8110L Pinout Information	12
2.3 Special Buffer Requirements	20
2.3.1 H1x0 Bus Signal Internal Pull-Up/Pull-Down	20
2.3.2 Local Bus Signal Internal Pull-Up	20
3 Main Architectural Features	21
3.1 T8110L Architecture	21
4 Microprocessor Interface	22
4.1 <i>Intel/Motorola</i> Protocol Selector.....	22
4.2 Word/Byte Addressing Selector.....	22
4.3 Access Via the Microprocessor Bus	23
4.3.1 Microprocessor Interface Register Map	24
4.3.2 Register Space Access.....	28
4.3.3 Connection Memory Space Access	28
4.3.4 Data Memory Space Access.....	29
5 Operating Control and Status	30
5.1 Control Registers	30
5.1.1 Reset Registers	30
5.1.2 Master Output Enable Register.....	31
5.1.3 Connection Control—Data Memory Selector Register	32
5.1.4 General Clock Control (Phase Alignment, Fallback, Watchdogs) Register	33
5.1.5 Phase Alignment Select Register	33
5.1.6 Fallback Control Register.....	33
5.1.7 Fallback Type Select Register	34
5.1.8 Fallback Trigger Registers	35
5.1.9 Watchdog Select, C8, and NETREF Registers.....	36
5.1.10 Watchdog EN Register	37
5.1.11 Failsafe Control Registers.....	38
5.2 Error and Status Registers	39
5.2.1 Clock Errors	40
5.2.1.1 Transient Clock Errors Registers.....	40
5.2.1.2 Latched Clock Error Register	41
5.2.2 System Status.....	42
5.2.2.1 Clock Fallback Status Register.....	42
5.2.2.2 Device Identification Registers	43
5.2.2.3 System Device Errors.....	43
6 Clock Architecture.....	44
6.1 Clock Input Control Registers	45
6.1.1 Main Input Selector Register.....	45
6.1.2 Main Divider Register.....	46
6.1.3 Analog PLL1 (APLL1) Input Selector Register	46
6.1.4 APLL1 Rate Register	47
6.1.5 Main Inversion Select Register	47
6.1.6 Resource Divider Register	48
6.1.7 Analog PLL2 (APLL2) Rate Register	48
6.1.8 LREF Input Select Registers.....	49
6.1.9 DPPLL1 Input Selector	50

Table of Contents (continued)

Contents	Page
6.1.9.1 DPLL1 Rate Register.....	50
6.1.10 DPLL2 Input Selector	50
6.1.10.1 DPLL2 Rate Register.....	51
6.1.11 NETREF1 Registers.....	51
6.1.12 NETREF2 Registers.....	52
6.2 Clock Output Control Registers	53
6.2.1 Master Output Enables Register	53
6.2.2 Clock Output Format Registers.....	54
6.2.3 TCLK and L_SCx Select Registers.....	55
6.3 Clock Register Access.....	57
6.4 Clock Circuit Operation—APLL1	57
6.4.1 Main Clock Selection, Bit Clock, and Frame	57
6.4.1.1 Watchdog Timers	58
6.4.1.2 Frame Center Sampling	59
6.4.1.3 LREF Pair Polarity Configuration.....	60
6.4.2 Main and Resource Dividers	61
6.4.3 DPLL1	61
6.4.4 Reference Selector	61
6.4.5 Internal Clock Generation	61
6.4.5.1 Phase Alignment	62
6.5 Clock Circuit Operation, APLL2	63
6.5.1 DPLL2	63
6.6 Clock Circuit Operation, CT_NETREF Generation.....	63
6.6.1 NETREF Source Select	63
6.6.2 NETREF Divider.....	63
6.7 Clock Circuit Operation—Fallback and Failsafe	64
6.7.1 Clock Fallback.....	64
6.7.1.1 Fallback Events	64
6.7.1.2 Fallback Scenarios—Fixed vs. Rotating Secondary.....	65
6.7.1.3 H-Bus Clock Enable/Disable on Fallback.....	68
6.7.2 Clock Failsafe	70
6.7.2.1 Failsafe Events.....	70
7 Frame Group and FG I/O	72
7.1 Frame Group Control Registers.....	72
7.1.1 FGx Lower and Upper Start Registers	72
7.1.2 FGx Width Registers	73
7.1.3 FGx Rate Registers	73
7.2 FG7 Timer Option	74
7.2.1 FG7 Counter (Low and High Byte) Registers.....	74
7.3 FGIO Control Registers	75
7.3.1 FGIO Data Register	75
7.3.2 FGIO Read Mask Register.....	75
7.3.3 FGIO R/W Register	76
7.4 FG Circuit Operation	77
7.4.1 Frame Group 8 kHz Reference Generation	78
7.4.2 FGIO General-Purpose Bits	79
7.4.3 Programmable Timer (FG7 Only).....	79
7.4.4 FG External Interrupts.....	79
7.4.5 FG Diagnostic Test Point Observation.....	79
8 General-Purpose I/O.....	80
8.1 GPIO Control Registers	80

Table of Contents (continued)

Contents	Page	
8.1.1	GPIO Data Register	80
8.1.2	GPIO Read Mask Register	81
8.1.3	GPIO R/W Register.....	81
8.1.4	GPIO Override Register.....	82
8.2	GP Circuit Operation.....	82
8.2.1	GPIO General-Purpose Bits.....	83
8.2.2	GP Dual-Purpose Bits GPIO (Override).....	83
8.2.2.1	GP H.110 Clock Master Indicators (GP0, GP1 Only).....	83
8.2.3	GP External Interrupts	83
8.2.4	GP Diagnostic Test Point Observation	83
9	Stream Rate Control	84
9.1	H-Bus Stream Rate Control Registers.....	85
9.1.1	H-Bus Rate Registers	85
9.2	L-Bus Stream Rate Control Registers	85
9.2.1	L-Bus Rate Registers	85
9.2.2	L-Bus 16.384 Mbits/s Operation	86
9.2.3	16.384 Mbits/s Local I/O Superrate	88
9.2.4	16.384 Mbits/s Local I/O Superrate	89
10	Error Reporting and Interrupt Control	90
10.1	Interrupt Control Registers.....	90
10.1.1	Interrupts Via External FG[7:0] Registers	90
10.1.1.1	FGIO Interrupt Pending Register.....	90
10.1.2	Interrupts Via External GP[7:0]	92
10.1.2.1	GPIO Interrupt Pending Register.....	92
10.1.2.2	GPIO Edge/Level and GPIO Polarity Registers	93
10.1.3	Interrupts Via Internal System Errors.....	93
10.1.4	System Interrupt Pending High/Low Registers	94
10.1.5	System Interrupt Enable High/Low Registers	95
10.1.6	Interrupts Via Internal Clock Errors.....	96
10.1.7	Clock Interrupt Pending High/Low Registers	97
10.1.8	Clock Interrupt Enable High/Low Registers	98
10.1.9	Interrupt Servicing Registers.....	99
10.1.9.1	Arbitration Control Register	99
10.1.9.2	SYSERR and CLKERR Output Select Register.....	99
10.1.9.3	Interrupt In-Service Registers.....	101
10.2	Error Reporting and Interrupt Controller Circuit Operation	103
10.2.1	Externally Sourced Interrupts Via FG[7:0], GP[7:0]	104
10.2.2	Internally Sourced System Error Interrupts.....	104
10.2.3	Internally Sourced Clock Error Interrupts.....	104
10.2.4	Arbitration of Pending Interrupts	104
10.2.4.1	Arbitration Off	104
10.2.4.2	Flat Arbitration	104
10.2.4.3	Tier Arbitration.....	104
10.2.4.4	Pre-Emptying Disabled.....	105
10.2.4.5	Pre-Emptying Enabled	105
10.2.5	CLKERR Output.....	105
10.2.6	SYSERR Output	105
10.2.7	System Handling of Interrupts.....	105
11	Test and Diagnostics	106
11.1	Diagnostics Control Registers	106
11.1.1	FG Testpoint Enable Register.....	106

Table of Contents (continued)

Contents	Page
11.1.2 GP Testpoint Enable Register	108
11.1.3 State Counter Modes Registers	110
11.1.4 Miscellaneous Diagnostics Low Register	110
11.1.5 Miscellaneous Diagnostic Registers	111
11.2 Diagnostic Circuit Operation	112
12 Connection Control	113
12.1 Programming Interface	113
12.1.1 Connection Memory Programming	113
12.2 Switching Operation	115
12.2.1 Memory Architecture and Configuration	115
12.2.1.1 Connection Memory	115
12.2.1.2 Data Memory	116
12.2.2 Standard Switching	117
12.2.2.1 Constant Delay and Minimum Delay Connections	117
12.2.2.2 Pattern Mode	117
12.2.2.3 Substrate	117
13 Electrical Characteristics	124
13.1 Absolute Maximum Ratings	124
13.1.1 Handling Precautions	124
13.2 Crystal Specifications	124
13.2.1 XTAL1 Crystal	124
13.2.2 XTAL2 Crystal	125
13.2.3 Reset Pulse	126
13.3 Thermal Parameters (Definitions and Values)	126
13.4 Reliability	127
13.5 dc Electrical Characteristics	128
13.5.1 Electrical Drive Specifications, CT_C8 and /CT_FRAME	128
13.5.2 All Other Pins	129
13.6 H-Bus Timing	129
13.6.1 Timing Diagrams	129
13.7 ac Electrical Characteristics	130
13.7.1 Skew Timing, H-Bus	130
13.8 Hot Swap	131
13.8.1 LPUE (Local Pull-Up Enable)	131
13.9 Decoupling	131
13.10 APLL VDD Filter	132
13.11 PC Board PBGA Considerations	133
13.12 Unused Pins	133
13.13 External Pull-Up Pins	133
13.14 T8110L Evaluation Kits	133
13.15 T8110L Ordering Information	133
14 JTAG/Boundary Scan	137
14.1 The Principle of Boundary-Scan Architecture	137
14.1.1 Instruction Register	138
14.2 Boundary-Scan Register	138
A Constant and Minimum Delay Connections	139
A.1 Connection Definitions	139
A.2 Delay Type Definitions	139
B Register Bit Field Mnemonic Summary	142
Significant Changes Between the June 2003 and November 2003 Release	163

List of Figures

Figure	Page
Figure 1. T8110L Pull-Up/Pull-Down Arrangement for H1x0 Pins	20
Figure 2. T8110L Architecture Block Diagram	21
Figure 3. Microprocessor Access Timing, <i>Intel</i> Protocol	26
Figure 4. Microprocessor Access Timing, <i>Motorola</i> Protocol	27
Figure 5. T8110L Main Clocking Paths	44
Figure 6. T8110L NETREF Paths	44
Figure 7. T8110L Required Frame Pulse and Bit Clock with Polarities	60
Figure 8. T8110L Phase Alignment, SNAP and SLIDE	62
Figure 9. Fallback—Fixed vs. Rotating Secondary	65
Figure 10. T8110L Clock Fallback States	66
Figure 11. T8110L H-Bus Clock Enable States	68
Figure 12. T8110L Clock Failsafe States	70
Figure 13. FG[7:0] Functional Paths	77
Figure 14. Frame Group 8 kHz Reference Timing	78
Figure 15. GP[7:0] Functional Paths	82
Figure 16. Local Stream 16.384 Mb/s Timing	86
Figure 17. Local Stream 16.384 Mb/s Circuit	87
Figure 18. Superrate I/O Configuration	88
Figure 19. Relationship Between 8.192 Mb/s and 16.384 Mb/s Time Slots	89
Figure 20. Interrupt Controller	103
Figure 21. Microprocessor Programming—Reset Page Command	114
Figure 22. Microprocessor Programming—Make/Break/Query Telephony Connections	114
Figure 23. T8110L Data Memory Map and Configurations	116
Figure 24. TDM Data Stream Bit Rates	118
Figure 25. Subrate Switching Example, Byte Packing	121
Figure 26. Subrate Switching Example, Byte Unpacking	123
Figure 27. Clock Alignment	129
Figure 28. Frame Timing Diagram	130
Figure 29. Detailed Clock Skew Timing Diagram	130
Figure 30. APLL VDD Filtering	132
Figure 31. T8110L Pins by Functional Group	134
Figure 32. <i>IEEE</i> [®] 1149.1 Boundary-Scan Architecture	137
Figure 33. Constant Delay Connection Latency	140
Figure 34. Minimum Delay Connection Latency	141

List of Tables

Table	Page
Table 1. Microprocessor Interface Signals	10
Table 2. H-Bus (H.100/H.110 Interface) Signals	10
Table 3. L-Bus (Local) Interface Signals	10
Table 4. Clock Circuit Interface Signals	11
Table 5. GPIO Interface Signals.....	11
Table 6. Miscellaneous Interface Signals.....	11
Table 7. JTAG Signals	11
Table 8. T8110L Pinouts	13
Table 9. <i>Intel/Motorola</i> Protocol Selector	22
Table 10. T8110L Memory Mapping to Microprocessor Space.....	23
Table 11. Microprocessor Interface Register Map	24
Table 12. Register Space Access Timing	28
Table 13. Connection Memory Space Access Timing.....	28
Table 14. Data Memory Space Access Timing	29
Table 15. Control Register Map	30
Table 16. Reset Registers.....	31
Table 17. Master Output Enable Register	32
Table 18. Data Memory Mode Select Register	32
Table 19. Clock Register Access Select Register	33
Table 20. Phase Alignment Select Register.....	33
Table 21. Fallback Control Register	34
Table 22. Fallback Type Select Register.....	35
Table 23. Fallback Trigger Registers	35
Table 24. Watchdog Select, C8, NETREF Registers	36
Table 25. Watchdog EN Registers	37
Table 26. Failsafe Control Register.....	38
Table 27. Error and Status Register Map.....	39
Table 28. Clock Error Registers	40
Table 29. Latched Clock Error Registers	41
Table 30. Fallback and Failsafe Status Register.....	42
Table 31. System Errors Registers	43
Table 32. Device Identification Registers	43
Table 33. Clock Input Control Register Map	45
Table 34. Main Input Selector Register	45
Table 35. Main Divider Register	46
Table 36. APLL1 Input Selector Register	46
Table 37. APLL1 Rate Register.....	47
Table 38. Main Inversion Select Register.....	47
Table 39. Resource Divider Register	48
Table 40. APLL2 Rate Register.....	48
Table 41. LREF Input/Inversion Select Registers	49
Table 42. DPLL1 Input Selector Registers	50
Table 43. DPLL2 Register	51
Table 44. NETREF1 Registers.....	51
Table 45. NETREF2 Registers.....	52
Table 46. Clock Output Control Register Map.....	53
Table 47. Master Output Enables Registers	54
Table 48. Clock Output Format Registers	55
Table 49. TCLK Select and L_SCx Select Registers	56
Table 50. Bit Clock and Frame.....	57

List of Tables (continued)

Table	Page
Table 51. Watchdog Timer Description	58
Table 52. Frame Center Sampling	59
Table 53. Legacy Mode Fallback Event Triggers	65
Table 54. Clock Fallback State Description.....	67
Table 55. H-Bus Clock Enable State Description.....	69
Table 56. Clock Failsafe State Descriptions.....	71
Table 57. Frame Group and FG I/O Register Map.....	72
Table 58. FGx Lower and Upper Start Registers	72
Table 59. FGx Width Registers	73
Table 60. FGx Rate Registers	73
Table 61. FG7 Counter (Low and High Byte) Registers.....	74
Table 62. FGIO Data Register.....	75
Table 63. FGIO Read Mask Register	75
Table 64. FGIO R/W Register	76
Table 65. GPIO Register	80
Table 66. GPIO Data Register	80
Table 67. GPIO Read Mask Register	81
Table 68. GPIO R/W Register	81
Table 69. GPIO Override Register	82
Table 70. T8110L Serial Stream Groupings.....	84
Table 71. H-Bus Rate Registers.....	85
Table 72. L-Bus Rate Registers	85
Table 73. Interrupt Control Register Map	90
Table 74. FGIO Interrupt Pending Registers.....	90
Table 75. FGIO Edge/Level and Polarity Registers	91
Table 76. GPIO Interrupt Pending Register	92
Table 77. GPIO Edge/Level and GPIO Polarity Registers	93
Table 78. System Error Interrupt Assignments	93
Table 79. System Interrupt Pending High/Low Registers.....	94
Table 80. System Interrupt Enable High/Low Registers.....	95
Table 81. Clock Error Interrupt Assignments	96
Table 82. Clock Interrupt Pending High/Low Registers.....	97
Table 83. Clock Interrupt Enable High/Low Registers.....	98
Table 84. Arbitration Control Register	99
Table 85. SYSERR Output Select Registers.....	100
Table 86. Interrupt In-Service Register	101
Table 87. Diagnostics Control Register Map.....	106
Table 88. FG Testpoint Enable Registers	106
Table 89. FG[7:0] Internal Testpoint Assignments	107
Table 90. Testpoint Enable Registers	108
Table 91. GP[7:0] Internal Testpoint Assignments.....	109
Table 92. State Counter Modes Registers	110
Table 93. Miscellaneous Diagnostics Low Register	110
Table 94. Miscellaneous Diagnostic Registers.....	111
Table 95. Microprocessor Programming, Connection Memory Access	113
Table 96. TDM Data Stream	118
Table 97. Subrate Switching, Data Propagation Rate vs. Channel Capacity.....	119
Table 98. Subrate Switching, Connection Memory Programming Setup	120
Table 99. Absolute Maximum Ratings.....	124
Table 100. XTAL1 Specifications	124

List of Tables (continued)

Table	Page
Table 101. 16.384 MHz Oscillator Requirements.....	125
Table 102. XTAL2 Specifications	125
Table 103. 6.176 MHz/12.352 MHz Oscillator Requirements	125
Table 104. Reset Pulse	126
Table 105. Thermal Parameter Values.....	127
Table 106. Reliability Data.....	127
Table 107. Electrical Drive Specifications, CT_C8 and /CT_FRAME.....	128
Table 108. dc Electrical Characteristics, All Other Pins	129
Table 109. Skew Timing, H-Bus.....	130
Table 110. L_SC[3:0] and Frame Group Rise and Fall Time	131
Table 111. T8110L Ordering Information	133
Table 112. Instruction Register.....	138
Table 113. Special Cases (Exceptions).....	141
Table 114. Mnemonic Summary, Sorted by Name.....	143
Table 115. Mnemonic Summary, Sorted by Register.....	153
Table 116. Changes	163

2 Pin Description

2.1 Interface Signals

Table 1. Microprocessor Interface Signals

Signal	I/O	Width	Microprocessor Interface Function
A	I	20	Address[19:0] in.
D	I/O	16	Data bus in/out.
RD# (DS#)	I	1	RDn(DSn) in.
WR# (R/W#)	I	1	WRn(R/Wn) in.
CSN	I	1	CSn in.
WB_SEL	I	1	Word/byte select in.
RDY (DTACK#)	Out	1	RDY(DTACKn) out.
IM_SEL	I	1	Intel/Motorola select in.

Table 2. H-Bus (H.100/H.110 Interface) Signals

Signal	I/O	Width	Function
VPRECHARGE	In	1	Precharge voltage for pull-downs, H.110 bus signals: CT_D, CT_NETREF1, CT_NETREF2.
H110_ENABLE	In	1	Pull-down enable for H.110 bus signals: CT_D, CT_NETREF1, CT_NETREF2.
H100_ENABLE	In	1	Pull-up enable for H.100 bus signals: CT_D, CT_NETREF1, CT_NETREF2, CT_C8_A, CT_C8_B, /CT_FRAME_A, /CT_FRAME_B.
CT_D	I/O	32	H.100/H.110 bus data.
CT_C8_A	I/O	1	H.100/H.110 bit clock A.
/CT_FRAME_A	I/O	1	H.100/H.110 frame reference A.
CT_C8_B	I/O	1	H.100/H.110 bit clock B.
/CT_FRAME_B	I/O	1	H.100/H.110 frame reference B.
CT_NETREF1	I/O	1	H.100/H.110 network reference 1.
CT_NETREF2	I/O	1	H.100/H.110 network reference 2.
/C16+	I/O	1	H-MVIP™ compatibility clock (16.384 MHz, differential).
/C16-	I/O	1	H-MVIP compatibility clock (16.384 MHz, differential).
/C4	I/O	1	MVIP compatibility clock (4.096 MHz).
C2	I/O	1	MVIP compatibility clock (2.048 MHz).
SCLK	I/O	1	SC-bus compatibility clock.
/SCLKx2	I/O	1	SC-bus compatibility clock.
/FR_COMP	I/O	1	Compatibility frame reference.

Table 3. L-Bus (Local) Interface Signals

Signal	I/O	Width	Function
L_D	I/O	32	Local bus data.
L_SC	Out	4	Local bus clock outputs.
FG	I/O	8	Local frame groups.

2 Pin Description (continued)

2.1 Interface Signals (continued)

Table 4. Clock Circuit Interface Signals

Signal	I/O	Width	Function
XTAL1_IN	In	1	Crystal oscillator #1 input (16.384 MHz).
XTAL1_OUT	Out	1	Crystal oscillator #1 feedback.
XTAL2_IN	In	1	Crystal oscillator #2 input (6.176 MHz or 12.352 MHz).
XTAL2_OUT	Out	1	Crystal oscillator #2 feedback.
LREF	In	8	Local clock reference inputs.
TCLK_OUT	Out	1	Internal chip clock output.
PRI_REF_OUT	Out	1	Main divider reference out for CLAD/DJAT.
PRI_REF_IN	In	1	CLAD/DJAT reference in for APLL1.
NR1_SEL_OUT	Out	1	CT_NETREF1 selection out for CLAD/DJAT.
NR1_DIV_IN	In	1	CLAD/DJAT reference in for CT_NETREF1 divider.
NR2_SEL_OUT	Out	1	CT_NETREF2 selection out for CLAD/DJAT.
NR2_DIV_IN	In	1	CLAD/DJAT reference in for CT_NETREF2 divider.

Table 5. GPIO Interface Signals

Signal	I/O	Width	GPIO Function	Alternate Function
GP0	I/O	1	GPIO bit 0 I/O	A-master indicator out.
GP1	I/O	1	GPIO bit 1 I/O	B-master indicator out.
GP2	I/O	1	GPIO bit 2 I/O	—
GP3	I/O	1	GPIO bit 3 I/O	—
GP4	I/O	1	GPIO bit 4 I/O	—
GP5	I/O	1	GPIO bit 5 I/O	—
GP6	I/O	1	GPIO bit 6 I/O	—
GP7	I/O	1	GPIO bit 7 I/O	—

Table 6. Miscellaneous Interface Signals

Signal	I/O	Width	Function
RESET#	In	1	Chip reset.
SYSERR	Out	1	System error indicator.
CLKERR	Out	1	Clocking error indicator.
LPUE	In	1	Pull-up enable for signals: FG, GP, L_D, LREF, D, NR1_DIV_IN, NR2_DIV_IN, PRI_REF_IN.
PEN	In	1	Reserved. Must be left unconnected.
TESTMODE	In	1	Reserved. Must be left unconnected.

Table 7. JTAG Signals

Signal	I/O	Width	Function
TRST#	In	1	JTAG reset.
TCK	In	1	JTAG clock.
TMS	In	1	JTAG mode select.
TDI	In	1	JTAG data in.
TDO	Out	1	JTAG data out.

2 Pin Description (continued)

2.2 T8110L Pinout Information

The T8110L package is a 272-pin PBGA ball grid array. Refer to the table below for ball assignment, buffer type, and pull-up/pull-down information.

Note: The pull-up/down column in the following table is defined as follows:

- 20 k Ω down—20 k Ω pull-down resistor is always in-circuit.
- 50 k Ω up—50 k Ω pull-up resistor is always in-circuit.
- LPUE: 50 k Ω up—when LPUE = 1, a 50 k Ω pull-up resistor is in-circuit.
- Enabled: 50 k Ω up/20 k Ω Vpre—when H100_ENABLE = 1, a 50 k Ω pull-up resistor is in-circuit (see Figure 1 on page 20). When H110_ENABLE = 1, a 20 k Ω pull-down resistor from the VPRECHARGE input to this signal is in-circuit.

2 Pin Description (continued)

2.2 T8110L Pinout Information (continued)

Table 8. T8110L Pinouts

Microprocessor Interface			
Ball	Pin Name	Buffer Type	Pull-Up/Down (see note on page 12)
F1	A0	8 mA I/O-Schmitt	20 kΩ down
G1	A1	8 mA I/O-Schmitt	20 kΩ down
K3	A10	8 mA I/O-Schmitt	20 kΩ down
J3	A11	8 mA I/O-Schmitt	20 kΩ down
K1	A12	8 mA I/O-Schmitt	20 kΩ down
K2	A13	8 mA I/O-Schmitt	20 kΩ down
L3	A14	8 mA I/O-Schmitt	20 kΩ down
L4	A15	8 mA I/O-Schmitt	20 kΩ down
G2	A2	8 mA I/O-Schmitt	20 kΩ down
G3	A3	8 mA I/O-Schmitt	20 kΩ down
H1	A4	8 mA I/O-Schmitt	20 kΩ down
H2	A5	8 mA I/O-Schmitt	20 kΩ down
H3	A6	8 mA I/O-Schmitt	20 kΩ down
J4	A7	8 mA I/O-Schmitt	20 kΩ down
J1	A8	8 mA I/O-Schmitt	20 kΩ down
J2	A9	8 mA I/O-Schmitt	20 kΩ down
W1	D0	8 mA I/O-Schmitt	LPUE: 50 kΩ up
V1	D1	8 mA I/O-Schmitt	LPUE: 50 kΩ up
V2	D2	8 mA I/O-Schmitt	LPUE: 50 kΩ up
U3	D3	8 mA I/O-Schmitt	LPUE: 50 kΩ up
U1	D4	8 mA I/O-Schmitt	LPUE: 50 kΩ up
U2	D5	8 mA I/O-Schmitt	LPUE: 50 kΩ up
T3	D6	8 mA I/O-Schmitt	LPUE: 50 kΩ up
T4	D7	8 mA I/O-Schmitt	LPUE: 50 kΩ up
T1	D8	8 mA I/O-Schmitt	LPUE: 50 kΩ up
T2	D9	8 mA I/O-Schmitt	LPUE: 50 kΩ up
R3	D10	8 mA I/O-Schmitt	LPUE: 50 kΩ up
P4	D11	8 mA I/O-Schmitt	LPUE: 50 kΩ up
R1	D12	8 mA I/O-Schmitt	LPUE: 50 kΩ up
R2	D13	8 mA I/O-Schmitt	LPUE: 50 kΩ up
P2	D14	8 mA I/O-Schmitt	LPUE: 50 kΩ up
P3	D15	8 mA I/O-Schmitt	LPUE: 50 kΩ up
N1	RD#(DS#)	8 mA I/O-Schmitt	LPUE: 50 kΩ up
P1	WR#(R/W#)	8 mA I/O-Schmitt	LPUE: 50 kΩ up
L1	A16	8 mA I/O-Schmitt	20 kΩ down
L2	A17	8 mA I/O-Schmitt	20 kΩ down
M1	A18	8 mA I/O-Schmitt	20 kΩ down
M2	A19	8 mA I/O-Schmitt	20 kΩ down
M3	CSN	8 mA I/O-Schmitt	LPUE: 50 kΩ up
M4	WB_SEL	8 mA I/O-Schmitt	LPUE: 50 kΩ up
N2	RDY(DTACK#)	8 mA 3-state	External pull-up required
N3	IM_SEL	8 mA I/O-Schmitt	LPUE: 50 kΩ up

2 Pin Description (continued)**2.2 T8110L Pinout Information** (continued)**Table 8. T8110L Pinouts** (continued)

H-Bus Interface			
Ball	Pin Name	Buffer Type	Pull-Up/Down (see note on page 12)
C1	VPRECHARGE	Op amp noninvert	—
D5	H110_ENABLE	Input	20 k Ω down
D7	H100_ENABLE	Input	20 k Ω down
A11	CT_D0	PCI I/O	Enabled: 50 k Ω up/20 k Ω Vpre
B11	CT_D1	PCI I/O	Enabled: 50 k Ω up/20 k Ω Vpre
C10	CT_D2	PCI I/O	Enabled: 50 k Ω up/20 k Ω Vpre
C11	CT_D3	PCI I/O	Enabled: 50 k Ω up/20 k Ω Vpre
A10	CT_D4	PCI I/O	Enabled: 50 k Ω up/20 k Ω Vpre
B10	CT_D5	PCI I/O	Enabled: 50 k Ω up/20 k Ω Vpre
B9	CT_D6	PCI I/O	Enabled: 50 k Ω up/20 k Ω Vpre
C9	CT_D7	PCI I/O	Enabled: 50 k Ω up/20 k Ω Vpre
A9	CT_D8	PCI I/O	Enabled: 50 k Ω up/20 k Ω Vpre
B8	CT_D9	PCI I/O	Enabled: 50 k Ω up/20 k Ω Vpre
C8	CT_D10	PCI I/O	Enabled: 50 k Ω up/20 k Ω Vpre
A8	CT_D11	PCI I/O	Enabled: 50 k Ω up/20 k Ω Vpre
C7	CT_D12	PCI I/O	Enabled: 50 k Ω up/20 k Ω Vpre
A7	CT_D13	PCI I/O	Enabled: 50 k Ω up/20 k Ω Vpre
B7	CT_D14	PCI I/O	Enabled: 50 k Ω up/20 k Ω Vpre
C6	CT_D15	PCI I/O	Enabled: 50 k Ω up/20 k Ω Vpre
A6	CT_D16	PCI I/O	Enabled: 50 k Ω up/20 k Ω Vpre
B6	CT_D17	PCI I/O	Enabled: 50 k Ω up/20 k Ω Vpre
C5	CT_D18	PCI I/O	Enabled: 50 k Ω up/20 k Ω Vpre
A5	CT_D19	PCI I/O	Enabled: 50 k Ω up/20 k Ω Vpre
B5	CT_D20	PCI I/O	Enabled: 50 k Ω up/20 k Ω Vpre
A4	CT_D21	PCI I/O	Enabled: 50 k Ω up/20 k Ω Vpre
B4	CT_D22	PCI I/O	Enabled: 50 k Ω up/20 k Ω Vpre
C4	CT_D23	PCI I/O	Enabled: 50 k Ω up/20 k Ω Vpre
A3	CT_D24	PCI I/O	Enabled: 50 k Ω up/20 k Ω Vpre
B3	CT_D25	PCI I/O	Enabled: 50 k Ω up/20 k Ω Vpre
C3	CT_D26	PCI I/O	Enabled: 50 k Ω up/20 k Ω Vpre
A2	CT_D27	PCI I/O	Enabled: 50 k Ω up/20 k Ω Vpre
B2	CT_D28	PCI I/O	Enabled: 50 k Ω up/20 k Ω Vpre
B1	CT_D29	PCI I/O	Enabled: 50 k Ω up/20 k Ω Vpre
C2	CT_D30	PCI I/O	Enabled: 50 k Ω up/20 k Ω Vpre
D2	CT_D31	PCI I/O	Enabled: 50 k Ω up/20 k Ω Vpre
A13	CT_C8_A	24 mA I/O-Schmitt	Enabled: 50 k Ω up
A12	/CT_FRAME_A	24 mA I/O-Schmitt	Enabled: 50 k Ω up
B13	CT_C8_B	24 mA I/O-Schmitt	Enabled: 50 k Ω up
B12	/CT_FRAME_B	24 mA I/O-Schmitt	Enabled: 50 k Ω up
A14	CT_NETREF1	PCI I/O	Enabled: 50 k Ω up/20 k Ω Vpre
B14	CT_NETREF2	PCI I/O	Enabled: 50 k Ω up/20 k Ω Vpre
D9	/C16+	24 mA I/O-Schmitt	50 k Ω up

2 Pin Description (continued)

2.2 T8110L Pinout Information (continued)

Table 8. T8110L Pinouts (continued)

H-Bus Interface (continued)			
Ball	Pin Name	Buffer Type	Pull-Up/Down (see note on page 12)
D10	/C16-	24 mA I/O-Schmitt	50 kΩ up
D12	/C4	8 mA I/O-Schmitt	50 kΩ up
D14	C2	8 mA I/O-Schmitt	50 kΩ up
C14	SCLK	24 mA I/O-Schmitt	50 kΩ up
C13	/SCLKX2	24 mA I/O-Schmitt	50 kΩ up
C12	/FR_COMP	24 mA I/O-Schmitt	50 kΩ up
J20	LD0	8 mA I/O-Schmitt	LPUE: 50 kΩ up
J19	LD1	8 mA I/O-Schmitt	LPUE: 50 kΩ up
J18	LD2	8 mA I/O-Schmitt	LPUE: 50 kΩ up
K17	LD3	8 mA I/O-Schmitt	LPUE: 50 kΩ up
K20	LD4	8 mA I/O-Schmitt	LPUE: 50 kΩ up
K19	LD5	8 mA I/O-Schmitt	LPUE: 50 kΩ up
K18	LD6	8 mA I/O-Schmitt	LPUE: 50 kΩ up
L18	LD7	8 mA I/O-Schmitt	LPUE: 50 kΩ up
L20	LD8	8 mA I/O-Schmitt	LPUE: 50 kΩ up
L19	LD9	8 mA I/O-Schmitt	LPUE: 50 kΩ up
M18	LD10	8 mA I/O-Schmitt	LPUE: 50 kΩ up
M17	LD11	8 mA I/O-Schmitt	LPUE: 50 kΩ up
M20	LD12	8 mA I/O-Schmitt	LPUE: 50 kΩ up
M19	LD13	8 mA I/O-Schmitt	LPUE: 50 kΩ up
N19	LD14	8 mA I/O-Schmitt	LPUE: 50 kΩ up
N18	LD15	8 mA I/O-Schmitt	LPUE: 50 kΩ up
N20	LD16	8 mA I/O-Schmitt	LPUE: 50 kΩ up
P20	LD17	8 mA I/O-Schmitt	LPUE: 50 kΩ up
P19	LD18	8 mA I/O-Schmitt	LPUE: 50 kΩ up
P18	LD19	8 mA I/O-Schmitt	LPUE: 50 kΩ up
R20	LD20	8 mA I/O-Schmitt	LPUE: 50 kΩ up
R19	LD21	8 mA I/O-Schmitt	LPUE: 50 kΩ up
R18	LD22	8 mA I/O-Schmitt	LPUE: 50 kΩ up
P17	LD23	8 mA I/O-Schmitt	LPUE: 50 kΩ up
T20	LD24	8 mA I/O-Schmitt	LPUE: 50 kΩ up
T19	LD25	8 mA I/O-Schmitt	LPUE: 50 kΩ up
T18	LD26	8 mA I/O-Schmitt	LPUE: 50 kΩ up
U20	LD27	8 mA I/O-Schmitt	LPUE: 50 kΩ up
V20	LD28	8 mA I/O-Schmitt	LPUE: 50 kΩ up
U19	LD29	8 mA I/O-Schmitt	LPUE: 50 kΩ up
U18	LD30	8 mA I/O-Schmitt	LPUE: 50 kΩ up
T17	LD31	8 mA I/O-Schmitt	LPUE: 50 kΩ up
H20	L_SC0	8 mA 3-state	—
H19	L_SC1	8 mA 3-state	—
H18	L_SC2	8 mA 3-state	—
G19	L_SC3	8 mA 3-state	—

2 Pin Description (continued)**2.2 T8110L Pinout Information** (continued)**Table 8. T8110L Pinouts** (continued)

L-Bus Interface			
Ball	Pin Name	Buffer Type	Pull Up/Down (see note on page 12)
Y20	FG0	8 mA I/O-Schmitt	LPUE: 50 kΩ up
Y19	FG1	8 mA I/O-Schmitt	LPUE: 50 kΩ up
W20	FG2	8 mA I/O-Schmitt	LPUE: 50 kΩ up
W19	FG3	8 mA I/O-Schmitt	LPUE: 50 kΩ up
W18	FG4	8 mA I/O-Schmitt	LPUE: 50 kΩ up
V19	FG5	8 mA I/O-Schmitt	LPUE: 50 kΩ up
V18	FG6	8 mA I/O-Schmitt	LPUE: 50 kΩ up
V17	FG7	8 mA I/O-Schmitt	LPUE: 50 kΩ up
B20	XTAL1_IN	Input	—
C19	XTAL1_OUT	Crystal feedback	—
E20	XTAL2_IN	Input	—
F19	XTAL2_OUT	Crystal feedback	—
A15	LREF0	Input-Schmitt	LPUE: 50 kΩ up
B15	LREF1	Input-Schmitt	LPUE: 50 kΩ up
C15	LREF2	Input-Schmitt	LPUE: 50 kΩ up
C16	LREF3	Input-Schmitt	LPUE: 50 kΩ up
A16	LREF4	Input-Schmitt	LPUE: 50 kΩ up
B16	LREF5	Input-Schmitt	LPUE: 50 kΩ up
Clock Circuit Interface			
Ball	Pin Name	Buffer Type	Pull Up/Down (see note on page 12)
B17	LREF6	Input-Schmitt	LPUE: 50 kΩ up
C17	LREF7	Input-Schmitt	LPUE: 50 kΩ up
G20	TCLK_OUT	8 mA 3-state	—
A17	PRI_REF_OUT	8 mA 3-state	—
A18	PRI_REF_IN	Input-Schmitt	LPUE: 50 kΩ up
B18	NR1_SEL_OUT	8 mA 3-state	—
A19	NR1_DIV_IN	Input-Schmitt	LPUE: 50 kΩ up
D19	NR2_SEL_OUT	8 mA 3-state	—
C20	NR2_DIV_IN	Input-Schmitt	LPUE: 50 kΩ up
GPIO Interface			
Ball	Pin Name	Buffer Type	Pull Up/Down (see note on page 12)
D1	GP0/AMASTER	8 mA I/O-Schmitt	LPUE: 50 kΩ up
E1	GP1/BMASTER	8 mA I/O-Schmitt	LPUE: 50 kΩ up
E2	GP2	8 mA I/O-Schmitt	LPUE: 50 kΩ up
F2	GP3	8 mA I/O-Schmitt	LPUE: 50 kΩ up
D3	GP4	8 mA I/O-Schmitt	LPUE: 50 kΩ up
F3	GP5	8 mA I/O-Schmitt	LPUE: 50 kΩ up
E3	GP6	8 mA I/O-Schmitt	LPUE: 50 kΩ up
E4	GP7	8 mA I/O-Schmitt	LPUE: 50 kΩ up

2 Pin Description (continued)

2.2 T8110L Pinout Information (continued)

Table 8. T8110L Pinouts (continued)

Miscellaneous Interfaces			
Ball	Pin Name	Buffer Type	Pull Up/Down (see note on page 12)
Y1	RESET#	Input-Schmitt	50 kΩ up
V3	SYSERR	8 mA 3-state	—
W2	CLKERR	8 mA 3-state	—
J17	LPUE	Input	50 kΩ up
A20	PEN	Input	50 kΩ up. This pin is unused and must be left unconnected.
F20	TESTMODE	Input	20 kΩ up. This pin is unused and must be left unconnected.
JTAG Interface			
Ball	Pin Name	Buffer Type	Pull Up/Down (see note on page 12)
C18	TRST#	Input-Schmitt	50 kΩ up
E18	TCK	Input-Schmitt	50 kΩ up
D18	TMS	Input-Schmitt	50 kΩ up
F18	TDI	Input-Schmitt	50 kΩ up
G18	TDO	4 mA 3-state	—
Power			
Ball	Pin Name	Buffer Type	Pull Up/Down
B19	APLL1VDD	Analog VDD	—
E19	APLL2VDD	Analog VDD	—
D6	VDD	—	—
D11	VDD	—	—
D15	VDD	—	—
F4	VDD	—	—
F17	VDD	—	—
K4	VDD	—	—
L17	VDD	—	—
R4	VDD	—	—
R17	VDD	—	—
U6	VDD	—	—
U10	VDD	—	—
U15	VDD	—	—
Ground			
Ball	Pin Name	Buffer Type	Pull Up/Down
A1	Vss	—	—
D4	Vss	—	—
D8	Vss	—	—
D13	Vss	—	—
D17	Vss	—	—
H4	Vss	—	—
H17	Vss	—	—

2 Pin Description (continued)

2.2 T8110L Pinout Information (continued)

Table 8. T8110L Pinouts (continued)

Ground (continued)			
Ball	Pin Name	Buffer Type	Pull Up/Down
N4	VSS	—	—
N17	VSS	—	—
U4	VSS	—	—
U8	VSS	—	—
U13	VSS	—	—
U17	VSS	—	—
U5	VSS	—	—
U11	VSS	—	—
U16	VSS	—	—
W5—W9	VSS	—	—
W10	VSS	—	—
W13—W17	VSS	—	—
V4—V9	VSS	—	—
V13—V16	VSS	—	—
Y5—Y9	VSS	—	—
Y13—Y18	VSS	—	—
Thermal Ground			
J9—12	—	—	—
K9—12	—	—	—
L9—12	—	—	—
M9—12	—	—	—
No Connects			
D16	No connects must be left unconnected.		
D20			
E17			
G17			
G4			
W3			
V12			
Y4			

2 Pin Description (continued)

2.2 T8110L Pinout Information (continued)

Table 8. T8110L Pinouts (continued)

External Pull-Up			
Ball	Pin Name	Buffer Type	Pull Up/Down
U7	EPU	—	—
U9	EPU	—	—
U12	EPU	—	—
U14	EPU	—	—
V10	EPU	—	—
V11	EPU	—	—
W4	EPU	—	—
W11	EPU	—	—
W12	EPU	—	—
Y2	EPU	—	—
Y3	EPU	—	—
Y10	EPU	—	—
Y11	EPU	—	—
Y12	EPU	—	—

Note: The EPU pins must be tied to an external pull-up resistor. Multiple pins may share a common resistor. It is recommended that all EPU pins be tied to a common 20 kΩ pull-up resistor.

2 Pin Description (continued)

2.3 Special Buffer Requirements

2.3.1 H1x0 Bus Signal Internal Pull-Up/Pull-Down

The H1x0 bus pins require special consideration for H.100 and H.110 usage. There are two control pins to select between various internal bus pull-ups/pull-downs, as shown below:

- H100_ENABLE. Enables internal 50 kΩ pull-ups on CT_Dn, CT_NETREF1, CT_NETREF2, CT_C8_A, CT_C8_B, /CT_FRAME_A, and /CT_FRAME_B signals.
- H110_ENABLE. Enables internal 20 kΩ pull-downs on all 32 CT_Dn signals, CT_NETREF1, and CT_NETREF2 to the VPRECHARGE signal.

Note: The two H1x0 enables are active-high. Only one or the other should ever be asserted.

Warning: Do not assert both at the same time.

Please refer to Figure 1 for more detail.

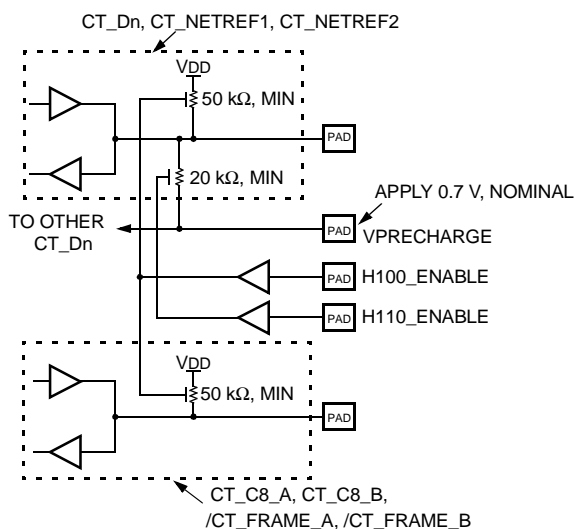

5-9611 (F)

Figure 1. T8110L Pull-Up/Pull-Down Arrangement for H1x0 Pins

2.3.2 Local Bus Signal Internal Pull-Up

The LPUE input is active-high; and is used to activate pull-ups on the following local signals: GP[7:0], FG[7:0], D[15:0], LD[31:0], LREF[7:0], PRI_REF_IN, NR1_DIV_IN, and NR2_DIV_IN.

3 Main Architectural Features

3.1 T8110L Architecture

The T8110L includes all of the clocking and standard switching functions found on previous *Ambassador* devices, plus additional functionalities that are described in the following sections. The T8110L interfaces to a controller via a standard microprocessor interface which is described in Section 4. Note that the full version of the device, the T8110, contains both microprocessor and PCI interfaces, allowing the device to attach directly to a PCI bus. The T8110L and T8110 are pin compatible.

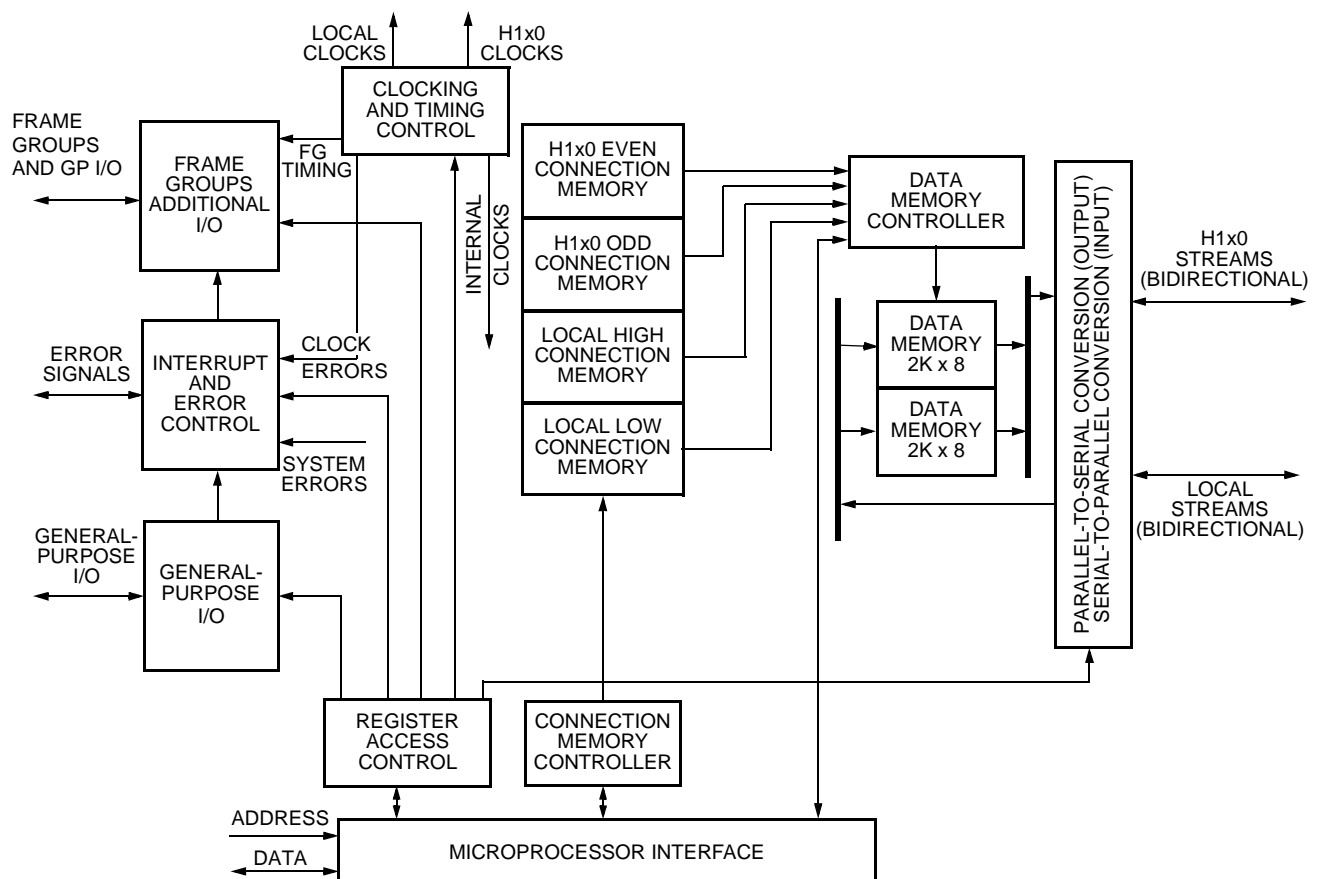

5-8920 (F)

Figure 2. T8110L Architecture Block Diagram

4 Microprocessor Interface

4.1 Intel/Motorola Protocol Selector

IM_SEL = 1 is the default, if left unconnected, and selects an *Intel* handshake protocol.
IM_SEL = 0 selects a *Motorola* handshake protocol.

Note: The IM_SEL signal must be static (either pulled high or pulled low).

Table 9. Intel/Motorola Protocol Selector

<i>Intel/Motorola Protocol Selector</i>		
Signal	<i>Intel</i> Mnemonic	<i>Motorola</i> Mnemonic
D[15:0]	D[15:0]	D[15:0]
A[19:0]	A[15:0]	A[15:0]
CSN	CSn	CSn
RDY (DTACK#)	RDY	DTACKn
RD# (DS#)	RDn (read strobe)	DSn (data strobe)
WR# (R/W#)	WRn (write strobe)	R/Wn (read/write selector)
WB_SEL	Default	Default
IM_SEL	Default	Default

4.2 Word/Byte Addressing Selector

WB_SEL = 1 is the default, if left unconnected, and selects 16-bit word aligned addressing.
WB_SEL = 0 selects 8-bit byte aligned addressing.

Note: The WB_SEL signal may be static or dynamic in nature. If dynamic, WB_SEL must follow the same timing requirements as the address bus.

Word-aligned addressing produces 16-bit data transfers via D[15:0]. Byte-aligned addressing produces 8-bit data transfers via D[7:0] (D[15:8] is unused). The T8110L internal data bus is 32 bits, so A[1:0] address bits are decoded along with WB_SEL to control a dword-to-word or dword-to-byte swap function back to the data bus.

4 Microprocessor Interface (continued)

4.3 Access Via the Microprocessor Bus

The T8110L microprocessor bus interface allows access to three internal regions: registers, connection memory, and data memory. All microprocessor bus asynchronous strobes are synchronized to the T8110L's internal 65.536 MHz clock domain. There are 20 address bits provided to address the internal regions and these are defined in Table 10.

Table 10. T8110L Memory Mapping to Microprocessor Space

Region	Subregion	Range (hex)
Registers	Reserved	0x00000—0x000FF
	Operating control and status	0x00100—0x001FF
	Clocks	0x00200—0x002FF
	Rate control	0x00300—0x003FF
	Frame group	0x00400—0x004FF
	General-purpose I/O	0x00500—0x005FF
	Interrupt control	0x00600—0x006FF
	Reserved	0x00700—0x007FF
	Reserved	0x00800—0x0FFFF
Reserved	—	0x10000—0x1FFFF
Data memory	—	0x20000—0x2FFFF
Reserved	—	0x30000—0x3FFFF
Connection memory	—	0x40000—0x4FFFF
Reserved	—	0x50000—0xFFFFF

4 Microprocessor Interface (continued)**4.3 Access Via the Microprocessor Bus** (continued)**4.3.1 Microprocessor Interface Register Map**

The T8110L registers map into the microprocessor bus space as follows.

Table 11. Microprocessor Interface Register Map

DWORD Address (20 bits)	Cross Reference	Register			
		Byte 3	Byte 2	Byte 1	Byte 0
0x00100	5.1.1, 5.1.2	Master enable	Reserved	Reset select	Soft reset
0x00104	5.1.3, 5.1.4	Phase alignment select	Clock register access select	Data memory mode select	Reserved
0x00108	5.1.4	Fallback trigger, upper	Fallback trigger, lower	Fallback type select	Fallback control
0x0010C	5.1.4	Watchdog EN, upper	Watchdog EN, lower	Watchdog select, NETREF	Watchdog select, C8
0x00114	4.1.5	Reserved	Failsafe sensitivity	Failsafe enable	Failsafe control
0x00118	6.1.11	Reserved	OOL monitor	OOL threshold high	OOL threshold low
0x00120	5.2.1	Status 3, latched clock errors, upper	Status 2, latched clock errors, lower	Status 1, transient clock errors, upper	Status 0, transient clock errors, lower
0x00124	5.2.2	Status 7, system errors	Reserved	Reserved	Status 4
0x00128	5.2.2.2	Device ID, upper	Device ID, lower	Reserved	Version ID
0x00140	11.1	Diag3	Diag2	Diag1	Diag0
0x00144	11.1	Diag7	Diag6	Diag5	Diag4
0x00148	11.1	Diag11	Diag10	Diag9	Diag8
0x00200	6.1	APLL1 rate	APLL1 input selector	Main divider	Main input selector
0x00204	6.1	APLL2 rate	Reserved	Resource divider	Main inversion select
0x00208	6.1	DPLL1 rate	DPLL1 input selector	Reserved	LREF input select
0x0020C	6.1	DPLL2 rate	DPLL2 input selector	Reserved	LREF inversion select
0x00210	6.1	Reserved	NETREF1 LREF select	NETREF1 divider	NETREF1 input selector
0x00214	6.1	Reserved	NETREF2 LREF select	NETREF2 divider	NETREF2 input selector
0x00220	6.2	C8 output rate	/FR_COMP width	NETREF output enables	Master output enables
0x00224	6.2	SCLK output rate	TCLK select	Reserved	CCLK output enables
0x00228	6.2	L_SC3 select	L_SC2 select	L_SC1 select	L_SC0 select
0x00300	9.1	H-bus rate H/G	H-bus rate F/E	H-bus rate D/C	H-bus rate B/A
0x00320	9.2	L-bus rate H/G	L-bus rate F/E	L-bus rate D/C	L-bus rate B/A
0x00400	7.1	FG0 rate	FG0 width	FG0 upper start	FG0 lower start

4 Microprocessor Interface (continued)

4.3 Access Via the Microprocessor Bus (continued)

4.3.1 Microprocessor Interface Register Map (continued)

Table 11. Microprocessor Interface Register Map (continued)

DWORD Address (20 bits)	Cross Reference	Register			
		Byte 3	Byte 2	Byte 1	Byte 0
0x00410	7.1	FG1 rate	FG1 width	FG1 upper start	FG1 lower start
0x00420	7.1	FG2 rate	FG2 width	FG2 upper start	FG2 lower start
0x00430	7.1	FG3 rate	FG3 width	FG3 upper start	FG3 lower start
0x00440	7.1	FG4 rate	FG4 width	FG4 upper start	FG4 lower start
0x00450	7.1	FG5 rate	FG5 width	FG5 upper start	FG5 lower start
0x00460	7.1	FG6 rate	FG6 width	FG6 upper start	FG6 lower start
0x00470	7.1	FG7 rate	FG7 width	FG7 upper start	FG7 lower start
0x00474	7.2	FG7 mode upper	FG7 mode lower	FG7 counter high byte	FG7 counter low byte
0x00480	7.3	Reserved	FGIO R/W	FGIO read mask	FGIO data register
0x00500	8.1	GPIO override	GPIO R/W	GPIO read mask	GPIO data register
0x00600	12.1	FGIO interrupt polarity	Reserved	FGIO interrupt enable	FGIO interrupt pending
0x00604	10.1	GPIO interrupt polarity	Reserved	GPIO interrupt enable	GPIO interrupt pending
0x00608	10.1	System interrupt enable, upper	System interrupt enable, lower	System interrupt pending, upper	System interrupt pending, lower
0x0060C	10.1	Clock interrupt enable, upper	Clock interrupt enable, lower	Clock interrupt pending, upper	Clock interrupt pending, lower
0x00610	10.1	CLKERR output select	SYSERR output select	Reserved	Arbitration control
0x00614	10.1	CLKERR pulse width	SYSERR pulse width	Reserved	Reserved
0x006FC	10.1	Reserved	Reserved	In-service, high	In-service, low

4 Microprocessor Interface (continued)

4.3 Access Via the Microprocessor Bus (continued)

4.3.1 Microprocessor Interface Register Map (continued)

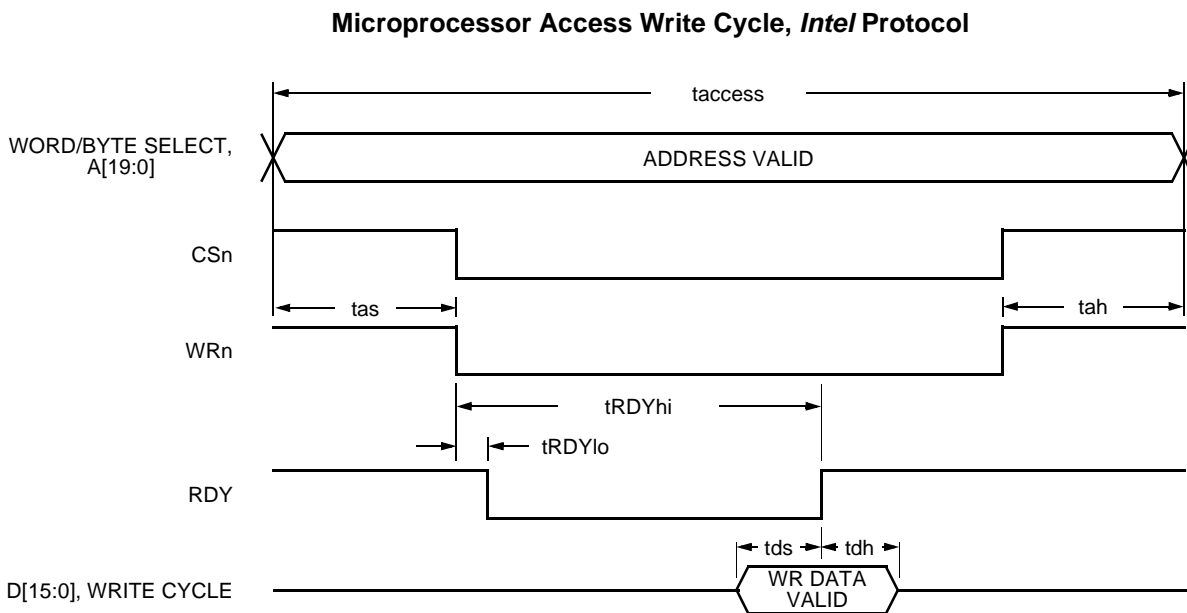
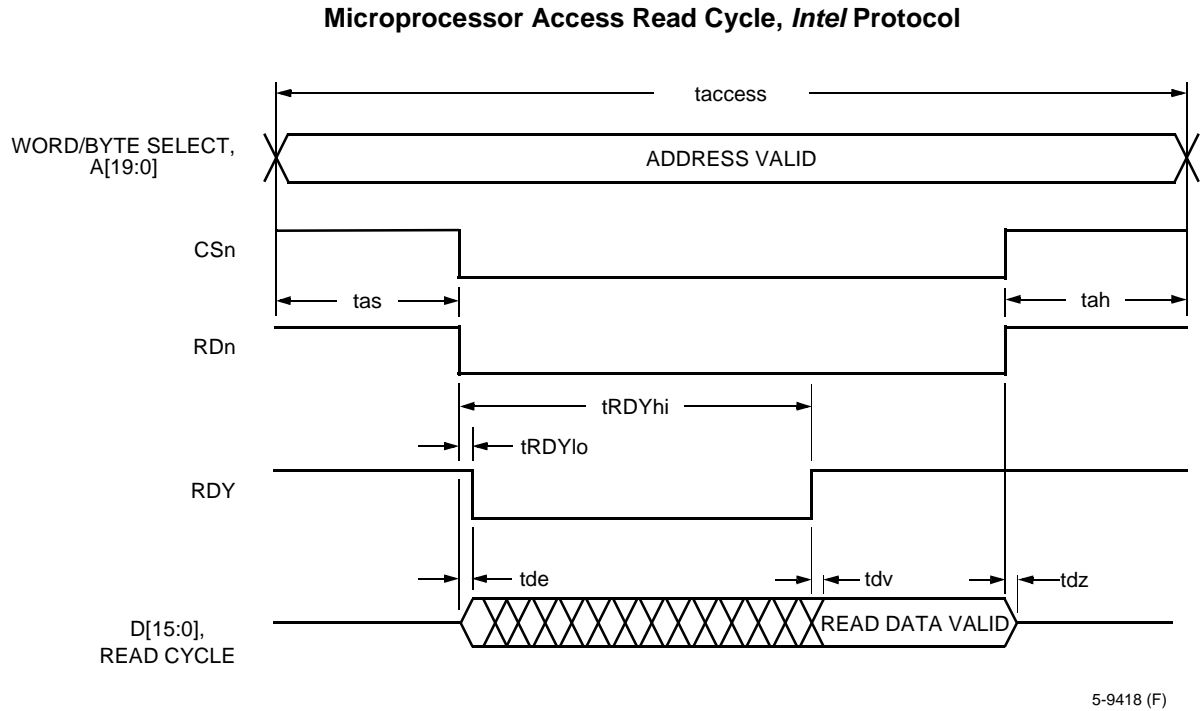

Figure 3. Microprocessor Access Timing, Intel Protocol

4 Microprocessor Interface (continued)

4.3 Access Via the Microprocessor Bus (continued)

4.3.1 Microprocessor Interface Register Map (continued)

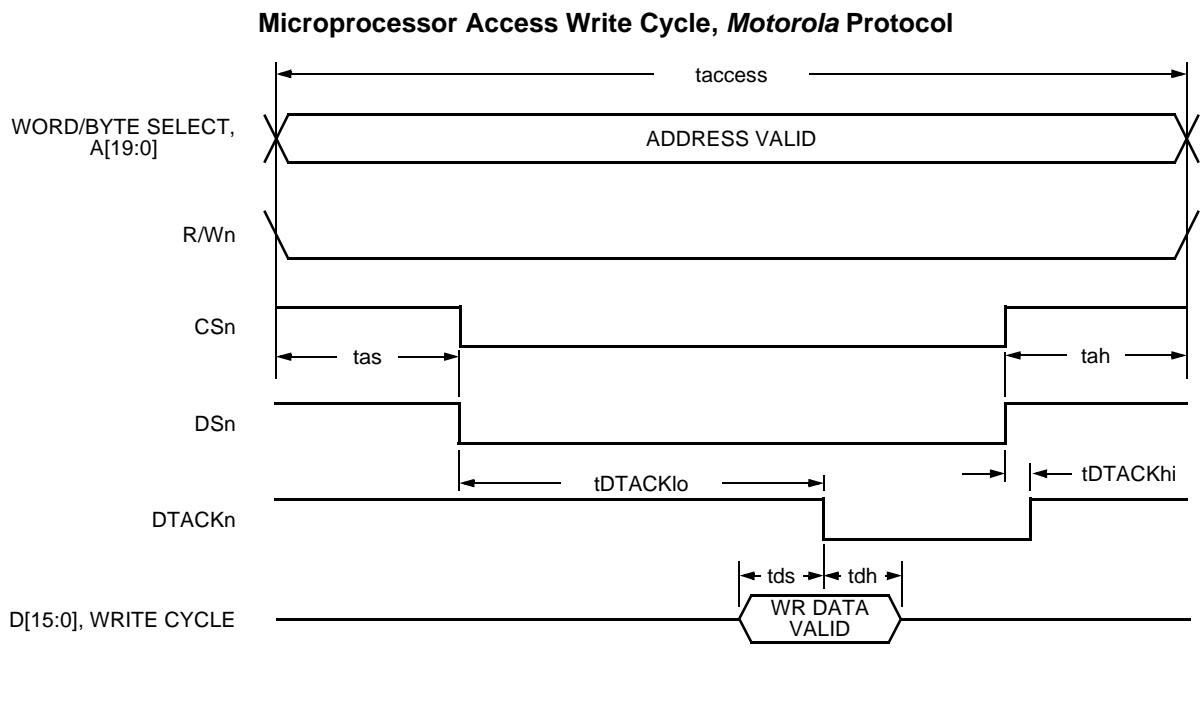
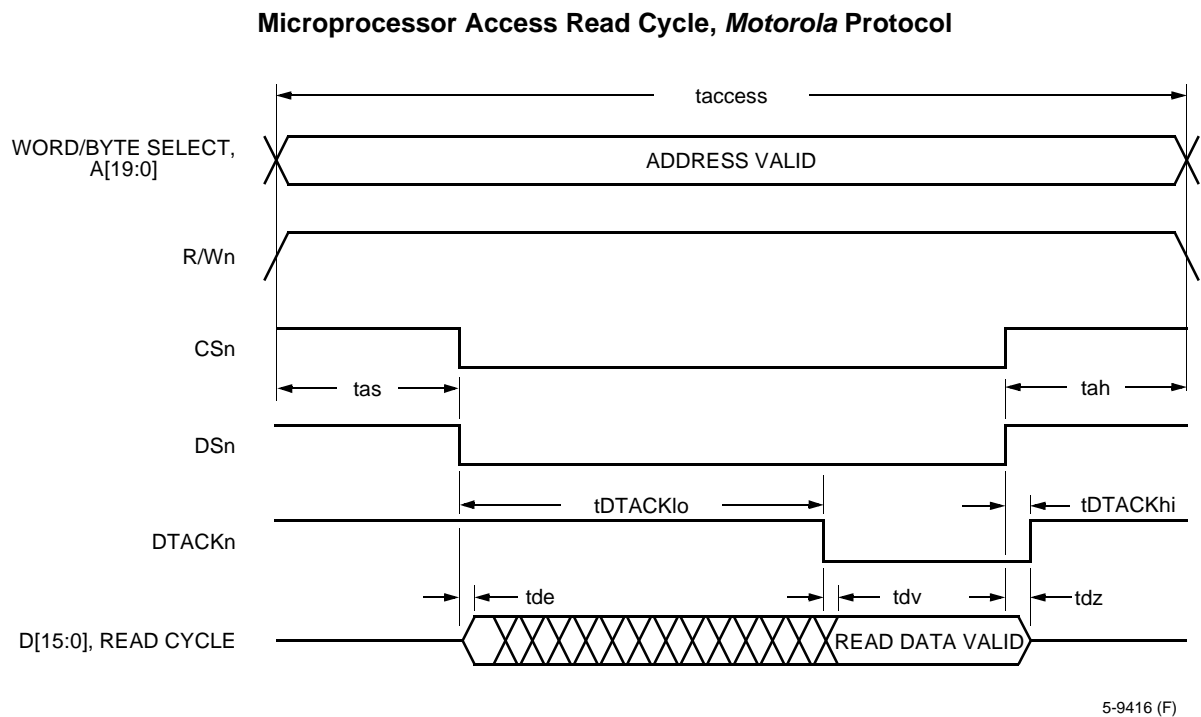

Figure 4. Microprocessor Access Timing, *Motorola* Protocol

4 Microprocessor Interface (continued)

4.3 Access Via the Microprocessor Bus (continued)

4.3.2 Register Space Access

The T8110L registers are always immediately available for access, providing low latency time to acknowledge the transaction. Read access to [reserved] addresses returns 0x00. Register access timing for Figure 3 and Figure 4 is shown below.

Table 12. Register Space Access Timing

Name	Parameter	Min (ns)	Max (ns)
taccess	Overall Access Time	41	—
tas	Address Setup Time	5	—
tah	Address Hold Time	0	—
tRDYlo	<i>Intel Cycle</i> , Time to RDY Deasserted	6	12
tRDYhi	<i>Intel Cycle</i> , Time to RDY Reasserted	36	72
tDTACKlo	<i>Motorola Cycle</i> , Time to DTACKn Asserted	36	70
tDTACKhi	<i>Motorola Cycle</i> , Time to DTACKn Deasserted	10	15
tde	Read Cycle, Time to Data Enabled	7	14
tdv	Read Cycle, Time to Data Valid	5	9
tdz	Read Cycle, Time to Data Invalid	10	16
tds	Write Cycle, Data Setup Time	25	—
tdh	Write Cycle, Data Hold Time	0	—

4.3.3 Connection Memory Space Access

The T8110L connection memory is always immediately available for access (via dedicated access times assigned for microprocessor transactions) providing low latency time to acknowledge the transaction. Connection memory access timing for Figure 3 and Figure 4 is shown below.

Table 13. Connection Memory Space Access Timing

Name	Parameter	Min (ns)	Max (ns)
taccess	Overall Access Time	41	—
tas	Address Setup Time	5	—
tah	Address Hold Time	0	—
tRDYlo	<i>Intel Cycle</i> , Time to RDY Deasserted	6	12
tRDYhi	<i>Intel Cycle</i> , Time to RDY Reasserted	36	72
tDTACKlo	<i>Motorola Cycle</i> , Time to DTACKn Asserted	36	70
tDTACKhi	<i>Motorola Cycle</i> , Time to DTACKn Deasserted	10	15
tde	Read Cycle, Time to Data Enabled	7	14
tdv	Read Cycle, Time to Data Valid	5	9
tdz	Read Cycle, Time to Data Invalid	10	16
tds	Write Cycle, Data Setup Time	25	—
tdh	Write Cycle, Data Hold Time	0	—

4 Microprocessor Interface (continued)

4.3 Access Via the Microprocessor Bus (continued)

4.3.4 Data Memory Space Access

The T8110L data memory is not guaranteed to be immediately available for access. Access to data memory is prioritized for standard H-bus/L-bus switching, with microprocessor bus transaction access allowed as the lowest priority. The latency time to acknowledge these transactions is indeterminate and depends on the H-bus/L-bus switching configuration. Data memory access timing for Figure 3 and Figure 4 is shown below.

Table 14. Data Memory Space Access Timing

Name	Parameter	Min (ns)	Max (ns)
taccess	Overall Access Time	41	—*
tas	Address Setup Time	5	—
tah	Address Hold Time	0	—
tRDYlo	<i>Intel Cycle</i> , Time to RDY Deasserted	6	12
tRDYhi	<i>Intel Cycle</i> , Time to RDY Reasserted	36	—*
tDTACKlo	<i>Motorola Cycle</i> , Time to DTACKn Asserted	36	—*
tDTACKhi	<i>Motorola Cycle</i> , Time to DTACKn Deasserted	10	15
tde	Read Cycle, Time to Data Enabled	7	14
tdv	Read Cycle, Time to Data Valid	5	9
tdz	Read Cycle, Time to Data Invalid	10	16
tds	Write Cycle, Data Setup Time	25	—
tdh	Write Cycle, Data Hold Time	0	—

* Max data memory space access time is indeterminate, and depends on how much of the data memory access bandwidth is being taken by TDM switch connections.

5 Operating Control and Status

Overall T8110L operational control and status is configured via registers occupying 0x00100—0x001FC in the address space.

5.1 Control Registers

General control functions are soft reset, reset configuration, overall master output enables, and data memory configuration. Clocking-specific general control functions are clock register access configuration, phase alignment, clock fallback, and clock watchdog configuration.

Table 15. Control Register Map

DWORD Address (20 Bits)	Register			
	Byte 3	Byte 2	Byte 1	Byte 0
0x00100	Master enable	Reserved	Reset select	Soft reset
0x00104	Phase alignment select	Clock register access select	Data memory mode select	—
0x00108	Fallback trigger, upper	Fallback trigger, lower	Fallback type select	Fallback control
0x0010C	Watchdog EN, upper	Watchdog EN, lower	Watchdog select, NETREF	Watchdog select, C8
0x00114	Reserved	Failsafe threshold low	Failsafe enable and status	Failsafe control

5.1.1 Reset Registers

The soft reset and reset select registers control soft reset functions and reset signal masking. Writes to the soft reset register trigger the corresponding action, and the set bit(s) are automatically cleared.

- **Power-on reset:** nonmaskable:
 - At power-on, initialize all T8110L registers (including reset select register) and connection valid flags. The power-on reset cell test input is controlled via diagnostic register; see Section 11.
- **Hard reset:** maskable via reset select register, HRBEB:
 - On assertion of RESET#, initialize all T8110L registers (excluding reset select register) and connection valid flags.

Soft resets are maskable via reset select register, SRBEB, and selectable via soft reset register, SRESR.

- Soft reset 1: Initialize all T8110L registers (excluding reset select register) and connection valid flags.
- Soft reset 2: Initialize all T8110L registers (excluding reset select register).
- Soft reset 3: Reset all interrupt pending registers and the interrupt in-service register.
- Soft reset 4: Reset the interrupt in-service register only.

5 Operating Control and Status (continued)

5.1 Control Registers (continued)

Table 16. Reset Registers

Byte Address	Name	Bit(s)	Mnemonic	Value	Function
0x00100	Soft Reset	7:0	SRESR	0000 0000 0000 0001 0000 0010 0001 0000 0010 0000	NOP (default value). Reset all registers and connection valid flags. Reset all registers. Reset interrupt pending and in-service registers. Reset interrupt in-service register only.
0x00101	Reset Select	7:2	Reserved	0000	NOP (default).
		1	HRBEB	0 1	Disable hard reset to back end. Enable hard reset to back end (default).
		0	SRBEB	0 1	Disable soft resets to back end. Enable soft resets to back end (default).

5.1.2 Master Output Enable Register

The master output enable register is used to control master output enables to various groups of T8110L signals, including the following:

- L-bus data streams (L_D[31:0])
- L-bus clocks (L_SC[3:0], FG[7:0] when used as frame group outputs)
- H-bus data streams (CT_D[31:0])
- H-bus clocks (CT_C8_A, /CT_FRAME_A, CT_C8_B, /CT_FRAME_B, CT_NETREF1, CT_NETREF2, /C16+, /C16-, /C4, C2, SCLK, /SCLKx2, /FR_COMP)
- GPIO (GP[7:0])
- FGIO (FG[7:0] when used as programmable register outputs)

T8110L outputs that are not programmatically enabled (i.e., always driven except during reset) include the following:

CLKERR, SYSERR, PRI_REF_OUT, NR1_SEL_OUT, and NR2_SEL_OUT.

5 Operating Control and Status (continued)

5.1 Control Registers (continued)

Table 17. Master Output Enable Register

Byte Address	Name	Bit(s)	Mnemonic	Value	Function
0x00103	Master Enable	7	AIOEB	0	Individual enables via bits [6:0] (default).
				1	Enable all (same as bits [6:0] = 1111111).
		6	Reserved	0	NOP.
				1	
		5	FGREB	0	Disable FGIO (default).
				1	Enable FGIO.
		4	GPIEB	0	Disable GPIO (default).
				1	Enable GPIO.
3	HCKEB	0	Disable H-bus clocks (default).		
		1	Enable H-bus clocks.		
2	HDBEB	0	Disable H-bus data streams (default).		
		1	Enable H-bus data streams.		
1	LCKEB	0	Disable L-bus clocks, L_SC, FG (default).		
		1	Enable L-bus clocks.		
0	LDBEB	0	Disable L-bus data streams (default).		
		1	Enable L-bus data streams.		

5.1.3 Connection Control—Data Memory Selector Register

The data memory mode select register MSbit controls subrate switching enable. The lower 7 bits control the T8110L data memory switching configuration. For more details, see Section 12.2.1.2 on page 116.

There are three data memory configurations as outlined below:

1. 4k single-buffered switch. Standard H-bus/L-bus switching only, up to 4096 simplex connections, all connections are minimum delay due to single-buffer configuration.
2. 2k double-buffered switch. Standard H-bus/L-bus switching only, up to 2048 simplex connections, all connections are programmable for minimum or constant delay via the double-buffer configuration.
3. 2k single-buffered switch + 1k double-buffered switch. Standard H-bus/L-bus switching only, up to 2048 simplex minimum delay connections (single buffer) and up to 1024 simplex minimum or constant delay connections (double buffer).

Table 18. Data Memory Mode Select Register

Byte Address	Name	Bit(s)	Mnemonic	Value	Function
0x00105	Data Memory Mode Select	7	GSREB	0	Disable subrate switching (default).
				1	Enable subrate switching.
		6:0	DMMSP	100 0000	4k single-buffer switch (default).
010 0000	2k double-buffer switch.				
011 0000	2k single-buffer, 1k double-buffer switch.				

5 Operating Control and Status (continued)

5.1 Control Registers (continued)

5.1.4 General Clock Control (Phase Alignment, Fallback, Watchdogs) Register

The clock register access select register controls the selection between accessing the active vs. the inactive set of T8110L clock registers. The T8110L contains two sets of clock registers, X and Y. The X and Y register sets are comprised of the registers listed in Table 33 on page 45, Clock Input Control Register Map, and Table 46 on page 53, Clock Output Control Register Map. Only one set is used at a time. It is selected based on the clock fallback setup. The clock register set that is currently in use is denoted as the active set; see Section 6.3 on page 57 for more details.

Table 19. Clock Register Access Select Register

Byte Address	Name	Bit(s)	Mnemonic	Value	Function
0x00106	Clock Register Access Select	7:0	CSASR	0000 0000 0000 0001	Access inactive clock registers (default). Access active clock registers.

5.1.5 Phase Alignment Select Register

The phase alignment select register selects the phase alignment configuration. For more details, see Section 6.4.5.1 on page 62. The T8110L internally generates an 8 kHz frame reference. Shown below are three configurations to control phase alignment between this internally generated frame reference and a selected incoming frame reference from the H-bus (/CT_FRAME_A, /CT_FRAME_B, or /FR_COMP) or local clock reference (LREF[4:7]).

- Disable alignment, no realignment of unaligned frames
- Snap alignment, immediate realignment of unaligned frames
- Slide alignment, gradual realignment of unaligned frames

Table 20. Phase Alignment Select Register

Byte Address	Name	Bit(s)	Mnemonic	Value	Function
0x00107	Phase Alignment Select	7:0	PAFSR	0000 0000 0000 0001 0000 0010	Phase alignment is disabled (default). Enable snap alignment. Enable slide alignment.

5.1.6 Fallback Control Register

The fallback control register allows user control over the active and inactive clock register sets. For more details, see Section 6.7.1 on page 64. Writes to the fallback control register trigger the corresponding action, and the set bit(s) are automatically cleared. The four commands are shown below:

- GO_CLOCKS. At initialization, the clock register Y set is active, the X set is inactive, and access is enabled to the X set. The GO_CLOCKS command transitions the Y set to inactive and the X set to active. This command can either be performed immediately upon issue or can wait to be performed until the next 8 kHz frame reference (synchronized to frame).
- CLEAR_FALLBACK. Forces a state transition for active/inactive assignment of the clock register X and Y sets after a fallback event has occurred. This command can either be performed immediately upon issue or can wait to be performed until the next 8 kHz frame reference (synchronized to frame).

5 Operating Control and Status (continued)

5.1 Control Registers (continued)

5.1.6 Fallback Control Register (continued)

- **FORCE_FALLBACK.** Forces a state transition for active/inactive assignment of the clock register X and Y sets by creating a fallback event. This command can either be performed immediately upon issue or can wait to be performed until the next 8 kHz frame reference (synchronized to frame).
- **COPY ACTIVE TO INACTIVE SET.** Copies all register values in the current active clock register set to the inactive clock register set. This command is performed immediately upon issue.

Table 21. Fallback Control Register

Byte Address	Name	Bit(s)	Mnemonic	Value	Function
0x00108	Fallback Control	7:0	FBCSR	0000 0000 0000 0001 0000 0010 0000 0100 0001 0001 0001 0010 0001 0100 0010 0000	NOP (default). GO_CLOCKS command. CLEAR_FALLBACK command. FORCE_FALLBACK command. GO_CLOCKS synchronized to frame*. CLEAR_FALLBACK synchronized to frame*. FORCE_FALLBACK synchronized to frame*. COPY ACTIVE TO INACTIVE SET command.

* The synchronized to frame command also has a diagnostic element—instead of performing the command right at the frame boundary, the user can elect to perform the command at a specified offset time from the frame boundary, by programming the Diag11 and Diag10 registers, 0x0014B—0x0014A.

5.1.7 Fallback Type Select Register

The upper nibble configures which H-bus clocks are selected to trigger a clock fallback event. Any of the **legacy** modes have predetermined trigger enables and ignore the fallback trigger register settings. Nonlegacy modes require the fallback trigger register settings. For more details, see Section 6.7.1 on page 64.

The lower nibble configures the state machine that controls clock register set active/inactive assignments. There are three possible selections. For more details, see Section 6.7 on page 64.

- **Disabled.** No transitions of clock register X and Y sets to active/inactive.
- **Fixed secondary.** Swap the active/inactive sets on a fallback event; swap them back when fallback is cleared.
- **Rotating secondary.** Swap the active/inactive sets on a fallback event; maintain this state when fallback is cleared.

5 Operating Control and Status (continued)

5.1 Control Registers (continued)

5.1.7 Fallback Type Select Register (continued)

Table 22. Fallback Type Select Register

Byte Address	Name	Bit(s)	Mnemonic	Value	Function
0x00109	Fallback Type Select	7:4	FTRSN	0000 0001 0010 0100 1000 1001	NOP (default). Legacy, fallback to OSC/4 on main select failure. Legacy, fallback X/Y set on main select failure. Legacy, fallback X/Y set on H-bus A/B failure. Fallback trigger registers control fallback. Fallback trigger registers control fallback and H-Bus clock enable state machine is enabled.
		3:0	FSMSN	0000 0001 0010	Fallback is disabled (default). Enable fixed secondary fallback. Enable rotating secondary fallback.

5.1.8 Fallback Trigger Registers

The fallback trigger registers are used in conjunction with the fallback type select register and control which H-bus clocks are enabled to trigger a clock fallback event in case of error. The sync reference inputs to DPLL1 and DPLL2 can also trigger a clock fallback event upon detection of an error.

Table 23. Fallback Trigger Registers

Byte Address	Name	Bit(s)	Mnemonic	Value	Function
0x0010A	Fallback Trigger, Lower	7	S2FEB	0 1	Disable /SCLKx2 trigger (default). Enable /SCLKx2 trigger.
		6	SCFEB	0 1	Disable SCLK trigger (default). Enable SCLK trigger.
		5	C2FEB	0 1	Disable C2 trigger (default). Enable C2 trigger.
		4	C4FEB	0 1	Disable /C4 trigger (default). Enable /C4 trigger.
		3	CMFEB	0 1	Disable /C16- trigger (default). Enable /C16- trigger.
		2	CPFEB	0 1	Disable /C16+ trigger (default). Enable /C16+ trigger.
		1	CBFEB	0 1	Disable CT_C8_B trigger (default). Enable CT_C8_B trigger.
		0	CAFEB	0 1	Disable CT_C8_A trigger (default). Enable CT_C8_A trigger.

5 Operating Control and Status (continued)**5.1 Control Registers** (continued)**5.1.8 Fallback Trigger Registers** (continued)**Table 23. Fallback Trigger Registers** (continued)

Byte Address	Name	Bit(s)	Mnemonic	Value	Function
0x0010B	Fallback Trigger, Upper	7	Reserved	0	NOP (default).
		6	D2FEB	0 1	Disable DPLL2 sync trigger (default). Enable DPLL2 sync trigger.
		5	D1FEB	0 1	Disable DPLL1 sync trigger (default). Enable DPLL1 sync trigger.
		4	N2FEB	0 1	Disable CT_NETREF2 trigger (default). Enable CT_NETREF2 trigger.
		3	N1FEB	0 1	Disable CT_NETREF1 trigger (default). Enable CT_NETREF1 trigger.
		2	FCFEB	0 1	Disable /FR_COMP trigger (default). Enable /FR_COMP trigger.
		1	FBFEB	0 1	Disable /CT_FRAME_B trigger (default). Enable /CT_FRAME_B trigger.
		0	FAFEB	0 1	Disable /CT_FRAME_A trigger (default). Enable /CT_FRAME_A trigger.

5.1.9 Watchdog Select, C8, and NETREF Registers

The watchdog select, C8 register controls the watchdog circuits to monitor the proper frequency for the CT_C8_A and CT_C8_B signals. These signals can take on two values, including 8.192 MHz (ECTF mode) and 4.096 MHz (MC1 mode).

The watchdog select, NETREF register controls the watchdog circuits to monitor the proper frequency for the CT_NETREF1 and CT_NETREF2 signals. These signals can take on three values depending on system-level clocking architecture, including 8 kHz (frame reference), 1.544 MHz (T1 bit clock), and 2.048 MHz (E1 bit clock).

Table 24. Watchdog Select, C8, NETREF Registers

Byte Address	Name	Bit(s)	Mnemonic	Value	Function
0x0010C	Watchdog Select, C8	7:4	CBWSN	0000 0001	CT_C8_B watchdog at 8.192 MHz (default). CT_C8_B watchdog at 4.096 MHz MC1mode.
		3:0	CAWSN	0000 0001	CT_C8_A watchdog at 8.192 MHz (default). CT_C8_A watchdog at 4.096 MHz MC1mode.
0x0010D	Watchdog Select, NETREF	7:4	N2WSN	0000 0001 0010	CT_NETREF2 watchdog at 8 kHz (default). CT_NETREF2 watchdog at 1.544 MHz. CT_NETREF2 watchdog at 2.048 MHz.
		3:0	N1WSN	0000 0001 0010	CT_NETREF1 watchdog at 8 kHz (default). CT_NETREF1 watchdog at 1.544 MHz. CT_NETREF1 watchdog at 2.048 MHz.

5 Operating Control and Status (continued)

5.1 Control Registers (continued)

5.1.10 Watchdog EN Register

The watchdog EN registers are used to enable/disable watchdogs on the individual H-bus clocks and the watchdogs on the sync inputs of DPLL1 and DPLL2.

Table 25. Watchdog EN Registers

Byte Address	Name	Bit(s)	Mnemonic	Value	Function
0x0010E	Watchdog EN, Lower	7	S2WEB	0 1	Disable /SCLKx2 watchdog (default). Enable /SCLKx2 watchdog.
		6	SCWEB	0 1	Disable SCLK watchdog (default). Enable SCLK watchdog.
		5	C2WEB	0 1	Disable C2 watchdog (default). Enable C2 watchdog.
		4	C4WEB	0 1	Disable/C4 watchdog (default). Enable/C4 watchdog.
		3	CMWEB	0 1	Disable/C16- watchdog (default). Enable/C16- watchdog.
		2	CPWEB	0 1	Disable/C16+ watchdog (default). Enable/C16+ watchdog.
		1	CBWEB	0 1	Disable CT_C8_B watchdog (default). Enable CT_C8_B watchdog.
		0	CAWEB	0 1	Disable CT_C8_A watchdog (default). Enable CT_C8_A watchdog.
0x0010F	Watchdog EN, Upper	7	FSWEB	0 1	Disable FAILSAFE ref watchdog (default). Enable FAILSAFE ref watchdog.
		6	D2WEB	0 1	Disable DPLL2 sync watchdog (default). Enable DPLL2 sync watchdog.
		5	D1WEB	0 1	Disable DPLL1 sync watchdog (default). Enable DPLL1 sync watchdog.
		4	N2WEB	0 1	Disable CT_NETREF2 watchdog (default). Enable CT_NETREF2 watchdog.
		3	N1WEB	0 1	Disable CT_NETREF1 watchdog (default). Enable CT_NETREF1 watchdog.
		2	FCWEB	0 1	Disable /FR_COMP watchdog (default). Enable /FR_COMP watchdog.
		1	FBWEB	0 1	Disable /CT_FRAME_B watchdog (default). Enable /CT_FRAME_B watchdog.
		0	FAWEB	0 1	Disable /CT_FRAME_A watchdog (default). Enable /CT_FRAME_A watchdog.

5 Operating Control and Status (continued)

5.1 Control Registers (continued)

5.1.11 Failsafe Control Registers

Table 26. Failsafe Control Register

Byte Address	Name	Bit(s)	Mnemonic	Value	Function
0x00114	Failsafe Control	7:0	FSCSR	0000 0000 0000 0001 0000 0010	NOP (default). Return from failsafe to nonfallback condition. Return from failsafe to fallback condition.
0x00115	Failsafe Enable	7:0	FSEER	0000 0000 0000 0001	Failsafe disabled. Failsafe enabled.
0x00116	Failsafe Sensitivity	7:0	FSSSR	0000 0000 0000 0001 0000 0010 0000 0100 0000 1000	Failsafe watchdog highest sensitivity. Failsafe watchdog + 30.5 ns. Failsafe watchdog + 121.0 ns. Failsafe watchdog + 244.0 ns. Failsafe watchdog + 488.0 ns.
0x00118	OOL Threshold Low	7:0	OLLLR	LLLL LLLL	Failsafe threshold value, low byte.
0x00119	OOL Threshold High	7:0	OLHLR	LLLL LLLL	Failsafe threshold value, high byte.
0x0011A	OOL Monitor	7:0	OOLER	0000 0000 0000 0001	Monitor direct APLL1 lock detect at PLOCK. Monitor user threshold lock detect at PLOCK.

The failsafe control register controls a return from the failsafe state. Writes to the failsafe control register trigger the corresponding action, and the set bit(s) are automatically cleared. From the failsafe state, the user can return to either the primary or secondary clock register sets. For more on failsafe, please see Section 6.7.2 on page 70.

The failsafe enable register controls the enable/disable of failsafe operation. For more on failsafe operation, please see Section 6.7.2 on page 70.

The failsafe sensitivity register allows the failsafe watchdog timer to be desensitized by either 1, 4, 8, or 16 watchdog sample clock periods.

The OOL threshold registers allow for programmable threshold times which indicate the APLL1 out-of-lock. Resolution for the threshold value increments is one 32.768 MHz clock period (30.5 ns). The register contains [count – 1], a value of 0x0000 yields a 30.5 ns threshold. A value of 0xFFFF yields a 1.99 ms threshold. For more on OOL operation, please see Section 6.7.2 on page 70.

The OOL monitor register allows the user to monitor either the raw APLL1 out-of-lock status, OR the status flag that indicates that the APLL1 has been out-of-lock for more than the threshold defined in the OOL threshold registers.

5 Operating Control and Status (continued)

5.2 Error and Status Registers

Status 7, 6, and 3—0 registers are writable by the user for clearing specific error bits. Writing a 1 to any of the bits of these registers will clear the corresponding error bit. The remaining error and status registers are read-only.

Table 27. Error and Status Register Map

DWORD Address (20 bits)	Register			
	Byte 3	Byte 2	Byte 1	Byte 0
0x00120	Status 3, latched clock errors, upper	Status 2, latched clock errors, lower	Status 1, transient clock errors, upper	Status 0, transient clock errors, lower
0x00124	Status 7, system errors	Reserved	Reserved	Status 4 fallback and failsafe status
0x00128	Device ID, upper	Device ID, lower	Reserved	Version ID
0x0012C	Reserved	Reserved	Reserved	Reserved

5 Operating Control and Status (continued)**5.2 Error and Status Registers** (continued)**5.2.1 Clock Errors****5.2.1.1 Transient Clock Errors Registers**

The transient clock error registers are used in conjunction with the watchdog EN registers and indicate error status for H-bus clocks and DPLL1/DPLL2 sync inputs whose watchdogs are enabled. The transient indicators are dynamic in nature; if a clock is in error only for a short time and then recovers, the error indication is deasserted when the clock recovers. Additionally, an APLL1 out-of-lock indicator is provided, and used in conjunction with the failsafe clocking mode. For more details, please see Section 6.7.1 on page 64 and Section 6.7.2 on page 70.

Table 28. Clock Error Registers

Byte Address	Name	Bit(s)	Mnemonic	Value	Function
0x00120	Status 0, Transient Clock Errors, Lower	7	S2TOB	0 1	/SCLKx2 no error (default). /SCLKx2 error.
		6	SCTOB	0 1	SCLK no error (default). SCLK error.
		5	C2TOB	0 1	C2 no error (default). C2 error.
		4	C4TOB	0 1	/C4 no error (default). /C4 error.
		3	CMTOB	0 1	/C16– no error (default). /C16– error.
		2	CPTOB	0 1	/C16+ no error (default). /C16+ error.
		1	CBTOB	0 1	CT_C8_B no error (default). CT_C8_B error.
		0	CATOB	0 1	CT_C8_A no error (default). CT_C8_A error.
0x00121	Status 1, Transient Clock Errors, Upper	7	FSTOB	0 1	Failsafe indicator: APLL1 reference no error. APLL1 reference error.
		6	D2TOB	0 1	DPLL2 sync no error (default). DPLL2 sync error.
		5	D1TOB	0 1	DPLL1 sync no error (default). DPLL1 sync error.
		4	N2TOB	0 1	CT_NETREF2 no error (default). CT_NETREF2 error.
		3	N1TOB	0 1	CT_NETREF1 no error (default). CT_NETREF1 error.
		2	FCTOB	0 1	/FR_COMP no error (default). /FR_COMP error.
		1	FBTOB	0 1	/CT_FRAME_B no error (default). /CT_FRAME_B error.
		0	FATOB	0 1	/CT_FRAME_A no error (default). /CT_FRAME_A error.

5 Operating Control and Status (continued)

5.2 Error and Status Registers (continued)

5.2.1 Clock Errors (continued)

5.2.1.2 Latched Clock Error Register

The latched clock error registers capture transient clock errors. The latched indicators capture and hold any transient error status and are used by the clock fallback logic. For more details, see Section 6.7 on page 64, and Section 10 on page 90 for more details.

Table 29. Latched Clock Error Registers

Byte Address	Name	Bit(s)	Mnemonic	Value	Function
0x00122	Status 2, Latched Clock Errors, Lower	7	S2LOB	0 1	/SCLKx2 no error (default). /SCLKx2 error.
		6	SCLOB	0 1	SCLK no error (default). SCLK error.
		5	C2LOB	0 1	C2 no error (default). C2 error.
		4	C4LOB	0 1	/C4 no error (default). /C4 error.
		3	CMLOB	0 1	/C16– no error (default). /C16– error.
		2	CPLOB	0 1	/C16+ no error (default). /C16+ error.
		1	CBLOB	0 1	CT_C8_B no error (default). CT_C8_B error.
		0	CALOB	0 1	CT_C8_A no error (default). CT_C8_A error.
0x00123	Status 3, Latched Clock Errors, Upper	7	FSLOB	0 1	Failsafe indicator: APLL1 reference no error. APLL1 reference error.
		6	D2LOB	0 1	DPLL2 sync no error (default). DPLL2 sync error.
		5	D1LOB	0 1	DPLL1 sync no error (default). DPLL1 sync error.
		4	N2LOB	0 1	CT_NETREF2 no error (default). CT_NETREF2 error.
		3	N1LOB	0 1	CT_NETREF1 no error (default). CT_NETREF1 error.
		2	FCLOB	0 1	/FR_COMP no error (default). /FR_COMP error.
		1	FBLOB	0 1	/CT_FRAME_B no error (default). /CT_FRAME_B error.
		0	FALOB	0 1	/CT_FRAME_A no error (default). /CT_FRAME_A error.

5 Operating Control and Status (continued)

5.2 Error and Status Registers (continued)

5.2.2 System Status

5.2.2.1 Clock Fallback Status Register

The upper nibble provides status indicators for clock fallback. FBFOB indicates whether the circuit is in a clock fallback state. FBSOP indicates which of five possible states the circuit is in; see Section 6.7.1 on page 64 for more details.

The lower nibble provides status indicators related to the X and Y clock register set active/inactive assignments. XYSOB indicates which of the clock register sets is active. The remaining bits indicate a pending status for GO_CLOCKS, CLEAR_FALLBACK, and FORCE_FALLBACK commands issued (via the fallback control register, 0x00108), which are waiting for a frame sync.

Table 30. Fallback and Failsafe Status Register

Byte Address	Register Name	Bit(s)	Mnemonic	Value	Function
0x00124	Status 4, Clock Fallback Status	7	FBFOB	0	Indicates not in fallback/failsafe state (default).
				1	Indicates fallback/failsafe state.
		6:4	FBSOP	111	Fallback state = INITIAL (default).
				000	Fallback state = PRIMARY.
				001	Fallback state = TO_PRIMARY.
				010	Fallback state = SECONDARY.
				011	Fallback state = TO_SECONDARY.
100	Failsafe state = FS_1.				
101	Failsafe state = FS_2.				
3	XYSOB	0	Clock register Y set is active, X is inactive.		
		1	Clock register X set is active, Y is inactive.		
2	GOPOB	0	No GO_CLOCKS pending (default).		
		1	GO_CLOCKS pending, waiting for frame.		
1	CFPOB	0	No CLEAR_FALLBACK pending (default).		
		1	CLEAR_FALLBACK pending, waiting for frame.		
0	FFPOB	0	No FORCE_FALLBACK pending (default).		
		1	FORCE_FALLBACK pending, waiting for frame.		

5 Operating Control and Status (continued)

5.2 Error and Status Registers (continued)

5.2.2 System Status (continued)

5.2.2.2 Device Identification Registers

Table 31. System Errors Registers

Byte Address	Register Name	Bit(s)	Mnemonic	Value	Function
0x00127	Status 7, System Errors	7	CFSOB	0	No error.
				1	Clock failsafe indicator.
		6	CFBOB	0	No error.
1	Clock fallback indicator.				
5:0	Reserved	0	NOP.		

5.2.2.3 System Device Errors

These registers identify the device type and revision status, T8110L revision n.

Table 32. Device Identification Registers

Byte Address	Name	Bit(s)	Mnemonic	Value	Function
0x00128	Version ID	7:0	VEROR	0000 0001	Revision status (value shown = REV1).
0x0012A	Device ID, Lower	7:0	IDLOR	0001 0000	Device ID low status 0x10.
0x0012B	Device ID, Upper	7:0	IDHOR	1000 0001	Device ID high status 0x81.

6 Clock Architecture

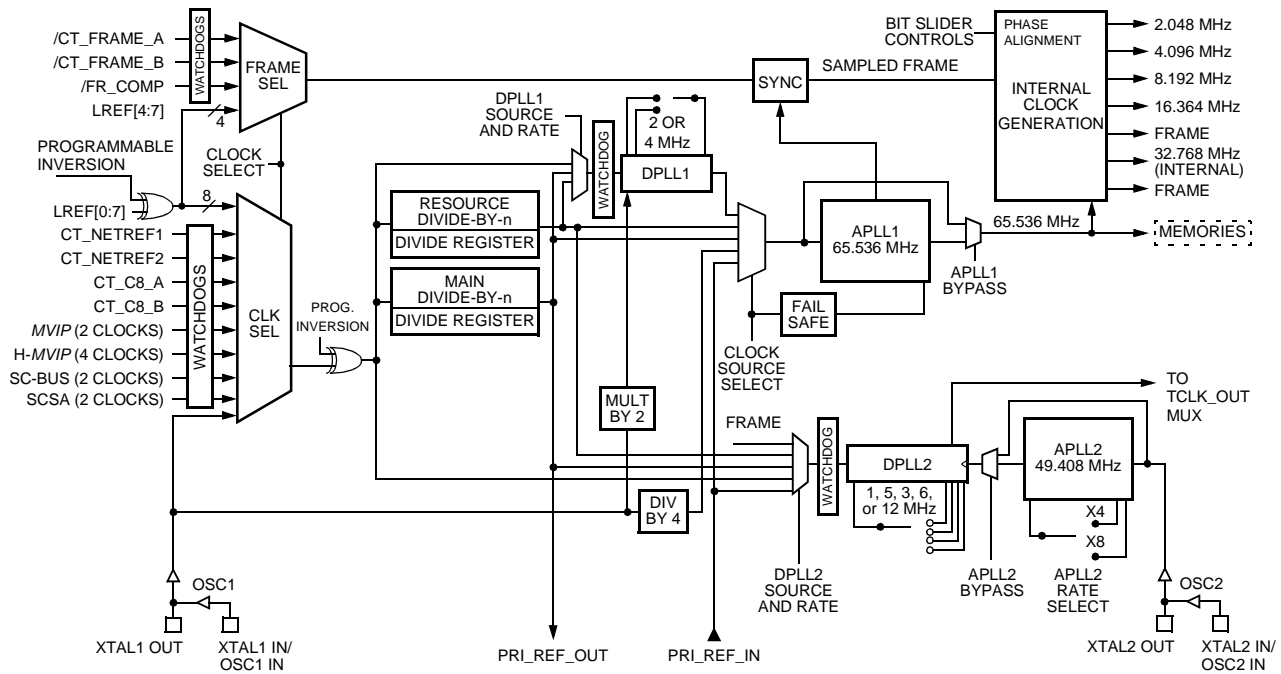

5-9432 (F)

Figure 5. T8110L Main Clocking Paths

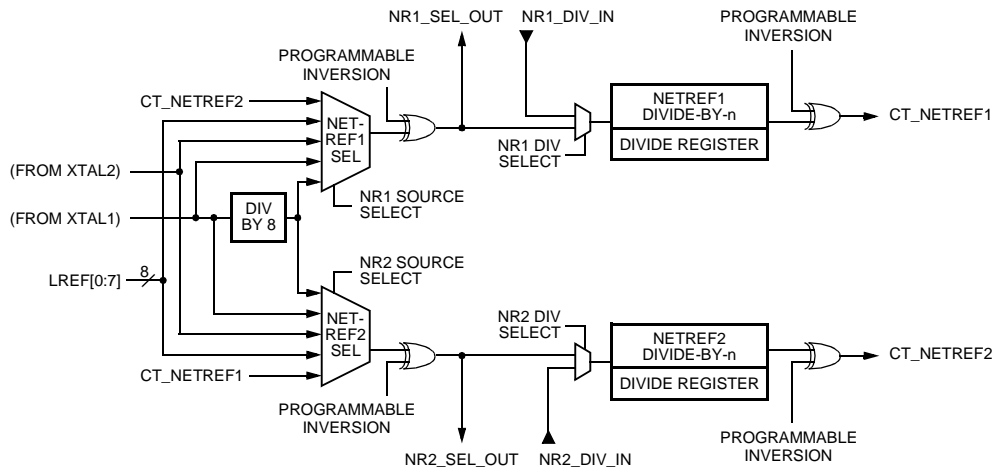

5-9433 (F)

Figure 6. T8110L NETREF Paths

6 Clock Architecture (continued)

6.1 Clock Input Control Registers

The following registers control the T8110L main clocking paths and NETREF paths.

Table 33. Clock Input Control Register Map

DWORD Address (20 Bits)	Register			
	Byte 3	Byte 2	Byte 1	Byte 0
0x00200	APLL1 rate	APLL1 input selector	Main divider	Main input selector
0x00204	APLL2 rate	Reserved	Resource divider	Main inversion select
0x00208	DPLL1 rate	DPLL1 input selector	Reserved	LREF input select
0x0020C	DPLL2 rate	DPLL2 input selector	Reserved	LREF inversion select
0x00210	Reserved	NETREF1 LREF select	NETREF1 divider	NETREF1 input selector
0x00214	Reserved	NETREF2 LREF select	NETREF2 divider	NETREF2 input selector

6.1.1 Main Input Selector Register

The main input selector register controls clock and frame input selection.

Table 34. Main Input Selector Register

Byte Address	Name	Bit(s)	Mnemonic	Value	Function
0x00200	Main Input Selector	7:0	CKMSR	0000 0000 0001 0001 0001 0010 0010 0001 0010 0010 0100 0001 0100 0010 0100 0100 0100 1000 1000 0000 1000 0001 1000 0010 1000 0100 1000 1000	Select oscillator/crystal (default). Select NETREF1. Select NETREF2. Select LREF[0:7] individually. Select LREF[0:3, 4:7] paired. Select H-bus A-clocks. Select H-bus B-clocks. Select MC1 R-clocks. Select MC1 L-clocks. Select <i>MVIP</i> clocks (C2 bit clock)*. Select <i>MVIP</i> clocks (/C4 bit clock). Select H- <i>MVIP</i> clocks (/C16± bit clock). Select SC-bus clocks 2 MHz. Select SC-bus clocks 4/8 MHz.

* C2 is allowed as the bit clock input.

Choices include the following:

Oscillator/crystal clock = XTAL1_IN (16.384 MHz), no frame

NETREF1 clock = CT_NETREF1 (8 kHz, 1.544 MHz, or 2.048 MHz), no frame

NETREF2 clock = CT_NETREF2 (8 kHz, 1.544 MHz, or 2.048 MHz), no frame

LREF individual clock = one of LREF[0:7]*, no frame

LREF paired clock = one of LREF[0:3] (2.048 MHz), frame = one of LREF[4:7]*

H-bus A-clocks clock = CT_C8_A (8.192 MHz), frame = /CT_FRAME_A (8 kHz)

* Selection of which LREF is controlled at register 0x00208. Selection of LREF polarity is controlled at register 0x0020C.

6 Clock Architecture (continued)

6.1 Clock Input Control Registers (continued)

H-bus B-clocks clock = CT_C8_B (8.192 MHz), frame = /CT_FRAME_B (8 kHz)

MC1 R-clocks clock = inverted CT_C8_A (4.096 MHz), frame = /CT_FRAME_A (8 kHz)

MC1 L-clocks clock = inverted CT_C8_B (4.096 MHz), frame = /CT_FRAME_B (8 kHz)

MVIP clocks clock = /C4 (4.096 MHz), frame = /FR_COMP (8 kHz)

MVIP clocks* clock = C2 (2.048 MHz), frame = /FR_COMP (8 kHz)

H-MVIP clocks clock = /C16± (16.384 MHz), frame = /FR_COMP (8 kHz)

SC-BUS 2 MHz clock = /SCLKx2, frame = /FR_COMP (8 kHz)

SC-BUS 4/8 MHz clock = SCLK, frame = /FR_COMP (8 kHz)

* C2 is allowed as the bit clock input.

6.1.2 Main Divider Register

The main divider register contains [divider value – 1]. A value of 0x00 yields a divide-by-1 function. A value of 0xFF yields a divide-by-256 function.

Table 35. Main Divider Register

Byte Address	Name	Bit(s)	Mnemonic	Value	Function
0x00201	Main Divider	7:0	CKMDR	LLLL LLLL	Divider value, {0x00 to 0xFF} = {div1 to div256}, respectively.

6.1.3 Analog PLL1 (APLL1) Input Selector Register

The APLL1 input selector register controls APLL1 reference input selection. The choices include the following:

- APLL1 reference clock = oscillator/4 (4.096 MHz)
- APLL1 reference clock = output of the main divider (4.096 MHz or 2.048 MHz)
- APLL1 reference clock = output of the resource divider (4.096 MHz or 2.048 MHz)
- APLL1 reference clock = output of DPPLL1 (4.096 MHz or 2.048 MHz)
- APLL1 reference clock = input from signal PRI_REF_IN (4.096 MHz or 2.048 MHz)

Table 36. APLL1 Input Selector Register

Byte Address	Name	Bit(s)	Mnemonic	Value	Function
0x00202	APLL1 Input Selector	7:0	P1ISR	0000 0000 0000 0001 0000 0010 0000 0100 0000 1000	Select oscillator/4 (default). Select main divider output. Select resource divider output. Select DPPLL1 output. Select external input PRI_REF_IN.

6 Clock Architecture (continued)

6.1 Clock Input Control Registers (continued)

6.1.4 APLL1 Rate Register

The APLL1 rate register provides the rate multiplier value to APLL1. When APLL1 reference clock is at 4.096 MHz, the [x16 (multiplied by)] value must be selected. When APLL1 reference clock is at 2.048 MHz, the [x32 (multiplied by)] value must be selected. A [x1 (multiplied by)] value is provided in order to bypass APLL1.

Table 37. APLL1 Rate Register

Byte Address	Name	Bit(s)	Mnemonic	Value	Function
0x00203	APLL1 Rate	7:0	P1RSR	0000 0000 0000 0001 0001 xxxx	Times 16 (default). Times 32. Times 1 BYPASS (lower nibble is don't care).

6.1.5 Main Inversion Select Register

The main inversion select register controls programmable inversions at various points within the T8110L main clocking paths and NETREF paths. Internal points allowed for programmable inversion include the following:

- Main clock selection CLK SEL MUX output; see Figure 5 on page 44.
- NETREF2 divider output; see Figure 6 on page 44.
- NETREF2 selection MUX output.
- NETREF1 divider output.
- NETREF1 selection MUX output.

Table 38. Main Inversion Select Register

Byte Address	Name	Bit(s)	Mnemonic	Value	Function
0x00204	Main Inversion Select	7:5	Reserved	000	NOP (default).
		4	ICMSB	0 1	Don't invert main clock selection (default). Invert main clock selection.
		3	N2DSB	0 1	Don't invert NETREF2 divider output (default). Invert NETREF2 divider output.
		2	N2SSB	0 1	Don't invert NETREF2 selection (default). Invert NETREF2 selection.
		1	N1DSB	0 1	Don't invert NETREF1 divider output (default). Invert NETREF1 divider output.
		0	N1SSB	0 1	Don't invert NETREF1 selection (default). Invert NETREF1 selection.

6 Clock Architecture (continued)

6.1 Clock Input Control Registers (continued)

6.1.6 Resource Divider Register

The resource divider register contains [divider value – 1]. A value of 0x00 yields a divide-by-1 function. A value of 0xFF yields a divide-by-256 function.

Table 39. Resource Divider Register

Byte Address	Name	Bit(s)	Mnemonic	Value	Function
0x00205	Resource Divider	7:0	CKRDR	LLLL LLLL	Divider value, {0x00 to 0xFF} = {div1 to div256}, respectively.

6.1.7 Analog PLL2 (APLL2) Rate Register

The APLL2 rate register provides the rate multiplier value to APLL2. When the APLL2 reference clock is at 12.352 MHz, the (times 4) value must be selected. When the APLL2 reference clock is at 6.176 MHz, the (times 8) value must be selected. A (times 1) value is provided in order to bypass APLL2.

Table 40. APLL2 Rate Register

Byte Address	Name	Bit(s)	Mnemonic	Value	Function
0x00207	APLL2 Rate	7:0	P2RSR	0000 0000 0000 0001 0001 xxxx	Times 4 (default). Times 8. Times 1 BYPASS (lower nibble is don't care).

6 Clock Architecture (continued)

6.1 Clock Input Control Registers (continued)

6.1.8 LREF Input Select Registers

The LREF input select register is used in conjunction with the main input selector (0x00200) and provides the selection control among the eight LREF inputs when the main selection is set for either individual or paired LREFs.

The LREF inversion select register allows programmable inversion for each LREF input. Please refer to Section 6.4.1.3 on page 60 for further details.

Table 41. LREF Input/Inversion Select Registers

Byte Address	Name	Bit(s)	Mnemonic	Value	Function		
0x00208	LREF Input Select	7:0	LRISR	0000 0000	Select LREF0 (default).		
				0000 0001	Select LREF0.		
				0000 0010	Select LREF1.		
				0000 0100	Select LREF2.		
				0000 1000	Select LREF3.		
				0001 0000	Select LREF4.		
				0010 0000	Select LREF5.		
				0100 0000	Select LREF6.		
				1000 0000	Select LREF7.		
				0001 0001	Select paired, clock = LREF0, frame = LREF4.		
				0010 0010	Select paired, clock = LREF1, frame = LREF5.		
0100 0100	Select paired, clock = LREF2, frame = LREF6.						
1000 1000	Select paired, clock = LREF3, frame = LREF7.						
0x0020C	LREF Inversion Select	7	IR7SB	0	Don't invert LREF7 (default).		
				1	Invert LREF7.		
				6	IR6SB	0	Don't invert LREF6 (default).
						1	Invert LREF6.
				5	IR5SB	0	Don't invert LREF5 (default).
						1	Invert LREF5.
				4	IR4SB	0	Don't invert LREF4 (default).
						1	Invert LREF4.
3	IR3SB	0	Don't invert LREF3 (default).				
		1	Invert LREF3.				
2	IR2SB	0	Don't invert LREF2 (default).				
		1	Invert LREF2.				
1	IR1SB	0	Don't invert LREF1 (default).				
		1	Invert LREF1.				
0	IR0SB	0	Don't invert LREF0 (default).				
		1	Invert LREF0.				

6 Clock Architecture (continued)

6.1 Clock Input Control Registers (continued)

6.1.9 DPLL1 Input Selector

The DPLL1 input selector selects one of three sources for DPLL1 synchronization input (see Section 6.4.2 on page 61), including the following:

- Main clock selection CLK SEL MUX output
- Main divider output
- Resource divider output

6.1.9.1 DPLL1 Rate Register

The DPLL1 rate register controls the DPLL1 output frequency.

Table 42. DPLL1 Input Selector Registers

Byte Address	Name	Bit(s)	Mnemonic	Value	Function
0x0020A	DPLL1 Input Selector	7:0	D1ISR	0000 0000 0000 0001 0000 0010	Main selector (default). Main divider. Resource divider.
0x0020B	DPLL1 Rate	7:0	D1RSR	0000 0000 0000 0001	DPLL1 output at 4.096 MHz (default). DPLL1 output at 2.048 MHz.

6.1.10 DPLL2 Input Selector

The DPLL2 input selector selects one of five sources for DPLL2 synchronization input (see Section 6.5.1 on page 63), including the following:

- Main clock selection CLK SEL MUX output
- Main divider output
- Resource divider output
- Internal frame
- External input via PRI_REF_IN signal

6 Clock Architecture (continued)

6.1 Clock Input Control Registers (continued)

6.1.10 DPLL2 Input Selector (continued)

6.1.10.1 DPLL2 Rate Register

The DPLL2 rate register controls the DPLL2 output frequency.

Table 43. DPLL2 Register

Byte Address	Name	Bit(s)	Mnemonic	Value	Function
0x0020E	DPLL2 Input Selector	7:0	D2ISR	0000 0000 0000 0001 0000 0010 0000 0100 0000 1000	Main selector (default). Main divider. Resource divider. T8110L internally generated frame. External input PRI_REF_IN.
0x0020F	DPLL2 Rate	7:0	D2RSR	0000 0000 0000 0001 0000 0010 0000 0100 0000 1000	DPLL2 output off (default). DPLL2 output at 1.544 MHz. DPLL2 output at 3.088 MHz. DPLL2 output at 6.176 MHz. DPLL2 output at 12.352 MHz.

6.1.11 NETREF1 Registers

The NETREF1 input selector, NETREF1 divider, and NETREF1 LREF select registers control the signal paths used to generate CT_NETREF1 (see Figure 6 on page 44).

Table 44. NETREF1 Registers

Byte Address	Name	Bit(s)	Mnemonic	Value	Function
0x00210	NETREF1 Input Selector	7:4	N1DSN	0000 0001	Divider input = selector output (default). Divider input = external input NR1_DIV_IN.
		3:0	N1ISN	0000 0001 0010 0100 1000	Oscillator/XTAL1-div-8, 2.048 MHz (default). Oscillator/XTAL1, 16.384 MHz. CT_NETREF2 input. LREF input*. Oscillator/XTAL2, 6.176 MHz, or 12.352 MHz.
0x00211	NETREF1 Divider	7:0	NR1DR	LLLL LLLL	Divider value, {0x00 to 0xFF} = {div1 to div256}, respectively.
0x00212	NETREF1 LREF Select	7:0	N1LSR	0000 0000 0000 0001 0000 0010 0000 0100 0000 1000 0001 0000 0010 0000 0100 0000 1000 0000	Select LREF0 (default). Select LREF0. Select LREF1. Select LREF2. Select LREF3. Select LREF4. Select LREF5. Select LREF6. Select LREF7.

* Selection of which LREF is controlled at register 0x00212.

6 Clock Architecture (continued)

6.1 Clock Input Control Registers (continued)

6.1.12 NETREF2 Registers

The NETREF2 input selector, NETREF2 divider, and NETREF2 LREF select registers control the signal paths used to generate CT_NETREF2 (see Figure 6 on page 44).

Table 45. NETREF2 Registers

Byte Address	Name	Bit(s)	Mnemonic	Value	Function
0x00214	NETREF2 Input Selector	7:4	N2DSN	0000 0001	Divider input = selector output (default). Divider input = external input NR1_DIV_IN.
		3:0	N2ISN	0000 0001 0010 0100 1000	Oscillator/XTAL1-div-8, 2.048 MHz (default). Oscillator/XTAL1, 16.384 MHz. CT_NETREF1 input. LREF input*. Oscillator/XTAL2, 6.176 MHz, or 12.352 MHz.
0x00215	NETREF2 Divider	7:0	NR2DR	LLLL LLLL	Divider value, {0x00 to 0xFF} = {div1 to div256}, respectively.
0x00216	NETREF2 LREF Select	7:0	N2LSR	0000 0000 0000 0001 0000 0010 0000 0100 0000 1000 0001 0000 0010 0000 0100 0000 1000 0000	Select LREF0 (default). Select LREF0. Select LREF1. Select LREF2. Select LREF3. Select LREF4. Select LREF5. Select LREF6. Select LREF7.

* Selection of which LREF is controlled at register 0x00216.

6 Clock Architecture (continued)

6.2 Clock Output Control Registers

The registers listed below control output enable and rate selection of the T8110L clock path outputs.

Table 46. Clock Output Control Register Map

DWORD Address (20 Bits)	Register			
	Byte 3	Byte 2	Byte 1	Byte 0
0x00220	C8 output rate	/FR_COMP width	NETREF output enables	Master output enables
0x00224	SCLK output rate	TCLK select	Reserved	CCLK output enables
0x00228	L_SC3 select	L_SC2 select	L_SC1 select	L_SC0 select

6.2.1 Master Output Enables Register

The master output enables register controls the output enables for H-bus and compatibility clocks (CCLK) for T8110L clock mastering. A-clocks refers to the combination of CT_C8_A bit clock and /CT_FRAME_A frame reference.

B-clocks refers to the CT_C8_B bit clock and /CT_FRAME_B frame reference.

These programmable enables are used in conjunction with master enable register 0x00103, H-bus clock enables, HCKEB.

The NETREF output enables register controls the output enables for CT_NETREF1 and CT_NETREF2. These programmable enables are used in conjunction with master enable register 0x00103, H-bus clock enables, HCKEB.

The CCLK output enables register is used in conjunction with register 0x00220 and controls the output enables for various groupings of compatibility clocks, including the following:

- H-MVIP bit clock only(/C16±)
- MVIP clocks (/C4, C2)
- H-MVIP clocks (/C16±, /C4, C2)
- SC-bus clocks (SCLK, /SCLKx2)
- /FR_COMP compatibility frame reference

6 Clock Architecture (continued)

6.2 Clock Output Control Registers (continued)

6.2.1 Master Output Enables Register (continued)

Table 47. Master Output Enables Registers

Byte Address	Name	Bit(s)	Mnemonic	Value	Function
0x00220	Master Output Enables	7:4	ABOEN	0000 0001 0010 0011	Disable A and B clock outputs (default). Enable A clock outputs only. Enable B clock outputs only. Enable both A and B clock outputs.
		3:0	CCOEN	0000 0001 0010	Disable compatibility (C clock) outputs (default). Enable C clocks individually*. Enable all C clocks.
0x00221	NETREF Output Enables	7:4	N2OEN	0000 0001	CT_NETREF2 disabled (default). CT_NETREF2 enabled.
		3:0	N1OEN	0000 0001	CT_NETREF1 disabled (default). CT_NETREF1 enabled.
0x00224	CCLK Output Enables	7:4	FRSEN	0000 0001	/FR_COMP disabled (default). /FR_COMP enabled.
		3:0	CCSEN	0000 0001 0010 0011 0100	C-clock bit clocks disabled (default). Enable H-MVIP bit clock. Enable MVIP clocks. Enable H-MVIP all clocks. Enable SC-bus clocks.

* Overall selection includes all C clocks OFF, all C clocks ON, or select individual groups of C clocks to be enabled, in conjunction with register 0x00224.

6.2.2 Clock Output Format Registers

The clock output format registers select the pulse width of the /FR_COMP pulse width.

Note: When the T8110L is slowing to a compatibility bus, the /FR_COMP signal must be 122 ns. The T8110L cannot phase align to a 244 ns /FR_COMP signal.

The C8 output rate register selects the CT_C8_A and CT_C8_B clock output frequency 8.192 MHz for ECTF (H1x0) mode, or 4.096 MHz for MC1 mode.

The SCLK output rate register selects between three SC-Bus clock configurations, including the following:

- SCLK = 2.048 MHz, /SCLKx2 = 4.096 MHz
- SCLK = 4.096 MHz, /SCLKx2 = 8.192 MHz
- SCLK = 8.192 MHz, /SCLKx2 = 8.192 MHz (phase shifted from SCLK)

6 Clock Architecture (continued)

6.2 Clock Output Control Registers (continued)

6.2.2 Clock Output Format Registers (continued)

Table 48. Clock Output Format Registers

Byte Address	Name	Bit(s)	Mnemonic	Value	Function
0x00222	/FR_COMP Width	7:0	FRWSR	0000 0000 0000 0001	/FR_COMP width is 122 ns (default). /FR_COMP width is 244 ns.
0x00223	C8 Output Rate	7:4	BCRSN	0000 0001	CT_C8_B output at 8.192 MHz (default). CT_C8_B output at 4.096 MHz, MC1 mode.
		3:0	ACRSN	0000 0001	CT_C8_A output at 8.192 MHz (default). CT_C8_A output at 4.096 MHz, MC1 mode.
0x00227	SCLK Output Rate	7:0	SCRSR	0000 0000 0000 0001 0000 0010	SCLK = 2 MHz, /SCLKx2 = 4 MHz (default). SCLK = 4 MHz, /SCLKx2 = 8 MHz. SCLK = 8 MHz, /SCLKx2 = 8 MHz phase shifted.

6.2.3 TCLK and L_SCx Select Registers

The TCLK select register controls the selection of various internally generated clocks for output to the TCLK_OUT signal.

The L_SCx select registers control the selection of various internally generated clocks for output to the L_SC0, L_SC1, L_SC2, and L_SC3 signals.

6 Clock Architecture (continued)

6.2 Clock Output Control Registers (continued)

6.2.3 TCLK and L_SCx Select Registers (continued)

Table 49. TCLK Select and L_SCx Select Registers

Byte Address	Name	Bit(s)	Mnemonic	Value	Function
0x00226	TCLK Select	7:0	TCOSR	0000 0000 0000 0001 0000 0010 0001 0001 0001 0010 0010 0000 0010 0001 0010 0010 0011 0000 0011 0001 0011 0010 0100 0000 0100 0001 0100 0010 0100 0100 0100 1000 0101 0000 0101 0001 0101 0010 0101 0100 0101 1000 1000 0000 1000 0001 1000 0010 1001 0000 1001 0001 1001 0010	TCLK output disabled (default). Select OSC1/XTAL1. Select OSC2/XTAL2. Select OSC1/XTAL1 inverted. Select OSC2/XTAL2 inverted. Select DPLL2 output. Select APLL1 output, 65.536 MHz. Select APLL2 output, 49.704 MHz. Select DPLL2 output inverted. Select APLL1 output inverted. Select APLL2 output inverted. Select generated 2.048 MHz. Select generated 4.096 MHz. Select generated 8.192 MHz. Select generated 16.384 MHz. Select generated 32.768 MHz. Select generated 2.048 MHz inverted. Select generated 4.096 MHz inverted. Select generated 8.192 MHz inverted. Select generated 16.384 MHz inverted. select generated 32.768 MHz inverted. Select generated frame. Select generated CT_NETREF1. Select generated CT_NETREF2. Select generated frame inverted. Select generated CT_NETREF1 inverted. Select generated CT_NETREF2 inverted.
0x00228 (0x00229) (0x0022A) (0x0022B)	L_SC0 Select L_SC1 Select L_SC2 Select L_SC3 Select	7:0	LC0SR (LC1SR) (LC2SR) (LC3SR)	0000 0000 0000 0001 0001 0001 0100 0000 0100 0001 0100 0010 0100 0100 0100 1000 0101 0000 0101 0001 0101 0010 0101 0100 0101 1000 1000 0000 1000 0001 1000 0010 1001 0000 1001 0001 1001 0010	L_SCx output disabled (default). Select OSC1/XTAL1. Select OSC1/XTAL1 inverted. Select generated 2.048 MHz. Select generated 4.096 MHz. Select generated 8.192 MHz. Select generated 16.384 MHz. Select generated 32.768 MHz. Select generated 2.048 MHz inverted. Select generated 4.096 MHz inverted. Select generated 8.192 MHz inverted. Select generated 16.384 MHz inverted. Select generated 32.768 MHz inverted. Select generated frame. Select generated CT_NETREF1. Select generated CT_NETREF2. Select generated frame inverted. Select generated CT_NETREF1 inverted. Select generated CT_NETREF2 inverted.

6 Clock Architecture (continued)

6.3 Clock Register Access

The T8110L clock control registers, 0x00200—0x002FF, consist of two identical sets of registers, X and Y. At any given time, only one set is actually controlling the clocking (denoted as the active set), while the other is in a standby state (inactive set). Either set, X or Y, may be the active set, as determined by a state machine that tracks the clock fallback control and status and assigns either set to be active accordingly. For more details, see Section 6.7.1 on page 64. Users may only access one register set at a time. By default, access is allowed to the current inactive set, but access to the active set is allowed via the clock register access select register, 0x00106; see Section 5.1.4 on page 33.

6.4 Clock Circuit Operation—APLL1

APLL1 can accept either a 4.096 MHz or 2.048 MHz reference clock, and perform a corresponding multiplication function to supply a 65.536 MHz operating clock for the T8110L. Additionally, APLL1 may be bypassed for circuit diagnostic purposes. Please refer to Figure 5 on page 44.

6.4.1 Main Clock Selection, Bit Clock, and Frame

APLL1 clock references are selectable as stand-alone bit clocks, frames, or a pairing of bit clock and frame (see main input selector register, 0x00200). The bit clock output of the main clock selection is available as input to the main divider, resource divider, and DPLL1.

Table 50. Bit Clock and Frame

Bit Clock	Corresponding 8 kHz Frame	Value(s)
CT_NETREF1, CT_NETREF2	—	1.544 MHz (T1), 2.048 MHz (E1)
NA	CT_NETREF1, CT_NETREF2	8 kHz
CT_C8_A	/CT_FRAME_A	8.192 MHz (ECTF), 4.096 MHz (MC1)
CT_C8_B	/CT_FRAME_B	8.192 MHz (ECTF), 4.096 MHz (MC1)
/C16±	/FR_COMP	16.384 MHz (H-MVIP)
/C4	/FR_COMP	4.096 MHz (MVIP)
C2	/FR_COMP	2.048 MHz (MVIP*)
SCLK	/FR_COMP	2.048 MHz, 4.096 MHz, 8.192 MHz (SC-bus)
/SCLKx2	/FR_COMP	4.096 MHz, 8.192 MHz (SC-bus)
LREF[0]	LREF[4]†	System-specific
LREF[1]	LREF[5]†	System-specific
LREF[2]	LREF[6]†	System-specific
LREF[3]	LREF[7]†	System-specific
LREF[4]	—	System-specific
LREF[5]	—	System-specific
LREF[6]	—	System-specific
LREF[7]	—	System-specific

* MVIP, /C4 is typically the bit clock. C2 is selectable as the bit clock as well.

† Used when LREF pairing is enabled. When using LREF pairing, the bit clock should be 2.048 MHz.

6 Clock Architecture (continued)

6.4 Clock Circuit Operation—APLL1 (continued)

6.4.1 Main Clock Selection, Bit Clock, and Frame (continued)

6.4.1.1 Watchdog Timers

A set of watchdog timers is available for all H1x0, H-MVIP, MVIP, and SC-bus clocks. No watchdogs are available for LREF[7:0] directly; however, the LREF inputs may be monitored indirectly via watchdogs on the DPLL1 and DPLL2 sync inputs, or via the failsafe mechanism; see Section 6.7.2 on page 70. The watchdogs sample the incoming clocks at 32.768 MHz (derived from the XTAL1 crystal) and monitor for loss of signal, as shown below.

Table 51. Watchdog Timer Description

Watchdog	Signal, Value	Description
H1x0 clock monitors*	CT_C8_A at 8.192 MHz CT_C8_B at 8.192 MHz	ECTF mode. Checks for CT_C8 rising edge within a 35 ns window of its expected arrival.
	CT_C8_A at 4.096 MHz CT_C8_B at 4.096 MHz	MC1 mode. Monitors for loss of signal (falling edges).
FRAME monitors	/CT_FRAME_A /CT_FRAME_B /FR_COMP	Monitors for 8 kHz frequency. Detects frame overflow (i.e., next frame pulse too late) and frame underflow (i.e., next frame pulse too early).
NETREF monitors*	CT_NETREF1 at 1.544 MHz CT_NETREF2 at 1.544 MHz	NETREF is T1 bit clock. Monitors for loss of signal (rising or falling edges).
	CT_NETREF1 at 2.048 MHz CT_NETREF2 at 2.048 MHz	NETREF is E1 bit clock. Monitors for loss of signal (rising or falling edges).
	CT_NETREF1 at 8 kHz CT_NETREF2 at 8 kHz	NETREF is 8 kHz frame reference. Monitors for 8 kHz frequency. Detects frame overflow (i.e., next frame pulse too late) and frame underflow (i.e., next frame pulse too early).
Compatibility clock monitors	/C16± at 16.384 MHz /C4 at 4.096 MHz C2 at 2.048 MHz SCLK, /SCLKx2 at any of their defined values.	Gross loss-of-signal detector—clocks are sampled and normalized to 1.024 MHz. It can take up to 976 ns for these watchdog timers to detect loss of a compatibility clock.
DPLL1, DPLL2 sync monitors †	Output of MUX selector to the SYNC input of each DPLL (8 kHz)	Monitors for 8 kHz frequency. Detects frame overflow (i.e., next frame pulse too late) and frame underflow (i.e., next frame pulse too early).

* User selects frequency at which to monitor the CT_C8 clocks via register 0x0010C, watchdog select, C8.

† DPLL sync reference is expected to be 8 kHz.

6 Clock Architecture (continued)

6.4 Clock Circuit Operation—APLL1 (continued)

6.4.1 Main Clock Selection, Bit Clock, and Frame (continued)

6.4.1.2 Frame Center Sampling

Frame center samples are used in order to phase-align the incoming frame reference to the internally generated frame reference; see Section 6.4.5.1 on page 62. The incoming frame reference signal is sampled with a recovered clock (output of the APLL1 feedback divider) to determine the frame center. Frame center sampling is only relevant when the main clock selection is based on a paired bit clock/frame reference, as follows.

Table 52. Frame Center Sampling

Frame Signal	Corresponding Bit Clock	Sample Clock
/CT_FRAME_A	CT_C8_A	Recovered 8.192 MHz, rising edge.
/CT_FRAME_B	CT_C8_B	Recovered 8.192 MHz, rising edge.
/FR_COMP	/C16± (H-MVIP) or /C4 (MVIP) or C2 (MVIP)	Recovered 4.096 MHz, falling edge.
/FR_COMP	SCLK or /SCLKx2 (SC-bus)	Recovered 2.048 MHz, rising edge.
LREF[4]	LREF[0]	Recovered 2.048 MHz, rising edge.
LREF[5]	LREF[1]	Recovered 2.048 MHz, rising edge.
LREF[6]	LREF[2]	Recovered 2.048 MHz, rising edge.
LREF[7]	LREF[3]	Recovered 2.048 MHz, rising edge.

6 Clock Architecture (continued)

6.4 Clock Circuit Operation—APLL1 (continued)

6.4.1 Main Clock Selection, Bit Clock, and Frame (continued)

6.4.1.3 LREF Pair Polarity Configuration

The T8110L may derive its clocking from an LREF pair, which is comprised of a frame pulse and a 2.048 MHz bit clock. In order to achieve proper phase alignment when deriving clocking from LREF pairs, the T8110L must be provided with a frame pulse and bit clock with polarities as shown below.

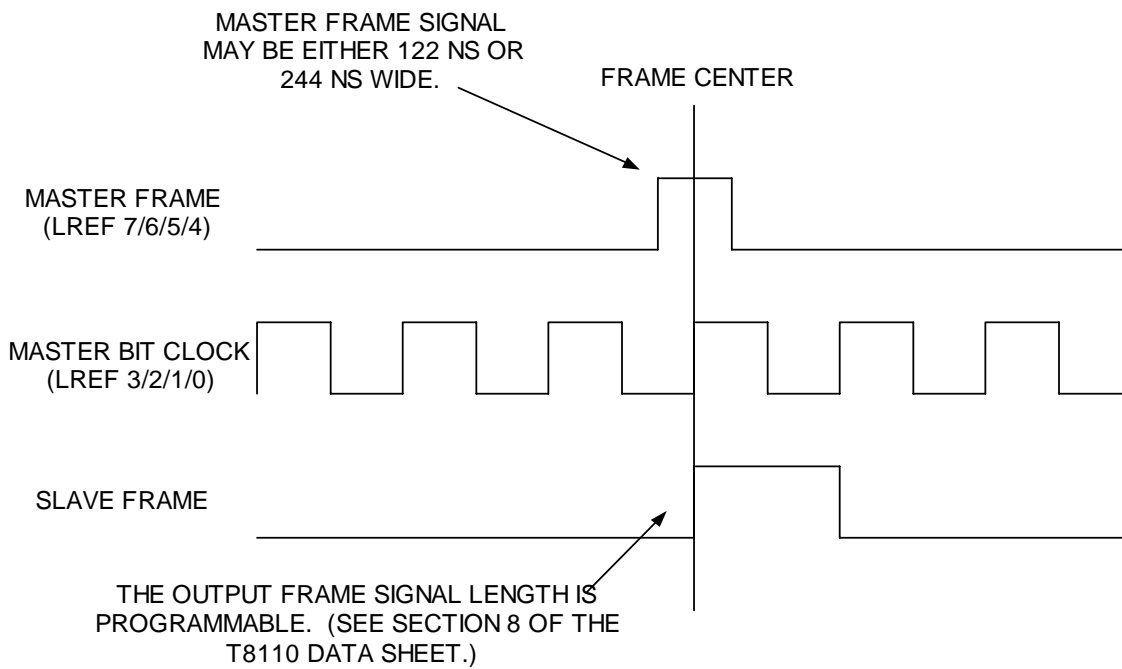

Figure 7. T8110L Required Frame Pulse and Bit Clock with Polarities

If the frame pulse and bit clock cannot be externally provided with the proper polarities, the polarities can be internally adjusted via the main inversion select register (0x204) and the LREF inversion select register (0x20C). The main inversion select register will allow inversion of only the bit clock, while the LREF inversion select register allows any LREF signal to be inverted.

Note: Once the frame pulse and bit clock polarity have been properly configured, they must not be changed while the T8110L is deriving clocking from the LREF pair.

6 Clock Architecture (continued)

6.4 Clock Circuit Operation—APLL1 (continued)

6.4.2 Main and Resource Dividers

Two independently programmable dividers are available to divide down the main clock selection signal. The function ranges from divide-by-1 (bypass) to divide-by-256.

- For binary divider values of 1, 2, 4, 8, 16, 32, 64, 128, and 256, the output is 50% duty cycle.
- For a divider value of 193, the output is almost 50% duty cycle (low-level duration is one clock cycle shorter than high-level duration).
- For **all** other divider values, the output is a pulse whose width is one full period of the main clock selection signal.

Output of both dividers is available to the DPLL1 and the APLL1 reference selector. The output of the main divider is also available at the PRI_REF_OUT chip output.

Both dividers are reset whenever a changeover between X and Y clock register sets is detected; see Section 6.3 on page 57. This allows for immediate loading of the newly activated divider register values.

6.4.3 DPLL1

A digital phase-lock loop is provided to generate a 4.096 MHz or 2.048 MHz reference to APLL1, selectable via register 0x0020B (DPLL1 rate). The DPLL1 operates at 32.768 MHz, derived from the XTAL1 crystal input. The DPLL1 synchronization source is selectable (register 0x0020A, DPLL1 input selector) between the main clock selection signal, the output of the resource divider, or the output of the main divider, and is intended to be presented as an 8 kHz frame reference. DPLL1 is determined to be in-lock or out-of-lock, based on the state of the output clock when an edge transition is detected at the synchronization source. An out-of-lock condition results in a DPLL1 correction, which can either lengthen or shorten its current output clock period by 30.5 ns.

6.4.4 Reference Selector

The APLL1 reference clock is selectable between five possible sources via register 0x00202, APLL1 input selector. A 4.096 MHz or 2.048 MHz reference must be provided. The five possible sources are shown below:

- XTAL1 crystal (16.384 MHz) divided-by-4
- Main divider output
- Resource divider output
- DPLL1 output
- PRI_REF_IN external chip input

6.4.5 Internal Clock Generation

The main internal functions of T8110L are synchronous to the 65.536 MHz output of APLL1. This clock is further divided to generate 32.768 MHz, 16.384 MHz, and 8 kHz internal reference signals. Additional divide-down values to 8.192 MHz, 4.096 MHz, and 2.048 MHz are generated. These generated clocks are the source for H1x0, H-MVIP, MVIP, and SC-bus clocks when the T8110L is mastering the bus clocks; see Section 6.2 on page 53. These internally generated clocks can either be free-running, or can be aligned to the incoming main selection clock and frame, via a phase alignment circuit (see Section 7.4.5.1).

6 Clock Architecture (continued)

6.4 Clock Circuit Operation—APLL1 (continued)

6.4.5 Internal Clock Generation (continued)

6.4.5.1 Phase Alignment

Phase alignment allows the free-running internally generated clocks to be forced into alignment with the incoming main selection clock and frame, under the following conditions:

- The main selection clock is based on a paired bit clock/frame reference (see Section 6.4.1.2 on page 59), **and** the phase alignment circuit is enabled (via register 0x00107, phase alignment select).

The incoming frame center is monitored via the frame center samplers (see Section 6.4.1.2 on page 59) and compared to the state of the internally generated frame. The circuit determines whether the frame centers are aligned. If not, three possible actions take place as shown below:

- NOP: no corrections when phase alignment is disabled.
- Snap correction: the internally generated clocks and frame immediately snap into alignment with the incoming frame center.
- Slide correction: the internally generated clocks and frame gradually slide into alignment with the incoming frame center, at a rate of one 65.536 MHz clock period per frame. The sliding occurs in one direction only and creates frame periods that are 15.25 ns longer than 125 μ s until the frames are aligned. Please refer to Figure 8.

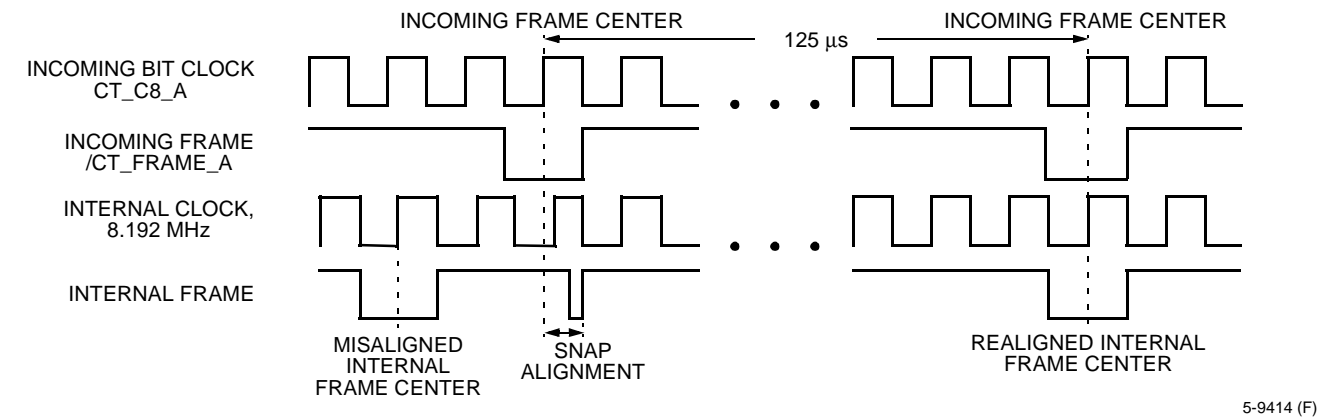

A. Phase Alignment—SNAP

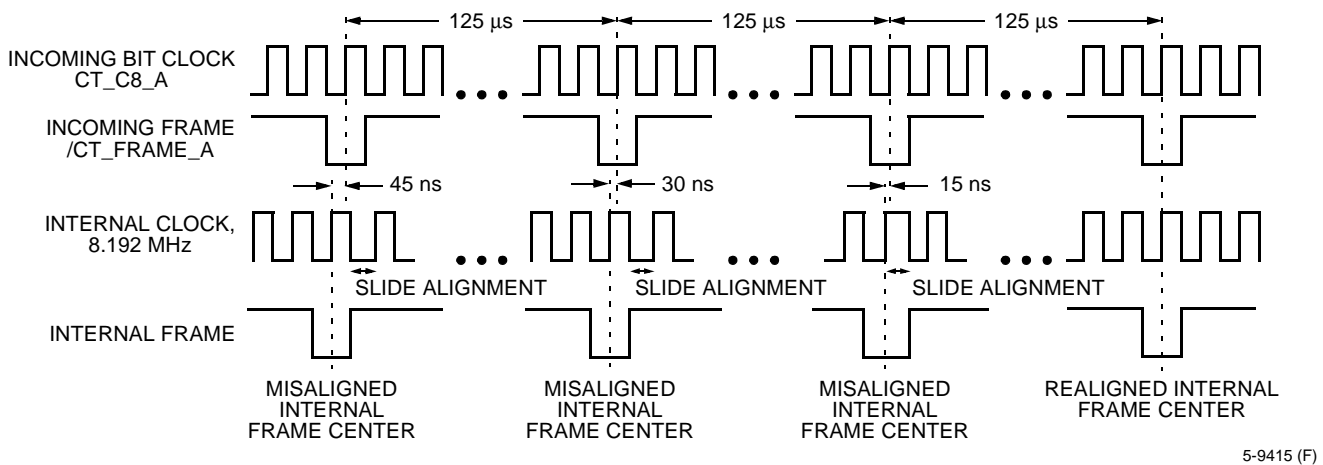

B. Phase Alignment—SLIDE

Figure 8. T8110L Phase Alignment, SNAP and SLIDE

6 Clock Architecture (continued)

6.5 Clock Circuit Operation, APLL2

APLL2 requires either a 6.176 MHz or 12.352 MHz reference clock to produce a 49.408 MHz clock for operating DPPLL2. A user-supplied rate multiplier (register 0x00207, APLL2 rate) provides either a times 8 function (when reference clock = 6.176 MHz) or a times 4 function (when reference clock = 12.352 MHz). Additionally, APLL2 may be bypassed for circuit diagnostic purposes (see Figure 5 on page 44).

6.5.1 DPPLL2

A second digital phase-lock loop is provided to generate various derivations of T1 operating frequencies, available by selection via the TCLK_OUT output. The possible output frequencies are selectable via register 0x0020F (DPPLL2 rate) and include 1.544 MHz, 3.088 MHz, 6.176 MHz, and 12.352 MHz. The DPPLL2 input clock operates at 49.408 MHz from the APLL2 output. Synchronization sources for DPPLL2 include the same sources provided to DPPLL1 (selectable between the main clock selection signal, the output of the resource divider, or the output of the main divider) and two additional sources, including the T8110L internally generated frame signal and the PRI_REF_IN input. These selections are available via register 0x0020E, DPPLL2 input selector. DPPLL2 is determined to be in-lock or out-of-lock based on the state of its output when an edge transition is detected at the synchronization source. An out-of-lock condition results in a DPPLL2 correction, which can either lengthen or shorten its current output clock period by 20.2 ns.

6.6 Clock Circuit Operation, CT_NETREF Generation

The T8110L provides two independently programmable paths to generate CT_NETREF1 and CT_NETREF2, via registers 0x00210—0x00216. Each CT_NETREF is individually enabled with register 0x00221, NETREF output enables. Each path consists of a source selector MUX and a divider circuit (see Figure 6 on page 44).

6.6.1 NETREF Source Select

XTAL1 input DIV 8 (2.048 MHz)

XTAL1 input (16.384 MHz)

XTAL2 input (6.176 MHz or 12.352 MHz)

LREF[7:0]

CT_NETREF_x (the other NETREF—i.e., CT_NETREF1 can be derived from CT_NETREF2, and vice-versa).

The output of the source select MUX is made available directly to the NETREF divider, and also to chip output (NR1_SEL_OUT, NR2_SEL_OUT).

6.6.2 NETREF Divider

Each NETREF path provides a divider from a divide-by-1 function up to a divide-by-256 function. The clock source for the divider is selectable between the output of the source select MUX or from external chip input (NR1_DIV_IN, NR2_DIV_IN).

- For binary divider values of 1, 2, 4, 8, 16, 32, 64, and 128, output is 50% duty cycle.
- For divider values of 256, 193, plus all other nonbinary values, output is a pulse whose width is one-half of a clock period, asserted during the second half of the divider clock period.

The NETREF dividers are reset whenever a changeover between **X** and **Y** clock register sets is detected (see Section 6.3 on page 57). This allows for immediate loading of the newly activated divider register values.

6 Clock Architecture (continued)

6.7 Clock Circuit Operation—Fallback and Failsafe

Fallback is a means to alter the reference source to APLL1 by switching between two clock control register sets upon detection of a fallback event. Failsafe is a feature to provide a safety net for the reference source to APLL1, independent of clock fallback.

6.7.1 Clock Fallback

Clock fallback is a means to alter the APLL1 reference clock source upon detection of a fallback event and is controlled by eight registers, 0x00108—0x0010F (refer to Section 5.1.4 on page 33). These registers enable and control the state transitions that determine which of two clock register sets is used to control the APLL1 reference clock source (see Section 6.1 on page 45 through Section 6.3, Table 54 on page 67, and Figure 10 on page 66).

6.7.1.1 Fallback Events

Clock fallback (transition from primary to secondary clock sets) can only occur if the fallback mode is enabled (register 0x00109, lower nibble) and a fallback event occurs. When enabled, there are three ways to trigger the fallback event:

- Software, via a FORCE_FALLBACK command. The user sets bit 2 of the fallback control register, 0x00108, creating a software-invoked fallback event.
- Hardware via the fallback trigger enable registers, 0x0010A—0x0010B. User may enable specific watchdog timers and corresponding fallback trigger enable bits. If a watchdog timer indicates a clock error, and its corresponding trigger enable bit is set, a hardware-invoked fallback event is produced.
- Hardware, legacy modes, via the fallback type select register, 0x00109, upper nibble. The legacy modes are included to maintain backwards compatibility with earlier *Ambassador* devices. User may enable specific watchdog timers, but the fallback trigger enable registers are ignored. Instead, the watchdogs which are allowed to trigger a fallback event are automatically selected based on the state of the main input selector register, 0x00200 (refer to Table 53). If a watchdog timer indicates a clock error, and its corresponding trigger enable is selected via the main input selector, a hardware-invoked fallback event is produced.

6 Clock Architecture (continued)

6.7 Clock Circuit Operation—Fallback and Failsafe (continued)

6.7.1 Clock Fallback (continued)

6.7.1.1 Fallback Events (continued)

Table 53. Legacy Mode Fallback Event Triggers

Main Input Selector Function (Register 0x00200)	Selected Watchdog Triggers (Legacy Modes)
Oscillator/crystal	None
CT_NETREF1	NETREF1 watchdog
CT_NETREF	NETREF2 watchdog
LREF, individual	None
LREF, paired	None
H-bus, A clocks	CT_C8_A and /CT_FRAME_A watchdogs
H-bus, B clocks	CT_C8_B and /CT_FRAME_B watchdogs
MC1, R clocks	None
MC1, L clocks	None
MVIP clocks (/C4 or C2 bit clock)	/C4, C2, and /FR_COMP watchdogs
H-MVIP clocks	/C16±, /C4, C2, and /FR_COMP watchdogs
SC-bus clocks (2 MHz or 4/8 MHz)	SCLK, /SCLKx2, and /FR_COMP watchdogs

6.7.1.2 Fallback Scenarios—Fixed vs. Rotating Secondary

When clock fallback is enabled (register 0x00109, lower nibble), there are two possible scenarios for transitioning between the primary and secondary clock sets.

In a fixed secondary scheme, a fallback event switches the active clock set from primary to secondary. When the fallback event is cleared (via user-invoked CLEAR_FALLBACK), the active clock set returns to primary.

In a rotating secondary scheme, a fallback event switches the active clock set from primary to secondary. When the fallback event is cleared, the secondary remains as the new active clock set. In effect, the secondary becomes the new primary, and the primary becomes the new secondary.

The concepts are illustrated in the figure below.

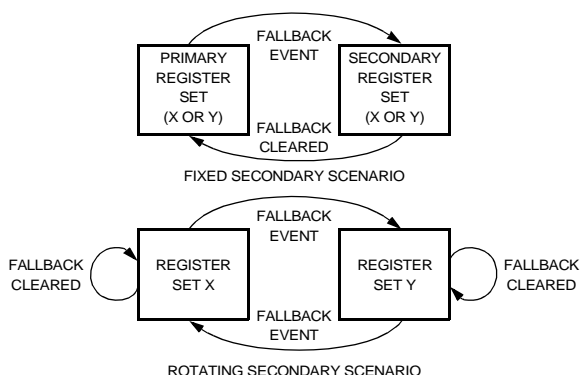

5-9420 (F)

Figure 9. Fallback—Fixed vs. Rotating Secondary

6 Clock Architecture (continued)

6.7 Clock Circuit Operation—Fallback and Failsafe (continued)

6.7.1 Clock Fallback (continued)

6.7.1.1 Fallback Scenarios—Fixed vs. Rotating Secondary (continued)

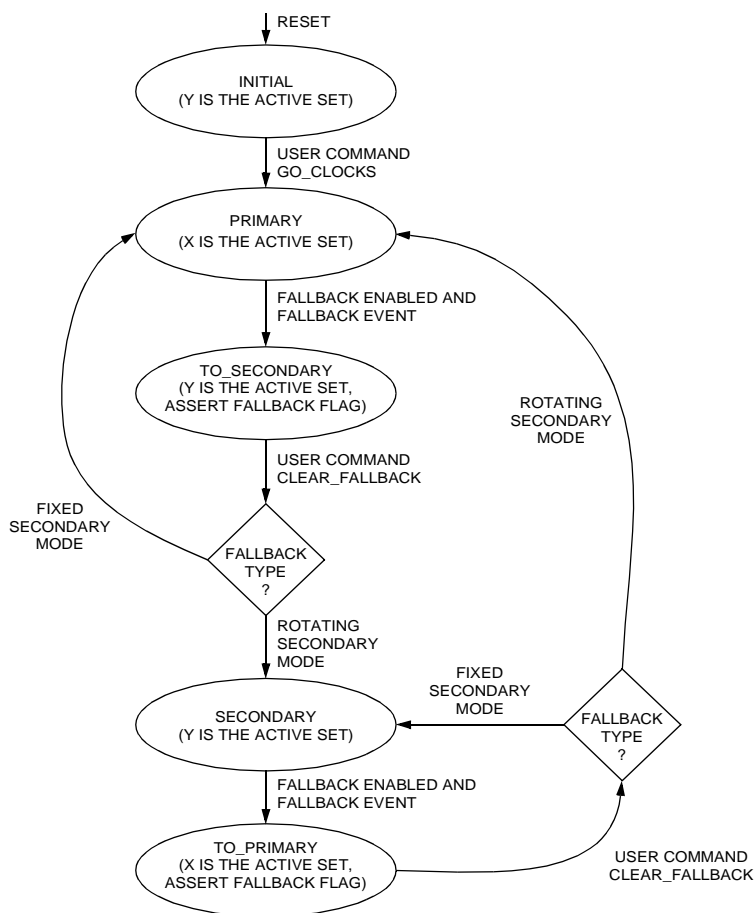

5-9422 (F)

Figure 10. T8110L Clock Fallback States

6 Clock Architecture (continued)

6.7 Clock Circuit Operation—Fallback and Failsafe (continued)

6.7.1 Clock Fallback (continued)

6.7.1.1 Fallback Scenarios—Fixed vs. Rotating Secondary (continued)

Table 54. Clock Fallback State Description

Clock Fallback State	Description	Exit To	Exit Condition
INITIAL	Y is the active clock register set. Default value provides XTAL1-div-4 reference.	PRIMARY	User issues GO_CLOCKS command (set register 0x00108 bit 0).
PRIMARY	X is the active clock register set and controls APLL1 REFCLK.	TO_SECONDARY	Fallback is enabled and fallback event* occurs.
TO_SECONDARY	Y is the active clock register set and controls APLL1 REFCLK. Fallback flag is asserted.	PRIMARY	User issues CLEAR_FALLBACK command (set register 0x00108 bit 1) and fallback type = fixed secondary [†] .
		SECONDARY	User issues CLEAR_FALLBACK command (set register 0x00108 bit 1) and fallback type = rotating secondary [†] .
SECONDARY	Y is the active clock register set and controls APLL1 REFCLK.	TO_PRIMARY	Fallback is enabled and fallback event* occurs.
TO_PRIMARY	X is the active clock register set and controls APLL1 REFCLK. Fallback flag is asserted.	SECONDARY	User issues CLEAR_FALLBACK command (set register 0x00108 bit 1) and fallback type = fixed secondary [†] .
		PRIMARY	User issues CLEAR_FALLBACK command (set register 0x00108 bit 1) and fallback type = rotating secondary [†] .

* Fallback event; refer to Section 6.7.1.1 on page 64.

† Fixed, rotating secondary; refer to Section 6.7.1.2 on page 65.

6 Clock Architecture (continued)

6.7 Clock Circuit Operation—Fallback and Failsafe (continued)

6.7.1 Clock Fallback (continued)

6.7.1.3 H-Bus Clock Enable/Disable on Fallback

The previous *Ambassador* devices allowed a fallback mode (A/B fallback) which automatically allowed an H1x0 bus clock master to detect an error in its own output clock and remove itself from the bus, or a clock slave to detect an error on its incoming clock and **promote** itself to clock master. The H-bus clocks include:

- A clocks: CT_C8_A, /CT_FRAME_A
- B clocks: CT_C8_B, /CT_FRAME_B
- C clocks: /C16±, /C4, C2, SCLK, /SCLKx2, /FR_COMP

Refer to Figure 11 and Table 55. The T8110L allows for this mode of operation in two ways:

Register 0x00109(7:4) = 0100: legacy mode, A/B fallback—when this mode is selected, the fallback triggers allowed are predefined based on the main input clock selection, and the state machine which controls H-bus clock enable/disable is activated.

Register 0x00109(7:4) = 1001: nonlegacy mode—when this mode is selected, the fallback trigger enable registers determine what triggers a fallback, and the state machine which controls H-bus clock enable/disable is activated.

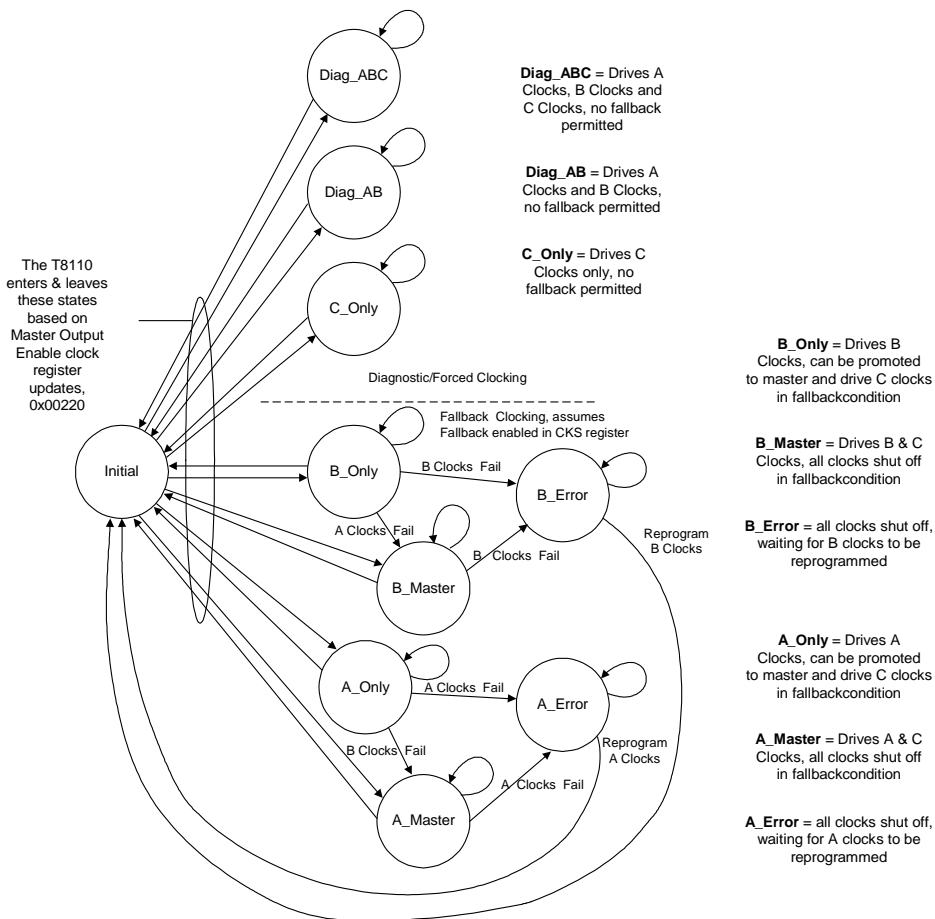

Figure 11. T8110L H-Bus Clock Enable States

6 Clock Architecture (continued)

6.7 Clock Circuit Operation—Fallback and Failsafe (continued)

6.7.1 Clock Fallback (continued)

6.7.1.1 H-Bus Clock Enable/Disable on Fallback (continued)

Table 55. H-Bus Clock Enable State Description

H-Bus Clock Enable State	Description	Exit To	Exit Condition
INITIAL	Initial condition, waiting for clock output control register programming.	Any of the other states	User update of the clock output control register (0x00220, master output enables).
DIAG_ABC	T8110L is driving all H-bus clocks (diagnostic mode).	INITIAL	User update of the clock output control register (0x00220, master output enables).
DIAG_AB	T8110L is driving both the H-bus A and B clocks (diagnostic mode).	INITIAL	User update of the clock output control register (0x00220, master output enables).
C_ONLY	T8110L is driving only the H-bus C clocks.	INITIAL	User update of the clock output control register (0x00220, master output enables).
A_MASTER	T8110L clock output control registers are programmed to drive A clocks and C clocks (T8110L is an A clock master), or T8110L was supplying a backup A clock and has been promoted to A clock master.	A_ERROR	A clock error on CT_C8_A or /CT_FRAME_A is detected; disable clock outputs.
		INITIAL	User update of the clock output control register (0x00220, master output enables).
A_ONLY	T8110L clock output control registers are programmed to drive A clocks only (T8110L is a B clock slave, and supplies a backup A clock).	A_MASTER	A clock error on CT_C8_B or /CT_FRAME_B is detected; promote to A clock master.
		A_ERROR	A clock error on CT_C8_A or /CT_FRAME_A is detected; disable clock outputs.
		INITIAL	User update of the clock output control register (0x00220, master output enables).
A_ERROR	T8110L has detected a clock error while driving the A clocks, and has stopped driving any H bus clocks.	INITIAL	User update of the clock output control register (0x00220, master output enables).
B_MASTER	T8110L clock output control registers are programmed to drive B clocks and C clocks (T8110L is a B clock master), or T8110L was supplying a backup B clock and has been promoted to B clock master.	B_ERROR	A clock error on CT_C8_B or /CT_FRAME_B is detected; disable clock outputs.
		INITIAL	User update of the clock output control register (0x00220, master output enables).
B_ONLY	T8110L clock output control registers are programmed to drive B clocks only (T8110L is an A clock slave, and supplies a backup B clock).	B_MASTER	A clock error on CT_C8_A or /CT_FRAME_A is detected; promote to B clock master.
		B_ERROR	A clock error on CT_C8_B or /CT_FRAME_B is detected; disable clock outputs.
		INITIAL	User update of the clock output control register (0x00220, master output enables).
B_ERROR	T8110L has detected a clock error while driving the B clocks, and has stopped driving any H bus clocks.	INITIAL	User update of the clock output control register (0x00220, master output enables).

6 Clock Architecture (continued)

6.7 Clock Circuit Operation—Fallback and Failsafe (continued)

6.7.2 Clock Failsafe

Clock failsafe provides a safety net for the APLL1 reference clock source and is controlled by three registers, 0x00114—0x00116; see Section 5.1.11 on page 38. A failsafe event overrides the active clock control registers and forces the APLL1 clock selection to be a fixed 4.096 MHz, derived from the XTAL1 crystal, divided by four. Transition into one of the failsafe states is independent of clock fallback (i.e., can enter from any state other than INITIAL). Transitions out of the failsafe states are by user command and allow re-entry into either a nonfallback (primary or secondary) or a fallback (TO_SECONDARY or TO_PRIMARY) state. Refer to Table 56 and Figure 12.

6.7.2.1 Failsafe Events

Clock failsafe (transition from either clock register set to a forced XTAL1-div-4 APLL1 reference clock) can only occur if the failsafe mode is enabled (register 0x00115, lower nibble), and a failsafe event occurs. A failsafe event is triggered by a watchdog error on the APLL1 reference clock (i.e., loss-of-reference).

Additionally, an out-of-lock (OOL) condition is provided for debug purposes. This does not trigger a failsafe event, but does indicate potential difficulty with the APLL1. A lock status flag is provided out of APLL1, and the OOL is defined by exceeding a user-defined threshold value (register 0x00116). The lock status is a flag indicating when APLL1 is making a correction to maintain synchronization. The flag is continuously sampled. If enough active flags are sampled in a row to exceed the user-defined threshold, this condition is reported via the system status register (0x00125).

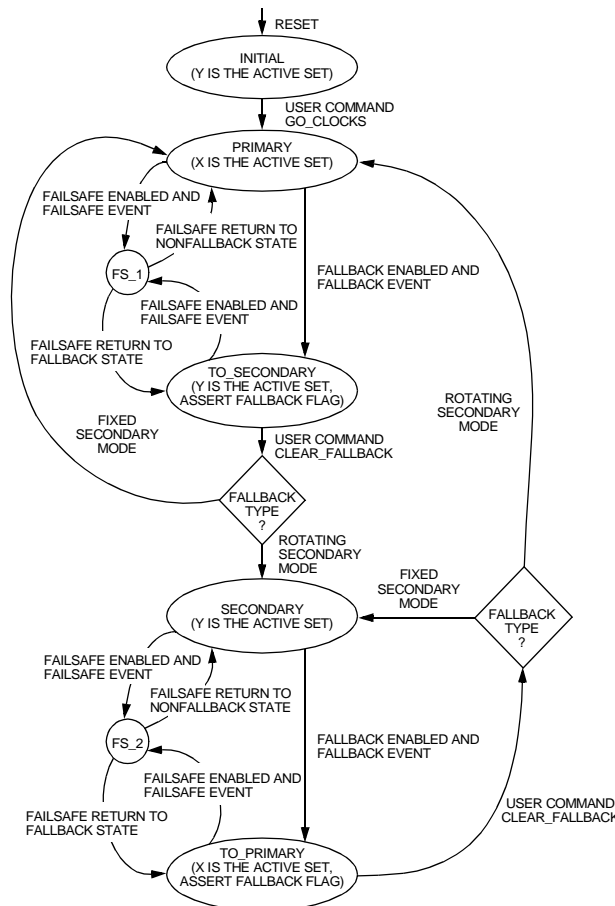

5-9421 (F)

Figure 12. T8110L Clock Failsafe States

6 Clock Architecture (continued)

6.7 Clock Circuit Operation—Fallback and Failsafe (continued)

6.7.2 Clock Failsafe (continued)

6.7.2.1 Failsafe Events (continued)

Table 56. Clock Failsafe State Descriptions

Clock Failsafe State	Description	Exit To	Exit Condition
FS_1	APLL1 REFCLK is forced to XTAL1-div-4. FAILSAFE FLAG is asserted.	PRIMARY	User issues FAILSAFE_RETURN to nonfallback state command (set register 0x00114 bit 0).
		TO_SECONDARY	User issues FAILSAFE_RETURN to fallback state command (set register 0x00114 bit 1).
FS_2	APLL1 REFCLK is forced to XTAL1-div-4. FAILSAFE FLAG is asserted.	SECONDARY	User issues FAILSAFE_RETURN to non-fallback state command (set register 0x00114 bit 0).
		TO_PRIMARY	User issues FAILSAFE_RETURN to fallback state command (set register 0x00114 bit 1).

7 Frame Group and FG I/O

There are eight independently programmable T8110L frame group/FGIO signals, FG[7:0]. In the frame group mode, the pin is an 8 kHz frame reference output, with programmable pulse width, polarity, and delay offset from the internally generated frame reference. In the FGIO mode, the pin behaves as a general-purpose register bit, with programmable direction (IN or OUT) and read masking. The FG7 signal allows for an additional mode of operation, providing a timer via a 16-bit programmable counter.

Table 57. Frame Group and FG I/O Register Map

DWORD Address (20 bits)	Register			
	Byte 3	Byte 2	Byte 1	Byte 0
0x00400	FG0 rate	FG0 width	FG0 upper start	FG0 lower start
0x00410	FG1 rate	FG1 width	FG1 upper start	FG1 lower start
0x00420	FG2 rate	FG2 width	FG2 upper start	FG2 lower start
0x00430	FG3 rate	FG3 width	FG3 upper start	FG3 lower start
0x00440	FG4 rate	FG4 width	FG4 upper start	FG4 lower start
0x00450	FG5 rate	FG5 width	FG5 upper start	FG5 lower start
0x00460	FG6 rate	FG6 width	FG6 upper start	FG6 lower start
0x00470	FG7 rate	FG7 width	FG7 upper start	FG7 lower start
0x00474	FG7 mode upper	FG7 mode lower	FG7 counter high byte	FG7 counter low byte
0x00480	Reserved	FGIO R/W	FGIO read mask	FGIO data register

7.1 Frame Group Control Registers

7.1.1 FGx Lower and Upper Start Registers

The FGx lower and upper start registers provide a 12-bit delay offset value for the corresponding frame group bit. Offsets are relative to the T8110L internally generated 8 kHz frame reference and have a resolution down to one 32.768 MHz clock period (30.5 ns increments).

Table 58. FGx Lower and Upper Start Registers

Byte Address	Name	Bit(s)	Mnemonic	Value	Function
0x00400 0x00410 0x00420 0x00430 0x00440 0x00450 0x00460 0x00470	FG0 Lower Start (FG1 Lower Start) (FG2 Lower Start) (FG3 Lower Start) (FG4 Lower Start) (FG5 Lower Start) (FG6 Lower Start) (FG7 Lower Start)	7:0	F0LLR (F1LLR) (F2LLR) (F3LLR) (F4LLR) (F5LLR) (F6LLR) (F7LLR)	LLLL LLLL	Lower 8 bits of 12-bit start offset.
0x00401 (0x00411) (0x00421) (0x00431) (0x00441) (0x00451) (0x00461) (0x00471)	FG0 Upper Start (FG1 Upper Start) (FG2 Upper Start) (FG3 Upper Start) (FG4 Upper Start) (FG5 Upper Start) (FG6 Upper Start) (FG7 Upper Start)	7:0	F0ULR (F1ULR) (F2ULR) (F3ULR) (F4ULR) (F5ULR) (F6ULR) (F7ULR)	0000 LLLL	Upper 4 bits of 12-bit start offset.

7 Frame Group and FG I/O (continued)

7.1 Frame Group Control Registers (continued)

7.1.2 FGx Width Registers

The FGx width registers control the polarity and the pulse widths generated for the corresponding frame group bit. The pulse-width programming works in conjunction with the FGx rate registers to provide 1-bit, 2-bit, 4-bit, 1-byte, and 2-byte wide pulses for any of the available frame group rates (see Table 59).

Table 59. FGx Width Registers

Byte Address	Name	Bit(s)	Mnemonic	Value	Function
0x00402 (0x00412) (0x00422) (0x00432) (0x00442) (0x00452) (0x00462) (0x00472)	FG0 Width (FG1 Width) (FG2 Width) (FG3 Width) (FG4 Width) (FG5 Width) (FG6 Width) (FG7 Width)	7	F0ISB (F1ISB) (F2ISB) (F3ISB) (F4ISB) (F5ISB) (F6ISB) (F7ISB)	0 1	Generate active-high pulse (default). Generate active-low pulse.
		6:0	F0WSP (F1WSP) (F2WSP) (F3WSP) (F4WSP) (F5WSP) (F6WSP) (F7WSP)	000 0000 000 0001 000 0010 000 0100 001 0000 010 0000	1-bit wide pulse (default). 1-bit wide pulse. 2-bit wide pulse. 4-bit wide pulse. 1-byte wide pulse. 2-byte wide pulse.

7.1.3 FGx Rate Registers

The FGx rate registers either enable FGIO operation* or work in conjunction with FGx width registers to provide various width frame group pulses at rates of 2.048 MHz, 4.096 MHz, 8.192 MHz, or 16.384 MHz.

Table 60. FGx Rate Registers

Byte Address	Name	Bit(s)	Mnemonic	Value	Function
0x00403 (0x00413) (0x00423) (0x00433) (0x00443) (0x00453) (0x00463) (0x00473)	FG0 Rate (FG1 Rate) (FG2 Rate) (FG3 Rate) (FG4 Rate) (FG5 Rate) (FG6 Rate) (FG7 Rate)	7:0	F0RSR (F1RSR) (F2RSR) (F3RSR) (F4RSR) (F5RSR) (F6RSR) (F7RSR)	0000 0000 0000 0001 0000 0010 0000 0100 0000 1000 0000 1001	Off (default). FGIO enabled* (not used as a frame group). FGx rate = 2.048 MHz. FGx rate = 4.096 MHz. FGx rate = 8.192 MHz. FGx rate = 16.384 MHz.

* FGIO operation is controlled at registers 0x00480—482. Refer to Section 7.3 on page 75.

7 Frame Group and FG I/O (continued)

7.2 FG7 Timer Option

The FG7 signal allows for an added function of a timer output, via a 16-bit programmable counter.

7.2.1 FG7 Counter (Low and High Byte) Registers

The FG7 counter (low and high byte) registers set the timer value. The timer is actually a divider, so the value entered must be [divider value – 1], i.e., 0000000000000011 would yield a div-by-4 operation. The FG7 mode lower register enables the timer option, with two clock source options: T8110L internal frame or an external timer clock via the FG6 signal. The FG7 mode upper register controls the shape of the timer pulse. For more details, see Section 7.4.3 on page 79.

Table 61. FG7 Counter (Low and High Byte) Registers

Byte Address	Name	Bit	Mnemonic	Value	Function
0x00474	FG7 Counter, Low Byte	7:0	FCLLR	LLLL LLLL	Lower 8 bits of 16-bit counter value.
0x00475	FG7 Counter, High Byte	7:0	FCULR	LLLL LLLL	Upper 8 bits of 16-bit counter value.
0x00476	FG7 Mode Lower	7:0	F7MSR	0000 0000 0000 0001 0000 0010	Normal operation* (default). Enable timer, clock = internal frame. Enable timer, clock = external FG6.
0x00477	FG7 Mode Upper	7	FCISB	0	Normal FG7 timer output, high pulses (default).
				1	Inverted FG7 timer output, low pulses.
		6:4	F7SSP	000	FG7 timer output off (default).
				001	FG7 timer output = square wave [†] .
010	FG7 timer output = carry out pulse [‡] .				
3:0	F7WSN	0001	Programmable pulse width = 30.5 ns.		
		0010	Programmable pulse width = 61.0 ns.		
		0100	Programmable pulse width = 91.5 ns.		
			1000	Programmable pulse width = 122 ns.	

* Normal operation allows frame group or FGIO control via registers 0x00470—473. Enabling the counter overrides 0x00470—473 settings.

† Square wave is only available when FG7 counter high/low value is a binary multiple 1, 2, 4, 8, 16, etc. Other values yield a carry out pulse shape.

‡ Carry out pulse is active for one FG7 timer clock period.

§ Programmable pulses are based on T8110L internal 32.768 MHz clock periods.

7 Frame Group and FG I/O (continued)

7.3 FGIO Control Registers

7.3.1 FGIO Data Register

The FGIO data register provides read/write access and write storage to/from any FG signals being used as general-purpose register bits. Writes to FGIO work in conjunction with the corresponding FGIO enabled settings in the FGx rate registers. Reads are maskable, controlled via register 0x00481.

Table 62. FGIO Data Register

Byte Address	Name	Bit(s)	Mnemonic	Value	Function
0x00480	FGIO Data Register	7	F7IOB	L	FGIO bit 7 value.
		6	F6IOB	L	FGIO bit 6 value.
		5	F5IOB	L	FGIO bit 5 value.
		4	F4IOB	L	FGIO bit 4 value.
		3	F3IOB	L	FGIO bit 3 value.
		2	F2IOB	L	FGIO bit 2 value.
		1	F1IOB	L	FGIO bit 1 value.
		0	F0IOB	L	FGIO bit 0 value.

7.3.2 FGIO Read Mask Register

The FGIO read mask register controls the masking of any FG signals being used as general-purpose register bits on a read access to the FGIO register.

Table 63. FGIO Read Mask Register

Byte Address	Name	Bit(s)	Mnemonic	Value	Function
0x00481	FGIO Read Mask	7	F7MEB	0	Unmask FGIO bit 7 (default).
				1	Mask FGIO bit 7, return 0 on a read.
		6	F6MEB	0	Unmask FGIO bit 6 (default).
				1	Mask FGIO bit 6, return 0 on a read.
		5	F5MEB	0	Unmask FGIO bit 5 (default).
				1	Mask FGIO bit 5, return 0 on a read.
		4	F4MEB	0	Unmask FGIO bit 4 (default).
				1	Mask FGIO bit 4, return 0 on a read.
3	F3MEB	0	Unmask FGIO bit 3 (default).		
		1	Mask FGIO bit 3, return 0 on a read.		
2	F2MEB	0	Unmask FGIO bit 2 (default).		
		1	Mask FGIO bit 2, return 0 on a read.		
1	F1MEB	0	Unmask FGIO bit 1 (default).		
		1	Mask FGIO bit 1, return 0 on a read.		
0	F0MEB	0	Unmask FGIO bit 0 (default).		
		1	Mask FGIO bit 0, return 0 on a read.		

7 Frame Group and FG I/O (continued)**7.3 FGIO Control Registers** (continued)**7.3.3 FGIO R/W Register**

The FGIO R/W register provides direction control for any of the FG signals being used as general-purpose register bits.

Table 64. FGIO R/W Register

Byte Address	Name	Bit(s)	Mnemonic	Value	Function
0x00482	FGIO R/W	7	F7DSB	0 1	FGIO bit 7 direction is input (default). FGIO bit 7 direction is output.
		6	F6DSB	0 1	FGIO bit 6 direction is input (default). FGIO bit 6 direction is output.
		5	F5DSB	0 1	FGIO bit 5 direction is input (default). FGIO bit 5 direction is output.
		4	F4DSB	0 1	FGIO bit 4 direction is input (default). FGIO bit 4 direction is output.
		3	F3DSB	0 1	FGIO bit 3 direction is input (default). FGIO bit 3 direction is output.
		2	F2DSB	0 1	FGIO bit 2 direction is input (default). FGIO bit 2 direction is output.
		1	F1DSB	0 1	FGIO bit 1 direction is input (default). FGIO bit 1 direction is output.
		0	F0DSB	0 1	FGIO bit 0 direction is input (default). FGIO bit 0 direction is output.

7 Frame Group and FG I/O (continued)

7.4 FG Circuit Operation

Each of the eight frame group signals FG[7:0] operate independently and have multiple uses. Refer to Figure 13 below.

- As programmable 8 kHz frame reference outputs (frame group)
- As general-purpose register I/O bits (FGIO)
- As a programmable timer (FG7 only)
- As external interrupt input signals
- As diagnostic observation points for internal testpoints

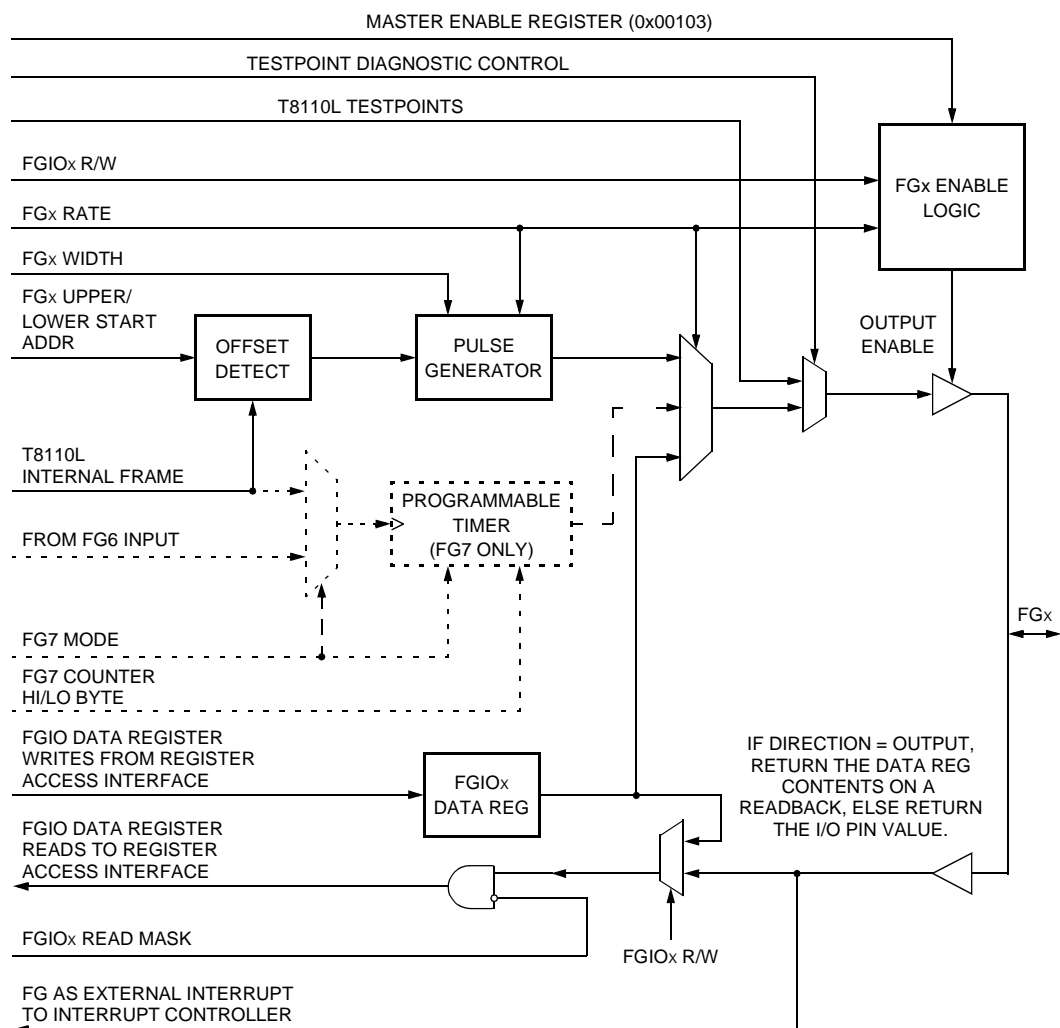

5-9428a (F)

Figure 13. FG[7:0] Functional Paths

7 Frame Group and FG I/O (continued)

7.4 FG Circuit Operation (continued)

7.4.1 Frame Group 8 kHz Reference Generation

Any of the T8110L FG signals may be used as programmable 8 kHz frame reference outputs. There are two sets of control required, an offset delay from internal frame center, and pulse shaping.

The offset delay is provided via the FGx upper/lower start address registers. The delay is relative to the T8110L internal frame center, and the 12 bits used allow for 4096 different offsets, in increments of one 32.768 MHz clock period (30.5 ns).

Pulse shaping is controlled via the FGx width and FGx rate registers. Pulses may be programmed to be active-high or active-low. Pulse width can be either 1-bit, 2-bit, 4-bit, 1-byte or 2-byte wide (relative to the rate setting*), with allowable rate settings of 2.048 MHz, 4.096 MHz, 8.192 MHz, and 16.384 MHz.

*Pulse widths are bit times or multiples of bit times, for each applicable rate:

RATE	BIT TIME
2.048 Mbits/s	488 ns
4.096 Mbits/s	244 ns
8.192 Mbits/s	122 ns
16.384 Mbits/s	61 ns

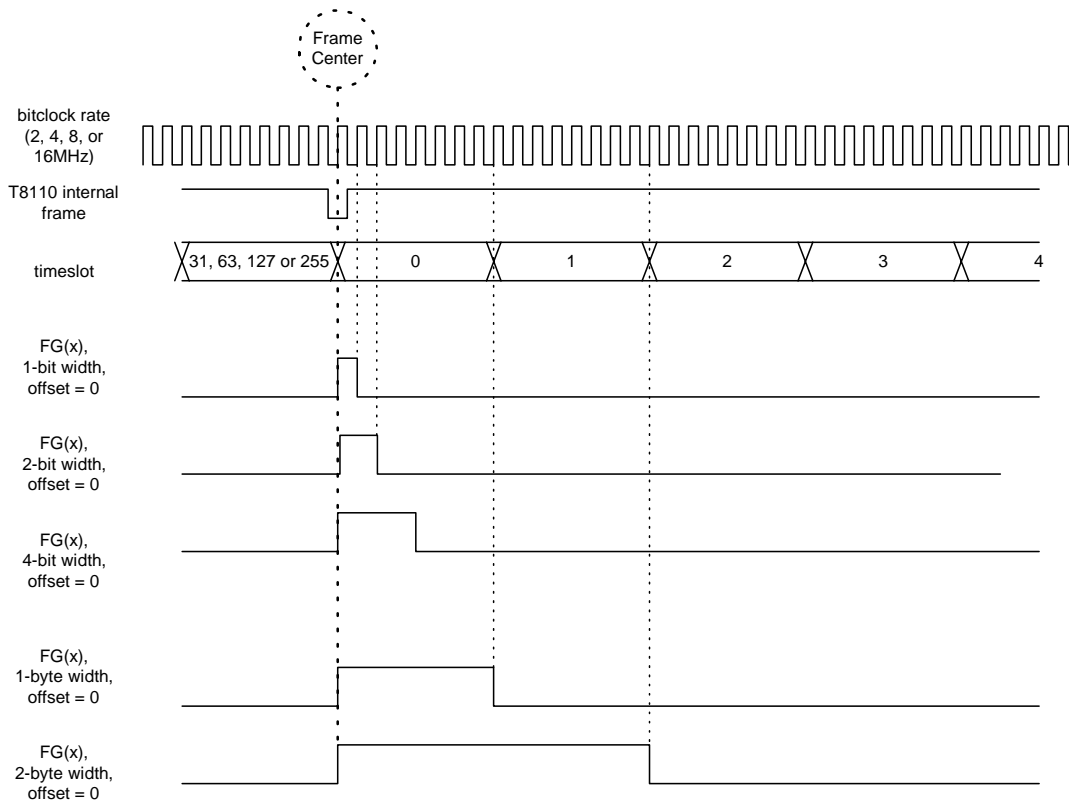

Notes:

Frame group signals shown with offset = 0 (default). At offset = 0, the pulse starts at frame center.

Nonzero offsets denote 32.768 MHz period increments (30.5 ns) from frame center. There are up to 4096 increments within an 8 kHz frame period. Offsets may be programmed in the range from 0—4095.

Frame group signals are shown as active high pulses (default)—they may be programmed as active-low pulses.

Diagram shows frame group pulse widths relative to bit-clock rate and time-slot width. This is applicable for any of the four frame group data rates (2 Mbits/s, 4 Mbits/s, 8 Mbits/s, or 16 Mbits/s).

Figure 14. Frame Group 8 kHz Reference Timing

7 Frame Group and FG I/O (continued)

7.4 FG Circuit Operation (continued)

7.4.2 FGIO General-Purpose Bits

Any of the T8110L FG signals may be used as general-purpose I/O bits. Each FG bit used as FGIO is configured by enabling the FGIO function via the FGx rate register(s) and setting the direction via the appropriate bits in the FGIO R/W register. For write access to the FGIO, the FGIO data register is used to hold data for output to the FG pin(s). Read accesses are maskable via the FGIO read mask register. For read access from the FGIO, the logical state of the FG[7:0] signals is returned if unmasked. If an FGIO bit is masked, a read access returns 0.

7.4.3 Programmable Timer (FG7 Only)

The FG7 signal can be used as a programmable timer output, via the FG7 mode upper/lower, and FG7 counter high and low byte registers. The FG7 timer is simply a clock divider. The FG7 counter high/low provides a 16-bit [divider value – 1].

Note: [divider value – 1], i.e., a value of 0000000000000011 yields a div-by-4 operation.

The FG7 mode lower register enables the counter and selects between two clock sources into the counter: either the T8110L internal frame (8 kHz) or an external clock via the FG6 input. The FG7 mode upper register controls the output pulse shape. The output can be inverted or noninverted and shaped as either a square wave, a carryout pulse, or a programmable-width pulse.

- Square wave. This option is applicable only for divide operations that are binary multiples (i.e., div-by-2, div-by-4, div-by-8, div-by-16, div-by-65536). Nonbinary divide operations while square wave is selected result in a carryout pulse.
- Carryout pulse. The output is a pulse, width = one FG7 timer clock period.
- Programmable-width pulse. The timer output is synchronized to the T8110L 32.768 MHz clock domain and can be programmed for 1, 2, 3, or 4, 32.768 MHz clock periods in width (30.5 ns, 61 ns, 91.5 ns, or 122 ns).

7.4.4 FG External Interrupts

All FG signals are internally connected as inputs to the interrupt controller logic. Any FG signal, whether an output or an input, may be used to trigger interrupts. When a T8110L FG signal is used as an externally sourced input into the interrupt controller logic, it must be in input mode (i.e., shut-off, FGx rate register(s) FxRSR = 0000 0000). An FG signal in output mode may also be used for interrupts (i.e., an 8 kHz periodic signal, see Section 7.4.1 on page 78). The interrupt control registers (0x00600—603) control how the FG inputs are handled (for more details, refer to Section 10.1 on page 90).

7.4.5 FG Diagnostic Test Point Observation

Any of the T8110L FG signals may be used to observe a predefined set of internal testpoints. Each FG bit used as a testpoint output is enabled via diagnostic register 0x00140, FG testpoint enable. Settings in this register override the FGx rate and FGIO R/W register, and force the selected bits to be testpoint outputs, see Section 11.1 on page 106 and Table 88 on page 106.

8 General-Purpose I/O

There are eight independent T8110L GPIO signals, GP[7:0]. These pins behave as general-purpose register bits, with programmable direction (in or out) and read masking. The GP0 and GP1 signals allow for an additional mode of operation, providing dedicated output signals to indicate A clock and B clock mastering for H.110 bus applications.

8.1 GPIO Control Registers

Table 65. GPIO Register

DWORD Address (20 bits)	Register			
	Byte 3	Byte 2	Byte 1	Byte 0
0x00500	GPIO override	GPIO R/W	GPIO read mask	GPIO data register

8.1.1 GPIO Data Register

The GPIO data register provides read/write access and write storage to/from any GP signals being used as general-purpose register bits. Reads from GPIO are maskable, controlled via register 0x00501.

Table 66. GPIO Data Register

Byte Address	Name	Bit(s)	Mnemonic	Value	Function
0x00500	GPIO Data Register	7	G7IOB	L	GPIO bit 7 value.
		6	G6IOB	L	GPIO bit 6 value.
		5	G5IOB	L	GPIO bit 5 value.
		4	G4IOB	L	GPIO bit 4 value.
		3	G3IOB	L	GPIO bit 3 value.
		2	G2IOB	L	GPIO bit 2 value.
		1	G1IOB	L	GPIO bit 1 value.
		0	G0IOB	L	GPIO bit 0 value.

8 General-Purpose I/O (continued)

8.1 GPIO Control Registers (continued)

8.1.2 GPIO Read Mask Register

The GPIO read mask register controls the masking of any GP signals being used as general-purpose register bits on a read access to the GPIO register.

Table 67. GPIO Read Mask Register

Byte Address	Name	Bit(s)	Mnemonic	Value	Function
0x00501	GPIO Read Mask	7	G7MEB	0	Unmask GPIO bit 7 (default).
				1	Mask GPIO bit 7, return 0 on a read.
		6	G6MEB	0	Unmask GPIO bit 6 (default).
				1	Mask GPIO bit 6, return 0 on a read.
		5	G5MEB	0	Unmask GPIO bit 5 (default).
				1	Mask GPIO bit 5, return 0 on a read.
		4	G4MEB	0	Unmask GPIO bit 4 (default).
				1	Mask GPIO bit 4, return 0 on a read.
3	G3MEB	0	Unmask GPIO bit 3 (default).		
		1	Mask GPIO bit 3, return 0 on a read.		
2	G2MEB	0	Unmask GPIO bit 2 (default).		
		1	Mask GPIO bit 2, return 0 on a read.		
1	G1MEB	0	Unmask GPIO bit 1 (default).		
		1	Mask GPIO bit 1, return 0 on a read.		
0	G0MEB	0	Unmask GPIO bit 0 (default).		
		1	Mask GPIO bit 0, return 0 on a read.		

8.1.3 GPIO R/W Register

The GPIO R/W register provides direction control for any of the GP signals being used as general-purpose register bits.

Table 68. GPIO R/W Register

Byte Address	Name	Bit(s)	Mnemonic	Value	Function
0x00502	GPIO R/W	7	G7DSB	0	GPIO bit 7 direction is input (default).
				1	GPIO bit 7 direction is output.
		6	G6DSB	0	GPIO bit 6 direction is input (default).
				1	GPIO bit 6 direction is output.
		5	G5DSB	0	GPIO bit 5 direction is input (default).
				1	GPIO bit 5 direction is output.
		4	G4DSB	0	GPIO bit 4 direction is input (default).
				1	GPIO bit 4 direction is output.
3	G3DSB	0	GPIO bit 3 direction is input (default).		
		1	GPIO bit 3 direction is output.		
2	G2DSB	0	GPIO bit 2 direction is input (default).		
		1	GPIO bit 2 direction is output.		
1	G1DSB	0	GPIO bit 1 direction is input (default).		
		1	GPIO bit 1 direction is output.		
0	G0DSB	0	GPIO bit 0 direction is input (default).		
		1	GPIO bit 0 direction is output.		

8 General-Purpose I/O (continued)

8.1 GPIO Control Registers (continued)

8.1.4 GPIO Override Register

Table 69. GPIO Override Register

Byte Address	Name	Bit(s)	Mnemonic	Value	Function
0x00503	GPIO Override	7:2	Reserved	0000 0	NOP (default).
		1	G1OEB	0 1	GPIO bit 1 is GPIO (default). GPIO bit 1 B-master indicator output.
		0	G0OEB	0 1	GPIO bit 0 is GPIO (default). GPIO bit 0 A-master indicator output.

8.2 GP Circuit Operation

The eight general-purpose I/O group signals GP[7:0] each operate independently and have multiple uses. Please refer to Figure 15 on page 82.

- As general-purpose register I/O bits (GPIO)
- As H.110 bus clock master indicators (GP0, GP1 only)
- As external interrupt input signals
- As diagnostic observation points for internal testpoints

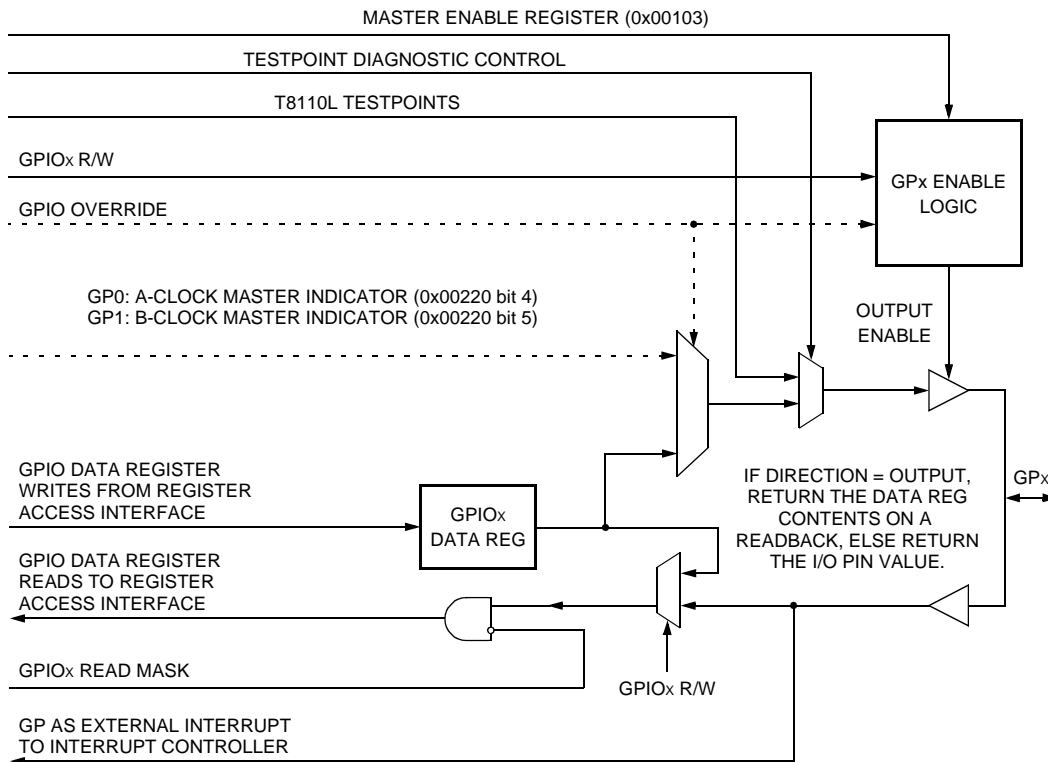

5-9427a (F)

Figure 15. GP[7:0] Functional Paths

8 General-Purpose I/O (continued)

8.2 GP Circuit Operation (continued)

8.2.1 GPIO General-Purpose Bits

Any of the T8110L GP signals may be used as general-purpose I/O bits. Each GP bit used as GPIO is configured by setting the direction via the appropriate bits in the GPIO R/W register. For write access to the GPIO, the GPIO data register is used to hold data for output to the GP pin(s). Read accesses are maskable via the GPIO read mask register. For read access from the GPIO, the logical state of the GP[7:0] signals is returned if unmasked. If a GPIO bit is masked, a read access returns 0.

8.2.2 GP Dual-Purpose Bits GPIO (Override)

8.2.2.1 GP H.110 Clock Master Indicators (GP0, GP1 Only)

An additional function is provided for GP0 and GP1 only, controlled via the GPIO override register.

GP0 may be used as a dedicated output (set GPIO override register bit 0), which transmits the state of the T8110L A clock master enable (register 0x00220, bit 4). This output is intended to drive the external A clock FETs required for H.110 bus mastering.

GP1 may be used as a dedicated output (set GPIO override register bit 1), which transmits the state of the T8110L B clock master enable (register 0x00220, bit 5). This output is intended to drive the external B clock FETs required for H.110 bus mastering.

8.2.3 GP External Interrupts

Any of the T8110L GP signals may be used as externally sourced inputs into the interrupt controller logic. Each GP bit used as an interrupt input must be shut off by setting the appropriate GPIO R/W register bit to be input. The interrupt control registers (0x00604—607) control how the GP inputs are handled. For more details, see Section 10.1 on page 90.

8.2.4 GP Diagnostic Test Point Observation

Any of the T8110L GP signals may be used to observe a predefined set of internal testpoints. Each GP bit used as a testpoint output is enabled via diagnostic register 0x00142, GP testpoint enable. Settings in this register override the GPIO R/W register and force the selected bits to be testpoint outputs (refer to Section 11.1 on page 106, and Table 90 on page 108).

9 Stream Rate Control

There are a total of 64 data streams, divided into 16 stream groups of four streams each, as shown below.

Table 70. T8110L Serial Stream Groupings

Stream Group	Stream Bits
H-bus group A	CT_D[0:3]
H-bus group B	CT_D[4:7]
H-bus group C	CT_D[8:11]
H-bus group D	CT_D[12:15]
H-bus group E	CT_D[16:19]
H-bus group F	CT_D[20:23]
H-bus group G	CT_D[24:27]
H-bus group H	CT_D[28:31]
L-bus group A	LD[0:3]
L-bus group B	LD[4:7]
L-bus group C	LD[8:11]
L-bus group D	LD[12:15]
L-bus group E	LD[16:19]
L-bus group F	LD[20:23]
L-bus group G	LD[24:27]
L-bus group H	LD[28:31]

The H-bus group operational frequencies are selectable between 2.048 MHz, 4.096 MHz, and 8.192 MHz.

The L-bus groups may operate at 2.048 MHz, 4.096 MHz, 8.192 MHz, and 16.384 MHz, which is implemented as multiplexed 8.192 MHz streams. (For more details, see Section 9.2.2 on page 86).

9 Stream Rate Control (continued)

9.1 H-Bus Stream Rate Control Registers

9.1.1 H-Bus Rate Registers

The H-bus rate registers control the serial data stream rate of operation for each of the H-bus stream groups, A—H. The upper nibble controls groups B, D, F, and H. The lower nibble controls groups A, C, E, and G.

Table 71. H-Bus Rate Registers

DWORD Address (20 Bits)	Register			
	Byte 3	Byte 2	Byte 1	Byte 0
0x00300	H-bus rate H/G	H-bus rate F/E	H-bus rate D/C	H-bus rate B/A

Byte Address	Name	Bit(s)	Mnemonic	Value	Function
0x00300	H-bus Rate B/A	7:4	HBRNSN	0000	H-bus group B(D, F, H) off (default).
(0x00301)	(H-bus Rate D/C)		(HDRSN)	0010	H-bus group B(D, F, H) rate = 2.048 MHz.
(0x00302)	(H-bus Rate F/E)		(HFRSN)	0100	H-bus group B(D, F, H) rate = 4.096 MHz.
(0x00303)	(H-bus Rate H/G)		(HHRSN)	1000	H-bus group B(D, F, H) rate = 8.192 MHz.
		3:0	HARSN	0000	H-bus group A(C, E, G) off (default).
			(HCRSN)	0010	H-bus group A(C, E, G) rate = 2.048 MHz.
			(HERSN)	0100	H-bus group A(C, E, G) rate = 4.096 MHz.
			(HGRSN)	1000	H-bus group A(C, E, G) rate = 8.192 MHz.

9.2 L-Bus Stream Rate Control Registers

9.2.1 L-Bus Rate Registers

The L-bus rate registers control the serial data stream rate of operation for each of the L-bus stream groups, A—H. The upper nibble controls groups B, D, F, and H. The lower nibble controls groups A, C, E, and G. Local streams have a 16.384 MHz rate option (refer to Section 9.2.2 on page 86).

Table 72. L-Bus Rate Registers

DWORD Address (20 Bits)	Register			
	Byte 3	Byte 2	Byte 1	Byte 0
0x00320	L-bus rate H/G	L-bus rate F/E	L-bus rate D/C	L-bus rate B/A

Byte Address	Name	Bit(s)	Mnemonic	Value	Function
0x00320	L-bus Rate B/A	7:4	LBRNSN	0000	L-bus group B(D, F, H) off (default).
(0x00321)	(L-bus Rate D/C)		(LDRSN)	0010	L-bus group B(D, F, H) rate = 2.048 MHz.
(0x00322)	(L-bus Rate F/E)		(LFRSN)	0100	L-bus group B(D, F, H) rate = 4.096 MHz.
(0x00323)	(L-bus Rate H/G)		(LHRSN)	1000	L-bus group B(D, F, H) rate = 8.192 MHz.
		3:0	LARSN	0000	L-bus group A(C, E, G) off (default).
			(LCRSN)	0010	L-bus group A(C, E, G) rate = 2.048 MHz.
			(LERSN)	0100	L-bus group A(C, E, G) rate = 4.096 MHz.
			(LGRSN)	1000	L-bus group A(C, E, G) rate = 8.192 MHz.
				1001	L-bus group A(C, E, G) rate = 16.384 MHz.

9 Stream Rate Control (continued)

9.2 L-Bus Stream Rate Control Registers (continued)

9.2.2 L-Bus 16.384 Mbits/s Operation

Local stream 16.384 Mbits/s operation is implemented as two multiplexed 8.192 Mbits/s streams. Bits are shifted at 16.384 MHz, and 16 bits are shifted per 8.192 Mbits/s time slot (refer to Figure 16). This operation makes use of adjacent pairs of the existing single-byte hold and shift registers for local stream operation, with the local even stream assigned as the incoming stream, and the local odd stream assigned as the outgoing stream. Pairs are assigned as LD[0,1], LD[2,3], . . . LD[30,31]. When an L-bus group is set to operate at rate of 16.384 Mbits/s, the hold and shift circuitry is configured such that the serial output of the even stream shift register feeds the serial input of the odd stream shift register (refer to Figure 17).

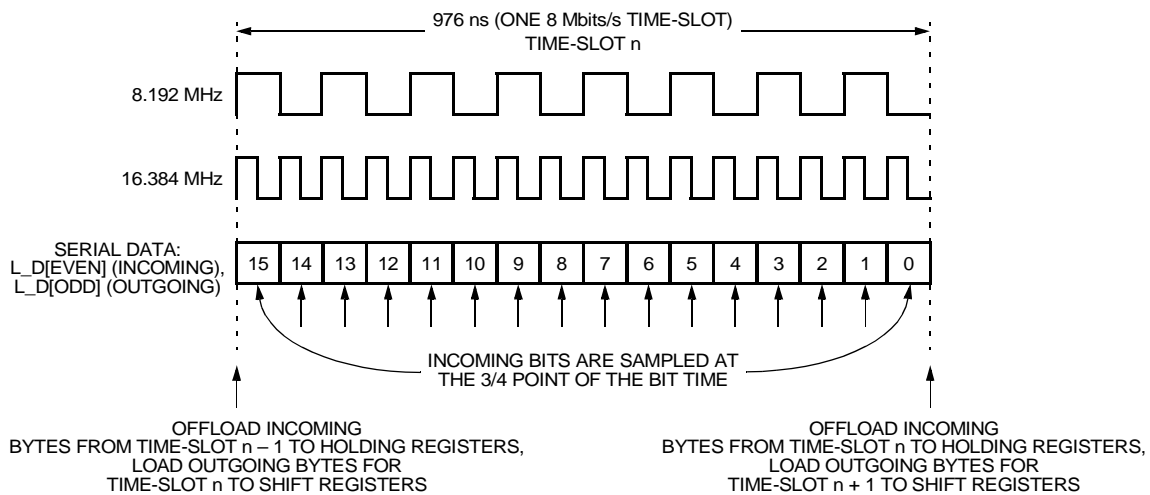

5-9411 (F)

Figure 16. Local Stream 16.384 Mbits/s Timing

9 Stream Rate Control (continued)

9.2 L-Bus Stream Rate Control Registers (continued)

9.2.2 L-Bus 16.384 Mbits/s Operation (continued)

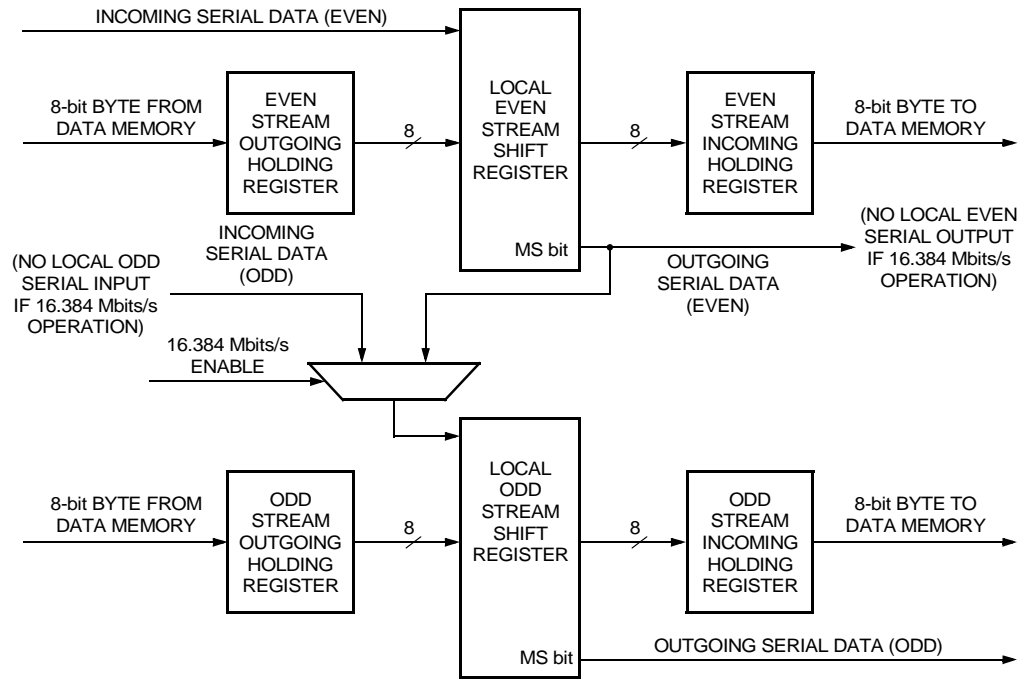

5-9426 (F)

Figure 17. Local Stream 16.384 Mbits/s Circuit

9 Stream Rate Control (continued)

9.2 L-Bus Stream Rate Control Registers (continued)

9.2.3 16.384 Mbits/s Local I/O Superrate

This 16.384 Mbits/s rate option is available only on the local I/O streams (i.e., it is not supported as a part of the H.100/H.110 specifications). When applying the superrate option to a local I/O group, the I/O for the group is redefined and divided into two pairs of input and output. An input or an output can be selected from each pair, but both can't be used simultaneously. This leads to four possible configurations for each group. Note that inputs are always on even signals and outputs are always on odd signals. Thus, if all local groups are operated at the superrate, then the application can have 16 lines, all at 16.384 Mbits/s, in contrast to the 32 I/O lines at normal rates.

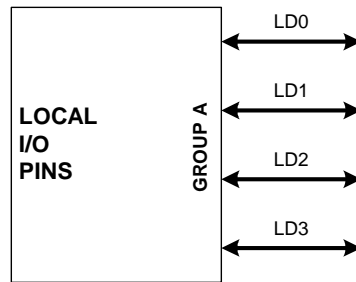

GROUP A CONFIGURATION AT 2.048, 4.096,
OR 8.192 Mbits/s

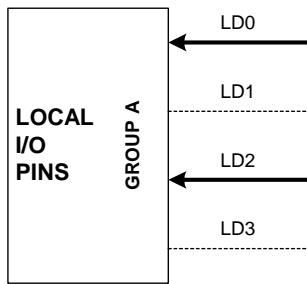

GROUP A CONFIGURATION 1
AT 16.384 Mbits/s SUPERRATE

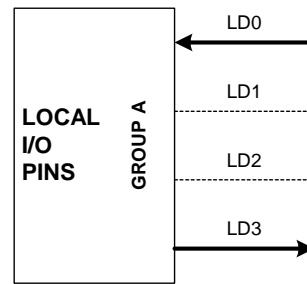

GROUP A CONFIGURATION 2
AT 16.384 Mbits/s SUPERRATE

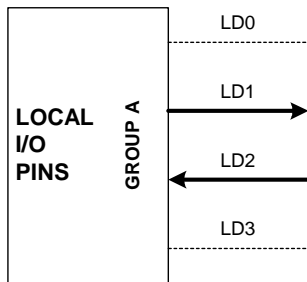

GROUP A CONFIGURATION 3
AT 16.384 Mbits/s SUPERRATE

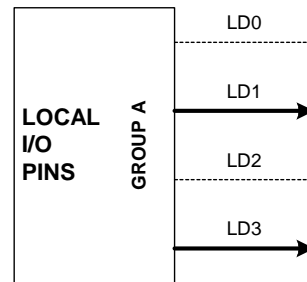

GROUP A CONFIGURATION 4
AT 16.384 Mbits/s SUPERRATE

Figure 18. Superrate I/O Configuration

9 Stream Rate Control (continued)

9.2 L-Bus Stream Rate Control Registers (continued)

9.2.4 16.384 Mbits/s Local I/O Superrate

The configurations are selected as a consequence of the connection programming. The data is inputted or outputted as a true 16-bit at 16.384 Mbits/s signal. Programming a 16-bit connection requires two separate byte connections, one for the MS-byte and the other for the LS-byte.

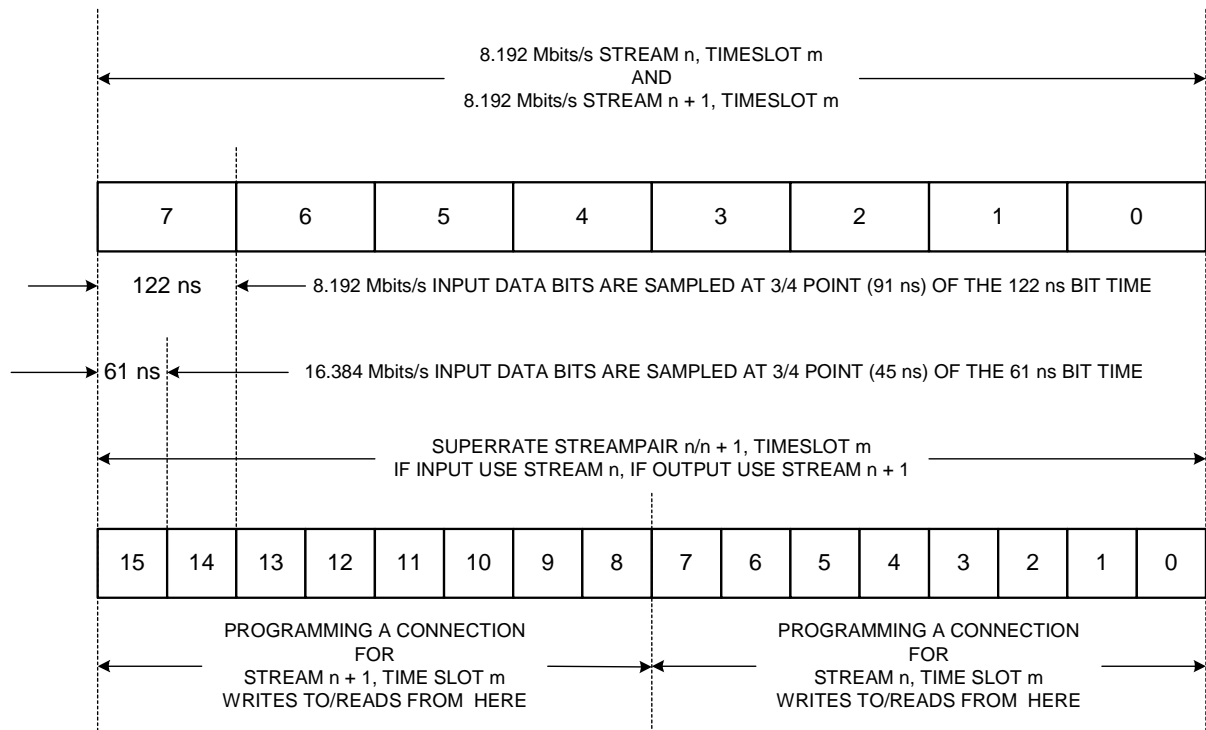

Note: n = even number, m = integer.

Figure 19. Relationship Between 8.192 Mbits/s and 16.384 Mbits/s Time Slots

Thus, programming a connection **to** stream n + 1 is programming a connection to the MS-byte on output pin n + 1 and programming a connection **to** stream n is programming a connection to the LS-byte on output pin n + 1. Similarly, programming a connection **from** stream n + 1 is programming a connection from the MS-byte on input pin n and programming a connection **from** stream n is programming a connection from the LS-byte on input pin n. (An easier way to remember this is that the even/odd identifier becomes the MS-byte/LS-byte identifier.)

As a consequence of this arrangement, the T8110L permits byte-packing at the superrate in analogous manner to subrate bit-packing.

10 Error Reporting and Interrupt Control

10.1 Interrupt Control Registers

Table 73. Interrupt Control Register Map

DWORD Address (20 bits)	Register			
	Byte 3	Byte 2	Byte 1	Byte 0
0x00600	FGIO polarity	Reserved	FGIO interrupt enable	FGIO interrupt pending
0x00604	GPIO polarity	Reserved	GPIO interrupt enable	GPIO interrupt pending
0x00608	System interrupt enable high	System interrupt enable low	System interrupt pending high	System interrupt pending low
0x0060C	Clock interrupt enable high	Clock interrupt enable low	Clock interrupt pending high	Clock interrupt pending low
0x00610	CLKERR output select	SYSERR output select	Reserved	Arbitration control
0x00614	CLKERR pulse width	SYSERR pulse width	Reserved	Reserved
0x006FC	Reserved	Reserved	In-service, high	In-service, low

10.1.1 Interrupts Via External FG[7:0] Registers

10.1.1.1 FGIO Interrupt Pending Register

The FGIO interrupt pending register stores detected interrupts via the FG[7:0] signals. The user can clear specific pending bits by writing 1 to that bit (write 1 to clear). Interrupts via these signals are maskable via the FGIO interrupt enable register.

Table 74. FGIO Interrupt Pending Registers

Byte Address	Name	Bit(s)	Mnemonic	Value	Function
0x00600	FGIO Interrupt Pending	7	JF7OB	0 1	No pending interrupts via FG7 (default). Pending interrupt via FG7.
		6	JF6OB	0 1	No pending interrupts via FG6 (default). Pending interrupt via FG6.
		5	JF5OB	0 1	No pending interrupts via FG5 (default). Pending interrupt via FG5.
		4	JF4OB	0 1	No pending interrupts via FG4 (default). Pending interrupt via FG4.
		3	JF3OB	0 1	No pending interrupts via FG3 (default). Pending interrupt via FG3.
		2	JF2OB	0 1	No pending interrupts via FG2 (default). Pending interrupt via FG2.
		1	JF1OB	0 1	No pending interrupts via FG1 (default). Pending interrupt via FG1.
		0	JF0OB	0 1	No pending interrupts via FG0 (default). Pending interrupt via FG0.

10 Error Reporting and Interrupt Control (continued)

10.1 Interrupt Control Registers (continued)

10.1.1 Interrupts Via External FG[7:0] Registers (continued)

10.1.1.1 FGIO Interrupt Pending Register (continued)

Table 74. FGIO Interrupt Pending Registers (continued)

Byte Address	Name	Bit(s)	Mnemonic	Value	Function
0x00601	FGIO Interrupt Enable	7	JF7EB	0 1	Disable (mask) interrupts via FG7 (default). Enable (unmask) interrupts via FG7.
		6	JF6EB	0 1	Disable (mask) interrupts via FG6 (default). Enable (unmask) interrupts via FG6.
		5	JF5EB	0 1	Disable (mask) interrupts via FG5 (default). Enable (unmask) interrupts via FG5.
		4	JF4EB	0 1	Disable (mask) interrupts via FG4 (default). Enable (unmask) interrupts via FG4.
		3	JF3EB	0 1	Disable (mask) interrupts via FG3 (default). Enable (unmask) interrupts via FG3.
		2	JF2EB	0 1	Disable (mask) interrupts via FG2 (default). Enable (unmask) interrupts via FG2.
		1	JF1EB	0 1	Disable (mask) interrupts via FG1 (default). Enable (unmask) interrupts via FG1.
		0	JF0EB	0 1	Disable (mask) interrupts via FG0 (default). Enable (unmask) interrupts via FG0.

The FGIO edge/level and FGIO polarity registers control how interrupts are interpreted on the GP[7:0] signals (negative edge, positive edge, low level, or high level).

Table 75. FGIO Edge/Level and Polarity Registers

Byte Address	Name	Bit(s)	Mnemonic	Value	Function
0x00603	FGIO Polarity	7	IF7SB	0 1	FG7 interrupts are negative edge or low level (default). FG7 interrupts are positive edge or high level.
		6	IF6SB	0 1	FG6 interrupts are negative edge or low level (default). FG6 interrupts are positive edge or high level.
		5	IF5SB	0 1	FG5 interrupts are negative edge or low level (default). FG5 interrupts are positive edge or high level.
		4	IF4SB	0 1	FG4 interrupts are negative edge or low level (default). FG4 interrupts are positive edge or high level.
		3	IF3SB	0 1	FG3 interrupts are negative edge or low level (default). FG3 interrupts are positive edge or high level.
		2	IF2SB	0 1	FG2 interrupts are negative edge or low level (default). FG2 interrupts are positive edge or high level.
		1	IF1SB	0 1	FG1 interrupts are negative edge or low level (default). FG1 interrupts are positive edge or high level.
		0	IF0SB	0 1	FG0 interrupts are negative edge or low level (default). FG0 interrupts are positive edge or high level.

10 Error Reporting and Interrupt Control (continued)**10.1 Interrupt Control Registers** (continued)**10.1.2 Interrupts Via External GP[7:0]****10.1.2.1 GPIO Interrupt Pending Register**

The GPIO interrupt pending register stores detected interrupts via the GP[7:0] signals. The user can clear specific pending bits by writing 1 to that bit (write 1 to clear). Interrupts via these signals are maskable via the GPIO interrupt enable register.

Table 76. GPIO Interrupt Pending Register

Byte Address	Name	Bit(s)	Mnemonic	Value	Function
0x00604	GPIO Interrupt Pending	7	JG7OB	0 1	No pending interrupts via GP7 (default). Pending interrupt via GP7.
		6	JG6OB	0 1	No pending interrupts via GP6 (default). Pending interrupt via GP6.
		5	JG5OB	0 1	No pending interrupts via GP5 (default). Pending interrupt via GP5.
		4	JG4OB	0 1	No pending interrupts via GP4 (default). Pending interrupt via GP4.
		3	JG3OB	0 1	No pending interrupts via GP3 (default). Pending interrupt via GP3.
		2	JG2OB	0 1	No pending interrupts via GP2 (default). Pending interrupt via GP2.
		1	JG1OB	0 1	No pending interrupts via GP1 (default). Pending interrupt via GP1.
		0	JG0OB	0 1	No pending interrupts via GP0 (default). Pending interrupt via GP0.
0x00605	GPIO Interrupt Enable	7	JG7EB	0 1	Disable (mask) interrupts via GP7 (default). Enable (unmask) interrupts via GP7.
		6	JG6EB	0 1	Disable (mask) interrupts via GP6 (default). Enable (unmask) interrupts via GP6.
		5	JG5EB	0 1	Disable (mask) interrupts via GP5 (default). Enable (unmask) interrupts via GP5.
		4	JG4EB	0 1	Disable (mask) interrupts via GP4 (default). Enable (unmask) interrupts via GP4.
		3	JG3EB	0 1	Disable (mask) interrupts via GP3 (default). Enable (unmask) interrupts via GP3.
		2	JG2EB	0 1	Disable (mask) interrupts via GP2 (default). Enable (unmask) interrupts via GP2.
		1	JG1EB	0 1	Disable (mask) interrupts via GP1 (default). Enable (unmask) interrupts via GP1.
		0	JG0EB	0 1	Disable (mask) interrupts via GP0 (default). Enable (unmask) interrupts via GP0.

10 Error Reporting and Interrupt Control (continued)

10.1 Interrupt Control Registers (continued)

10.1.2 Interrupts Via External GP[7:0] (continued)

10.1.2.2 GPIO Edge/Level and GPIO Polarity Registers

The GPIO edge/level and GPIO polarity registers control how interrupts are interpreted on the GP[7:0] signals (negative edge, positive edge, low level, or high level).

Table 77. GPIO Edge/Level and GPIO Polarity Registers

Byte Address	Name	Bit(s)	Mnemonic	Value	Function
0x00607	GPIO Polarity	7	IG7SB	0 1	GP7 interrupts are negative edge or low level (default). GP7 interrupts are positive edge or high level.
		6	IG6SB	0 1	GP6 interrupts are negative edge or low level (default). GP6 interrupts are positive edge or high level.
		5	IG5SB	0 1	GP5 interrupts are negative edge or low level (default). GP5 interrupts are positive edge or high level.
		4	IG4SB	0 1	GP4 interrupts are negative edge or low level (default). GP4 interrupts are positive edge or high level.
		3	IG3SB	0 1	GP3 interrupts are negative edge or low level (default). GP3 interrupts are positive edge or high level.
		2	IG2SB	0 1	GP2 interrupts are negative edge or low level (default). GP2 interrupts are positive edge or high level.
		1	IG1SB	0 1	GP1 interrupts are negative edge or low level (default). GP1 interrupts are positive edge or high level.
		0	IF0SB	0 1	GP0 interrupts are negative edge or low level (default). GP0 interrupts are positive edge or high level.

10.1.3 Interrupts Via Internal System Errors

Table 78. System Error Interrupt Assignments

System Interrupt Bit	Description
SYS15	Clock failsafe indicator.
SYS14	Clock fallback indicator.
SYS13	Reserved.
SYS12	Reserved.
SYS11	Reserved.
SYS10	Reserved.
SYS9	Reserved.
SYS8	Reserved.
SYS7	Reserved.
SYS6	Reserved.
SYS5	Reserved.
SYS4	Reserved.
SYS3	Reserved.
SYS2	Reserved.
SYS1	Reserved.
SYS0	Reserved.

10 Error Reporting and Interrupt Control (continued)

10.1 Interrupt Control Registers (continued)

10.1.4 System Interrupt Pending High/Low Registers

The system interrupt pending high/low registers store detected interrupts via the internal system error signals. The user can clear specific bits by writing 1 to that bit (write 1 to clear).

Table 79. System Interrupt Pending High/Low Registers

Byte Address	Name	Bit(s)	Mnemonic	Value	Function
0x00608	System Interrupt Pending Low	7	JS7OB	0 1	No pending interrupts via SYS7 (default). Pending interrupt via SYS7.
		6	JS6OB	0 1	No pending interrupts via SYS6 (default). Pending interrupt via SYS6.
		5	JS5OB	0 1	No pending interrupts via SYS5 (default). Pending interrupt via SYS5.
		4	JS4OB	0 1	No pending interrupts via SYS4 (default). Pending interrupt via SYS4.
		3	JS3OB	0 1	No pending interrupts via SYS3 (default). Pending interrupt via SYS3.
		2	JS2OB	0 1	No pending interrupts via SYS2 (default). Pending interrupt via SYS2.
		1	JS1OB	0 1	No pending interrupts via SYS1 (default). Pending interrupt via SYS1.
		0	JS0OB	0 1	No pending interrupts via SYS0 (default). Pending interrupt via SYS0.
0x00609	System Interrupt Pending High	7	JSFOB	0 1	No pending interrupts via SYS15 (default). Pending interrupt via SYS15.
		6	JSEOB	0 1	No pending interrupts via SYS14 (default). Pending interrupt via SYS14.
		5	JSDOB	0 1	No pending interrupts via SYS13 (default). Pending interrupt via SYS13.
		4	JSCOB	0 1	No pending interrupts via SYS12 (default). Pending interrupt via SYS12.
		3	JSBOB	0 1	No pending interrupts via SYS11 (default). Pending interrupt via SYS11.
		2	JSAOB	0 1	No pending interrupts via SYS10 (default). Pending interrupt via SYS10.
		1	JS9OB	0 1	No pending interrupts via SYS9 (default). Pending interrupt via SYS9.
		0	JS8OB	0 1	No pending interrupts via SYS8 (default). Pending interrupt via SYS8.

10 Error Reporting and Interrupt Control (continued)

10.1 Interrupt Control Registers (continued)

10.1.5 System Interrupt Enable High/Low Registers

The system interrupt enable high/low registers allow for masking of interrupts via the internal system error signals.

Table 80. System Interrupt Enable High/Low Registers

Byte Address	Name	Bit(s)	Mnemonic	Value	Function
0x0060A	System Interrupt Enable Low	7	JS7EB	0 1	Disable (mask) interrupts via SYS7 (default). Enable (unmask) interrupts via SYS7.
		6	JS6EB	0 1	Disable (mask) interrupts via SYS6 (default). Enable (unmask) interrupts via SYS6.
		5	JS5EB	0 1	Disable (mask) interrupts via SYS5 (default). Enable (unmask) interrupts via SYS5.
		4	JS4EB	0 1	Disable (mask) interrupts via SYS4 (default). Enable (unmask) interrupts via SYS4.
		3	JS3EB	0 1	Disable (mask) interrupts via SYS3 (default). Enable (unmask) interrupts via SYS3.
		2	JS2EB	0 1	Disable (mask) interrupts via SYS2 (default). Enable (unmask) interrupts via SYS2.
		1	JS1EB	0 1	Disable (mask) interrupts via SYS1 (default). Enable (unmask) interrupts via SYS1.
		0	JS0EB	0 1	Disable (mask) interrupts via SYS0 (default). Enable (unmask) interrupts via SYS0.
0x0060B	System Interrupt Enable High	7	JSFEB	0 1	Disable (mask) interrupts via SYS15 (default). Enable (unmask) interrupts via SYS15.
		6	JSEEB	0 1	Disable (mask) interrupts via SYS14 (default). Enable (unmask) interrupts via SYS14.
		5	JSDEB	0 1	Disable (mask) interrupts via SYS13 (default). Enable (unmask) interrupts via SYS13.
		4	JSCEB	0 1	Disable (mask) interrupts via SYS12 (default). Enable (unmask) interrupts via SYS12.
		3	JSBEB	0 1	Disable (mask) interrupts via SYS11 (default). Enable (unmask) interrupts via SYS11.
		2	JSAEB	0 1	Disable (mask) interrupts via SYS10 (default). Enable (unmask) interrupts via SYS10.
		1	JS9EB	0 1	Disable (mask) interrupts via SYS9 (default). Enable (unmask) interrupts via SYS9.
		0	JS8EB	0 1	Disable (mask) interrupts via SYS8 (default). Enable (unmask) interrupts via SYS8.

10 Error Reporting and Interrupt Control (continued)

10.1 Interrupt Control Registers (continued)

10.1.6 Interrupts Via Internal Clock Errors

Table 81. Clock Error Interrupt Assignments

Clock Interrupt Bit	Description
CLK15	Failsafe indicator—APLL1 reference error.
CLK14	DPLL2 sync input error.
CLK13	DPLL1 sync input error.
CLK12	CT_NETREF2 error.
CLK11	CT_NETREF1 error.
CLK10	/FR_COMP error.
CLK9	/CT_FRAME_B error.
CLK8	/CT_FRAME_A error.
CLK7	/SCLKx2 error.
CLK6	SCLK error.
CLK5	C2 error.
CLK4	/C4 error.
CLK3	/C16– error.
CLK2	/C16+ error.
CLK1	CT_C8_B error.
CLK0	CT_C8_A error.

10 Error Reporting and Interrupt Control (continued)

10.1 Interrupt Control Registers (continued)

10.1.7 Clock Interrupt Pending High/Low Registers

The clock interrupt pending high/low registers store detected interrupts via the internal clock error signals (refer to Section 5.2.1 on page 40). The user can clear specific bits by writing 1 to that bit (write 1 to clear).

Table 82. Clock Interrupt Pending High/Low Registers

Byte Address	Name	Bit(s)	Mnemonic	Value	Function
0x0060C	Clock Interrupt Pending Low	7	JC7OB	0 1	No pending interrupts via CLK7 (default). Pending interrupt via CLK7.
		6	JC6OB	0 1	No pending interrupts via CLK6 (default). Pending interrupt via CLK6.
		5	JC5OB	0 1	No pending interrupts via CLK5 (default). Pending interrupt via CLK5.
		4	JC4OB	0 1	No pending interrupts via CLK4 (default). Pending interrupt via CLK4.
		3	JC3OB	0 1	No pending interrupts via CLK3 (default). Pending interrupt via CLK3.
		2	JC2OB	0 1	No pending interrupts via CLK2 (default). Pending interrupt via CLK2.
		1	JC1OB	0 1	No pending interrupts via CLK1 (default). Pending interrupt via CLK1.
		0	JC0OB	0 1	No pending interrupts via CLK0 (default). Pending interrupt via CLK0.
0x0060D	Clock Interrupt Pending High	7	JCFOB	0 1	No pending interrupts via CLK15 (default). Pending interrupt via CLK15.
		6	JCEOB	0 1	No pending interrupts via CLK14 (default). Pending interrupt via CLK14.
		5	JCDOB	0 1	No pending interrupts via CLK13 (default). Pending interrupt via CLK13.
		4	JCCOB	0 1	No pending interrupts via CLK12 (default). Pending interrupt via CLK12.
		3	JCBOB	0 1	No pending interrupts via CLK11 (default). Pending interrupt via CLK11.
		2	JCAOB	0 1	No pending interrupts via CLK10 (default). Pending interrupt via CLK10.
		1	JC9OB	0 1	No pending interrupts via CLK9 (default). Pending interrupt via CLK9.
		0	JC8OB	0 1	No pending interrupts via CLK8 (default). Pending interrupt via CLK8.

10 Error Reporting and Interrupt Control (continued)**10.1 Interrupt Control Registers** (continued)**10.1.8 Clock Interrupt Enable High/Low Registers**

The clock interrupt enable high/low registers allow for masking of interrupts via the internal clock error signals.

Table 83. Clock Interrupt Enable High/Low Registers

Byte Address	Name	Bit(s)	Mnemonic	Value	Function
0x0060E	Clock Interrupt Enable Low	7	JC7EB	0 1	Disable (mask) interrupts via CLK7 (default). Enable (unmask) interrupts via CLK7.
		6	JC6EB	0 1	Disable (mask) interrupts via CLK6 (default). Enable (unmask) interrupts via CLK6.
		5	JC5EB	0 1	Disable (mask) interrupts via CLK5 (default). Enable (unmask) interrupts via CLK5.
		4	JC4EB	0 1	Disable (mask) interrupts via CLK4 (default). Enable (unmask) interrupts via CLK4.
		3	JC3EB	0 1	Disable (mask) interrupts via CLK3 (default). Enable (unmask) interrupts via CLK3.
		2	JC2EB	0 1	Disable (mask) interrupts via CLK2 (default). Enable (unmask) interrupts via CLK2.
		1	JC1EB	0 1	Disable (mask) interrupts via CLK1 (default). Enable (unmask) interrupts via CLK1.
		0	JC0EB	0 1	Disable (mask) interrupts via CLK0 (default). Enable (unmask) interrupts via CLK0.
0x0060F	Clock Interrupt Enable High	7	JCFEB	0 1	Disable (mask) interrupts via CLK15 (default). Enable (unmask) interrupts via CLK15.
		6	JCEEB	0 1	Disable (mask) interrupts via CLK14 (default). Enable (unmask) interrupts via CLK14.
		5	JCDEB	0 1	Disable (mask) interrupts via CLK13 (default). Enable (unmask) interrupts via CLK13.
		4	JCCEB	0 1	Disable (mask) interrupts via CLK12 (default). Enable (unmask) interrupts via CLK12.
		3	JCBEB	0 1	Disable (mask) interrupts via CLK11 (default). Enable (unmask) interrupts via CLK11.
		2	JCAEB	0 1	Disable (mask) interrupts via CLK10 (default). Enable (unmask) interrupts via CLK10.
		1	JC9EB	0 1	Disable (mask) interrupts via CLK9 (default). Enable (unmask) interrupts via CLK9.
		0	JC8EB	0 1	Disable (mask) interrupts via CLK8 (default). Enable (unmask) interrupts via CLK8.

10 Error Reporting and Interrupt Control (continued)

10.1 Interrupt Control Registers (continued)

10.1.9 Interrupt Servicing Registers

10.1.9.1 Arbitration Control Register

The arbitration control register allows for four modes of interrupt control operation as shown below:

- Disabled. This mode bypasses any interrupt controller operation. No FG or GP inputs are allowed as external interrupt inputs. SYSERR assertion is a simple logical OR of the internal system error bits. CLKERR assertion is a simple logical OR of the internal clock error bits.
- Flat. This mode treats all 48 possible inputs (eight from external FG[7:0], eight from external GP[7:0], 16 from internal system errors, 16 from internal clock errors) with equal weight, and queues them for in-service via a round-robin arbitration.
- Tier, no pre-empting. This mode assigns three priority levels. The highest level is internal clock errors CLK[15:0]; next level is internal system errors SYS[15:0]; lowest level is external errors FG[7:0] and GP[7:0]. Arbitration priority encodes between the three levels. Multiple interrupts within a level are queued round-robin.
- Tier, with pre-empting. This mode is the same as tier, with the added ability to pre-empt a current in-service interrupt according to the three priority levels.

Table 84. Arbitration Control Register

Byte Address	Name	Bit(s)	Mnemonic	Value	Function
0x00610	Arbitration Control	7:0	JAMSR	0000 0000 0000 0001 0000 0010 0001 0010	Disable interrupt controller (default). Flat structure (round-robin arbiter). Tier structure (three levels), no pre-empting. Tier structure (three levels), pre-empting.

10.1.9.2 SYSERR and CLKERR Output Select Register

The SYSERR output select register controls how the SYSERR signal is asserted (active-high level, active-low level, active-high pulse, or active-low pulse).

The SYSERR pulse-width register controls how wide the SYSERR pulse is (when selected output format = high or low pulse). Value corresponds to the number of 32.768 MHz periods – 1.

The CLKERR output select register controls how the CLKERR signal is asserted (active-high level, active-low level, active-high pulse, or active-low pulse).

The CLKERR pulse-width register controls how wide the CLKERR pulse is (when selected output format = high or low pulse). Value corresponds to the number of 32.768 MHz periods – 1.

10 Error Reporting and Interrupt Control (continued)**10.1 Interrupt Control Registers** (continued)**10.1.9 Interrupt Servicing Registers** (continued)**10.1.9.2 SYSERR and CLKERR Output Select Register** (continued)**Table 85. SYSERR Output Select Registers**

Byte Address	Name	Bit(s)	Mnemonic	Value	Function
0x00612	SYSERR Output Select	7:0	JSOSR	0000 0000 0000 0001 0001 0000 0001 0001	SYSERR is active-high level* (default). SYSERR is active-low level*. SYSERR is active-high single pulse. SYSERR is active-low single pulse.
0x00616	SYSERR Pulse Width	7:0	JSWSR	LLLL LLLL	SYSERR pulse-width value.
0x00613	CLKERR Output Select	7:0	JCOSR	0000 0000 0000 0001 0001 0000 0001 0001	CLKERR is active-high level* (default). CLKERR is active-low level*. CLKERR is active-high single pulse. CLKERR is active-low single pulse.
0x00617	CLKERR Pulse Width	7:0	JCWSR	LLLL LLLL	CLKERR pulse-width value.

* When the arbitration control is disabled (0x00610 = 0000 0000), SYSERR or CLKERR levels remain asserted until all the internal system (or clock) pending bits are cleared.

10 Error Reporting and Interrupt Control (continued)

10.1 Interrupt Control Registers (continued)

10.1.9 Interrupt Servicing Registers (continued)

10.1.9.3 Interrupt In-Service Registers

The interrupt in-service registers provide a 16-bit interrupt vector, with unique encoding to indicate which of the 48 possible interrupts is currently in-service.

Table 86. Interrupt In-Service Register

Byte Address	Register Name	Bit(s)	Mnemonic	Value	Function
0x006FC	Interrupt In-service Low	7:0	Reserved	0000 000	Lower byte of in-service vector; returns zero.
0x006FD	Interrupt In-service High	7:0	JISOR	0000 0000 0001 0000 0001 0001 0001 0010 0001 0011 0001 0100 0001 0101 0001 0110 0001 0111 0010 0000 0010 0001 0010 0010 0010 0011 0010 0100 0010 0101 0010 0110 0010 0111 0100 0000 0100 0001 0100 0010 0100 0011 0100 0100 0100 0101	No interrupt in-service (default). FG0 interrupt in-service. FG1 interrupt in-service. FG2 interrupt in-service. FG3 interrupt in-service. FG4 interrupt in-service. FG5 interrupt in-service. FG6 interrupt in-service. FG7 interrupt in-service. GP0 interrupt in-service. GP1 interrupt in-service. GP2 interrupt in-service. GP3 interrupt in-service. GP4 interrupt in-service. GP5 interrupt in-service. GP6 interrupt in-service. GP7 interrupt in-service. SYS0 interrupt in-service. SYS1 interrupt in-service. SYS2 interrupt in-service. SYS3 interrupt in-service. SYS4 interrupt in-service. SYS5 interrupt in-service.

10 Error Reporting and Interrupt Control (continued)

10.1 Interrupt Control Registers (continued)

10.1.9 Interrupt Servicing Registers (continued)

10.1.9.3 Interrupt In-Service Registers (continued)

The interrupt in-service registers provide a 16-bit interrupt vector, with unique encoding to indicate which of the 48 possible interrupts is currently in-service.

Table 86. Interrupt In-Service Register (continued)

Byte Address	Register Name	Bit(s)	Mnemonic	Value	Function
0x006FD	Interrupt In-service High	7:0		0100 0110	SYS6 interrupt in-service.
				0100 0111	SYS7 interrupt in-service.
				0100 1000	SYS8 interrupt in-service.
				0100 1001	SYS9 interrupt in-service.
				0100 1010	SYS10 interrupt in-service.
				0100 1011	SYS11 interrupt in-service.
				0100 1100	SYS12 interrupt in-service.
				0100 1101	SYS13 interrupt in-service.
				0100 1110	SYS14 interrupt in-service.
				0100 1111	SYS15 interrupt in-service.
				1000 0000	CLK0 interrupt in-service.
				1000 0001	CLK1 interrupt in-service.
				1000 0010	CLK2 interrupt in-service.
				1000 0011	CLK3 interrupt in-service.
				1000 0100	CLK4 interrupt in-service.
				1000 0101	CLK5 interrupt in-service.
				1000 0110	CLK6 interrupt in-service.
				1000 0111	CLK7 interrupt in-service.
				1000 1000	CLK8 interrupt in-service.
				1000 1001	CLK9 interrupt in-service.
1000 1010	CLK10 interrupt in-service.				
1000 1011	CLK11 interrupt in-service.				
1000 1100	CLK12 interrupt in-service.				
1000 1101	CLK13 interrupt in-service.				
1000 1110	CLK14 interrupt in-service.				
1000 1111	CLK15 interrupt in-service.				

10 Error Reporting and Interrupt Control (continued)

10.2 Error Reporting and Interrupt Controller Circuit Operation

T8110L errors are reported via two output signals, CLKERR and SYSERR. These outputs are generated by an interrupt controller circuit; refer to Figure 20. The interrupt control circuit accepts 48 interrupt inputs in all. The way in which these interrupts are arbitrated is selectable, and the means of reporting the interrupts out to the system is also selectable.

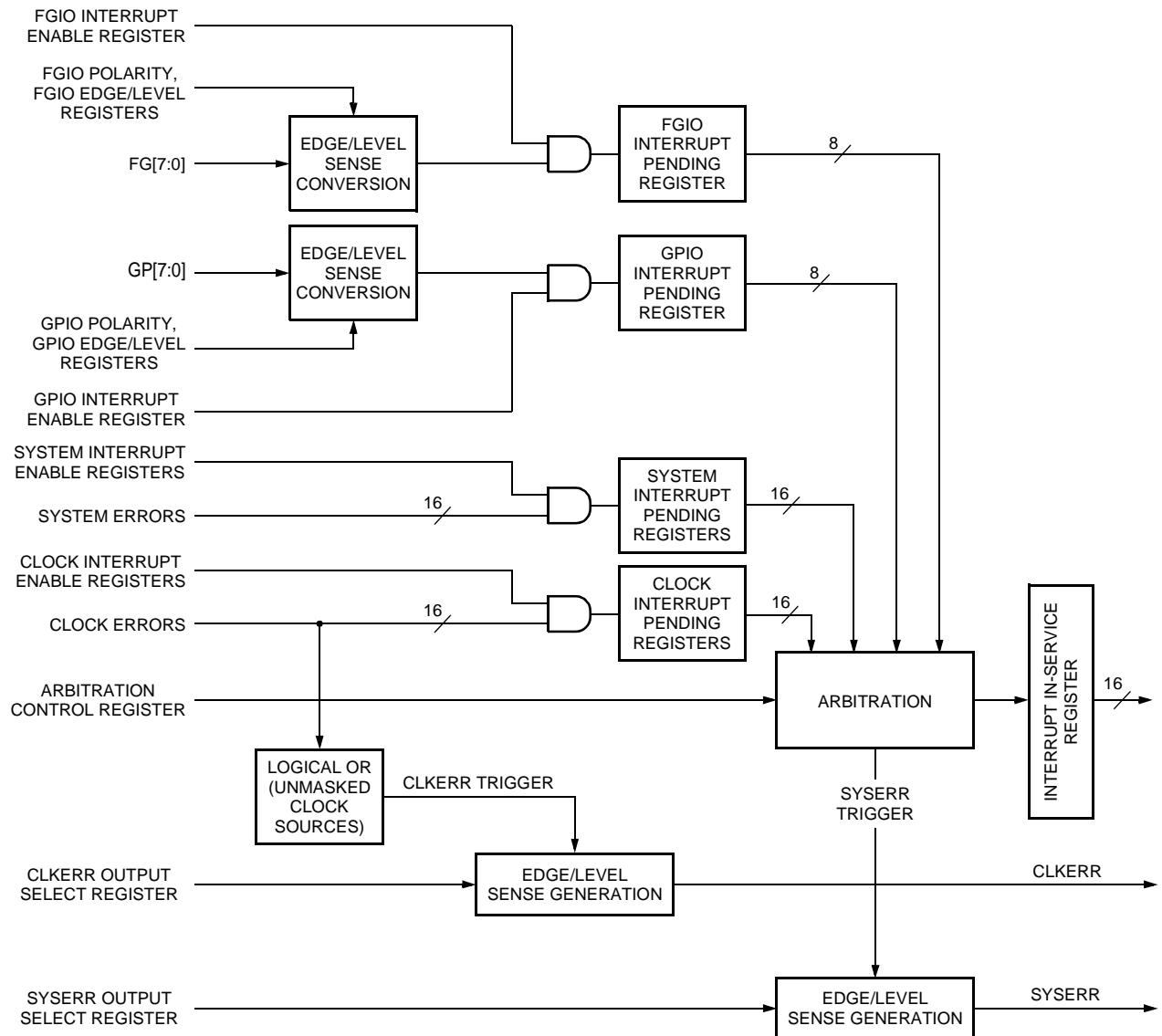

5-9425 (F)

Figure 20. Interrupt Controller

10 Error Reporting and Interrupt Control (continued)

10.2 Error Reporting and Interrupt Controller Circuit Operation (continued)

10.2.1 Externally Sourced Interrupts Via FG[7:0], GP[7:0]

Up to 16 of the 48 interrupt inputs are sourced external to the T8110L, via the FG[7:0] and GP[7:0] signals. Each input is independently controlled via the interrupt control registers (refer to Section 10.1.1 on page 90 and Section 10.1.2 on page 92). Any externally sourced interrupt may be presented as active-high level, active-low level, positive edge, or negative edge sense. Each external interrupt is maskable. Any detected interrupt which is unmasked is held in an interrupt pending register, and presented to the arbitration circuit for servicing.

10.2.2 Internally Sourced System Error Interrupts

Another set of 16 of the 48 interrupt inputs are sourced internally via the system error register bits (0x00126—127). Each of these inputs is independently controlled via the interrupt control registers (refer to Section 10.1.3 on page 93). All internal system error bit interrupts are presented as active-high level sense. Each system error bit interrupt is maskable. Any detected interrupt which is unmasked is held in an interrupt pending register and presented to the arbitration circuit for servicing.

10.2.3 Internally Sourced Clock Error Interrupts

Another set of 16 of the 48 interrupt inputs are sourced internally via the latched clock error register bits (0x00122—123; refer to Section 5.2.1 on page 40). Each of these inputs is independently controlled via the interrupt control registers (refer to Section 10.1.6 on page 96). All internal clock error bit interrupts are presented as active-high level sense. Each clock error bit interrupt is maskable. Any detected interrupt that is unmasked is held in an interrupt pending register and presented to the arbitration circuit for servicing.

10.2.4 Arbitration of Pending Interrupts

The arbitration of the pending interrupts can be handled in one of four selectable modes: arbitration off, flat arbitration, tier arbitration with pre-empting disabled, and tier arbitration with pre-empting enabled. Interrupts are reported to the system via the SYSERR signal.

10.2.4.1 Arbitration Off

This mode only allows the 16 internal system error register bits to generate interrupts, and no arbitration takes place. The trigger for the SYSERR output is simply a logical OR of the internal system error register bits. All bits of the internal system error register must be cleared in order to rearm the SYSERR trigger in this mode.

10.2.4.2 Flat Arbitration

The flat arbitration mode performs a round-robin arbitrations on all 48 interrupt sources. When a pending interrupt wins the arbitration, the in-service register is loaded with its corresponding interrupt vector, SYSERR is triggered, and that pending bit is cleared, removing it from the next round-robin arbitration cycle. The system must respond to the current in-service interrupt (refer to Section 10.2.7 on page 105), after which the next arbitration cycle takes place.

10.2.4.3 Tier Arbitration

The tier arbitration creates three prioritized groups as shown below:

- Highest priority. The 16 internal latched clock error register bits.
- Next highest priority. The 16 internal system error register bits.
- Lowest priority. The 16 external FG[7:0] and GP[7:0] bits.

10 Error Reporting and Interrupt Control (continued)

10.2 Error Reporting and Interrupt Controller Circuit Operation (continued)

10.2.4 Arbitration of Pending Interrupts (continued)

10.2.4.3 Tier Arbitration (continued)

Arbitration assigns interrupt servicing priority to the three groups. Multiple pending interrupts within the same group are arbitrated round-robin. When a pending interrupt wins the arbitration, the in-service register is loaded with its corresponding interrupt vector, SYSERR is triggered, and that pending bit is cleared, removing it from the next arbitration cycle.

10.2.4.4 Pre-Empting Disabled

With pre-empting disabled, once a pending interrupt wins the arbitration and the in-service register is loaded with its corresponding interrupt vector, new incoming pending interrupts of higher priority must wait for the system to respond to the current in-service interrupt (refer to Section 10.2.7 on page 105), at which time another arbitration cycle takes place.

10.2.4.5 Pre-Empting Enabled

With pre-empting enabled, an interrupt that is in-service (i.e., its interrupt vector is loaded in the in-service register and SYSERR has been triggered) can be overridden by new incoming pending interrupts of higher priority. The current in-service interrupt is pushed onto a stack for storage; the higher-priority interrupt vector is loaded into the in-service register and SYSERR is retriggered. Once all interrupts of higher priority have been serviced by the system (refer to Section 10.2.7 on page 105), the stack is popped and the original lower-priority interrupt is reissued.

10.2.5 CLKERR Output

The CLKERR output signal is used to indicate any internal clocking errors. The trigger for the CLKERR output is simply a logical OR of the internal latched clock error register bits. All bits of the internal clock error register must be cleared in order to rearm the CLKERR trigger. The CLKERR trigger induces a state machine to generate the CLKERR signal in one of four possible ways: active-high level, active-low level, active-high single pulse, or active-low single pulse.

10.2.6 SYSERR Output

The T8110L SYSERR output signal is used to report interrupts. Internally, the arbitration circuit provides a SYSERR trigger, which induces a state machine to generate the SYSERR signal in one of four possible ways: active-high level, active-low level, active-high single pulse, or active-low single pulse.

10.2.7 System Handling of Interrupts

The T8110L interrupt controller presents an interrupt to the system by triggering the SYSERR output and providing a predefined interrupt vector value at the interrupt in-service register (ISR). The system may acknowledge the interrupt in three ways as shown below:

- System reads the T8110L ISR register. This allows the arbiter to advance, and if more pending interrupts are active, reloads the ISR with the winner of the arbitration and retriggers SYSERR.
- System clears the T8110L ISR register (via register 0x00100, soft reset; write 0x20 clears the ISR). The arbiter advances, and if more pending interrupts are active, reloads the ISR and retriggers SYSERR.
- System resets the interrupt controller (via register 0x00100, soft reset; write 0x10 clears the ISR and all the pending interrupt registers). All pending interrupts are cleared, and the arbiter is reset.

11 Test and Diagnostics

11.1 Diagnostics Control Registers

The diagnostic control registers allow for various diagnostic modes (refer to Section 11.2 on page 112).

Table 87. Diagnostics Control Register Map

DWORD Address (20 bits)	Register			
	Byte 3	Byte 2	Byte 1	Byte 0
0x00140	Diag3, GP testpoint select	Diag2, GP testpoint enable	Diag1, FG testpoint select	Diag0, FG testpoint enable
0x00144	Diag7, external buffer RETRY timer	Diag6, miscellaneous diagnostics low	Diag5, state counter modes high	Diag4, state counter modes low
0x00148	Diag11, sync-to-frame command off-set high	Diag10, sync-to-frame command off-set low	Diag9, interrupt controller SYSERR delay	Diag8, interrupt controller diagnostics

11.1.1 FG Testpoint Enable Register

The FG testpoint enable register allows individual programming of FG[7:0] bits for either standard operation (as FG or FGIO) or as testpoint outputs. FG testpoint select controls the MUX selection for which testpoints are selected. Refer to Table 89 on page 107 for testpoint assignments for each FG bit.

Table 88. FG Testpoint Enable Registers

Byte Address	Name	Bit(s)	Mnemonic	Value	Function
0x00140	Diag0, FG Testpoint Enable	7	FT7EB	0 1	FG7 is standard FG or FGIO bit (default). FG7 is a testpoint.
		6	FT6EB	0 1	FG6 is standard FG or FGIO bit (default). FG6 is a testpoint.
		5	FT5EB	0 1	FG5 is standard FG or FGIO bit (default). FG5 is a testpoint.
		4	FT4EB	0 1	FG4 is standard FG or FGIO bit (default). FG4 is a testpoint.
		3	FT3EB	0 1	FG3 is standard FG or FGIO bit (default). FG3 is a testpoint.
		2	FT2EB	0 1	FG2 is standard FG or FGIO bit (default). FG2 is a testpoint.
		1	FT1EB	0 1	FG1 is standard FG or FGIO bit (default). FG1 is a testpoint.
		0	FT0EB	0 1	FG0 is standard FG or FGIO bit (default). FG0 is a testpoint.
0x00141	Diag1, FG Testpoint Select	7:0	FTPSR	LLLL LLLL	Value for MUX selection of testpoints output to FG[7:0]—see Table 88 on page 106.

11 Test and Diagnostics (continued)

11.1 Diagnostics Control Registers (continued)

11.1.1 FG Testpoint Enable Register (continued)

Table 89. FG[7:0] Internal Testpoint Assignments

FG Testpoint Select Value	FG7	FG6	FG5	FG4
0000 0001	i_FRAME	STATE_COUNT[10:4] (actual time slot)		
0000 0010	i_FRAME	STATE_COUNT_LOOKAHEAD (lookahead time slot)		
0000 0100	i_FRAME	STATE_COUNT_LOOKBEHIND (lookbehind time slot)		
0000 1000	Reserved	Reserved	Reserved	Reserved
0001 0000	Reserved	Reserved	Reserved	Reserved
0010 0000	Reserved			
0100 0000	P_S_SELECTOR	Reserved	OOL threshold flag	APLL1 lock indicator
1000 0000	Stalled	Snapping	C clock enable	B clock enable

—	FG3	FG2	FG1	FG0
0000 0001	STATE_COUNT[10:4] (actual time slot)			
0000 0010	STATE_COUNT_LOOKAHEAD (lookahead time slot)			
0000 0100	STATE_COUNT_LOOKBEHIND (lookbehind time slot)			
0000 1000	Reserved	Reserved	Reserved	Reserved
0001 0000	Reserved	Reserved	Reserved	Reserved
0010 0000	Reserved			
0100 0000	Failsafe flag	Force-to-OSC4 flag	Return from FS2 flag	Return from FS1 flag
1000 0000	A clock enable	Encoded ABC states: 000 or 100 = DIAGS 001 = A_ONLY 010 = A_MASTER 011 = A_ERROR 101 = B_ONLY 110 = B_MASTER 111 = B_ERROR		

11 Test and Diagnostics (continued)

11.1 Diagnostics Control Registers (continued)

11.1.2 GP Testpoint Enable Register

The GP testpoint enable register allows individual programming of GP[7:0] bits for either standard operation (as GPIO) or as testpoint outputs. GP testpoint select controls the MUX selection for which testpoints are selected. Refer to Table 91 on page 109 for testpoint assignments for each GP bit.

Table 90. Testpoint Enable Registers

Byte Address	Name	Bit(s)	Mnemonic	Value	Function
0x00142	Diag2, GP Testpoint Enable	7	GT7EB	0 1	GP7 is standard GPIO bit (default). GP7 is a testpoint.
		6	GT6EB	0 1	GP6 is standard GPIO bit (default). GP6 is a testpoint.
		5	GT5EB	0 1	GP5 is standard GPIO bit (default). GP5 is a testpoint.
		4	GT4EB	0 1	GP4 is standard GPIO bit (default). GP4 is a testpoint.
		3	GT3EB	0 1	GP3 is standard GPIO bit (default). GP3 is a testpoint.
		2	GT2EB	0 1	GP2 is standard GPIO bit (default). GP2 is a testpoint.
		1	GT1EB	0 1	GP1 is standard GPIO bit (default). GP1 is a testpoint.
		0	GT0EB	0 1	GP0 is standard GPIO bit (default). GP0 is a testpoint.
0x00143	Diag3, GP Testpoint Select	7:0	GTPSR	LLLL LLLL	Value for MUX selection of testpoints output to GP[7:0]—see Table 90 on page 108.

11 Test and Diagnostics (continued)

11.1 Diagnostics Control Registers (continued)

11.1.2 GP Testpoint Enable Register (continued)

Table 91. GP[7:0] Internal Testpoint Assignments

GP Testpoint Select Value	GP7	GP6	GP5	GP4
0000 0001	BYTEREF_16	BYTEREF_8	BYTEREF_4	BYTEREF_2
0000 0010	i_FRAME	Reserved	CP8 read	CP8 write
0000 0100	Reserved			
0000 1000	Reserved	Reserved	Reserved	Reserved
0001 0000	Reserved	Reserved	Reserved	Reserved
0010 0000	DPLL2 lock	DPLL1 lock	Reserved	
0100 0000	P_S_SELECTOR	Fallback encoded states: 000 = PRIMARY 001 = TO_PRIMARY 010 = SECONDARY 011 = TO_SECONDARY 100 = FS1 101 = FS2 110 = [reserved] 111 = INITIAL		
1000 0000	Stalled	Snapping	Reserved	Reserved

—	GP3	GP2	GP1	GP0
0000 0001	STATE_COUNT[3:0] (stream)			
0000 0010	CP4 read	CP4 write	CP2 read	CP2 write
0000 0100	Reserved			
0000 1000	Reserved	Reserved	Reserved	Reserved
0001 0000	Reserved	Reserved	Reserved	Reserved
0010 0000	Reserved			
0100 0000	Fallback flag	Go_clocks indicator	CLEAR_FALLBACK indicator	FORCE_FALLBACK indicator
1000 0000	Phase alignment frame event	APLL1 feedback, 8 MHz tap	APLL1 feedback, 4 MHz tap	APLL1 feedback, 2 MHz tap

11 Test and Diagnostics (continued)

11.1 Diagnostics Control Registers (continued)

11.1.3 State Counter Modes Registers

The state counter modes registers control state counter diagnostics, including the breaking of state counter carry chains, using /FR_COMP as the internal frame reference, and allowing the state counter to roll over early via a modulo function. For more details, refer to Section 11.2 on page 112.

Table 92. State Counter Modes Registers

Byte Address	Name	Bit(s)	Mnemonic	Value	Function
0x00144	Diag4, State Counter Modes Low	7:0	SCMLR	LLLL LLLL	Lower 8 bits of state counter modulo load value.
0x00145	Diag5, State Counter Modes High	7:6	Reserved	00	NOP (default).
		5	SCMSB	0 1	Normal carry chain operation (default). Break state counter carry chains.
		4	FRMSB	0 1	Normal internal frame operation (default). Use /FR_COMP as internal frame.
		3	SCLSB	0 1	Normal counting (default). State counter modulo counting.
		2:0	SCULP	LLL	Upper 3 bits of state counter modulo load value.

11.1.4 Miscellaneous Diagnostics Low Register

The miscellaneous diagnostics low register: bits 2 and 1 allow direct reset of the APLL2 and APLL1 feedback dividers. Bit 0 controls the TST input of the power-on reset cell.

Table 93. Miscellaneous Diagnostics Low Register

Byte Address	Name	Bit(s)	Mnemonic	Value	Function
0x00146	Diag6, Miscellaneous Diagnostics Low	7:3	Reserved	00	NOP (default).
		2	FB2SB	0 1	APLL2 feedback divider reset inactive (default). APLL2 feedback divider reset active.
		1	FB1SB	0 1	APLL1 feedback divider reset inactive (default). APLL1 feedback divider reset active.
		0	Reserved	—	—

11 Test and Diagnostics (continued)

11.1 Diagnostics Control Registers (continued)

11.1.5 Miscellaneous Diagnostic Registers

Table 94. Miscellaneous Diagnostic Registers

Byte Address	Name	Bit(s)	Mnemonic	Value	Function
0x00147	Diag7	7:0	Reserved	—	NOP.
0x00148	Diag8, Interrupt Controller Diagnostic	7:6	ICDSP	00 01	Interrupt controller, normal mode (default). Interrupt controller, DIAG mode.
		5:4	ICKLP	LL	DIAG mode, force CLK[1:0] errors.
		3:2	ISYLP	LL	DIAG mode, force SYS[1:0] errors.
		1:0	IEXLP	LL	DIAG mode, force EXT[8, 0] errors.
0x00149	Diag9, Interrupt Controller Deassertion Delay	7:0	IASLR	LLLL LLLL	Programmable delay to control the deassertion time of SYSERR.
0x0014A	Diag10, Sync-to-frame Command Delay (Lower)	7:0	CFLLR	LLLL LLLL	Low byte of 12-bit offset value for sync-to-frame clock commands (GO_CLOCKS, CLEAR_FALLBACK, FORCE_FALLBACK).
0x0014B	Diag11, Sync-to-frame Command Delay (Upper)	7:4	CFSEN	0000 0001	Disable delay mode (default). Enable delay mode.
		3:0	CFHLN	LLLL	Upper 4 bits of 12-bit offset value for sync-to-frame clock commands (GO_CLOCKS, CLEAR_FALLBACK, FORCE_FALLBACK).

11 Test and Diagnostics (continued)

11.2 Diagnostic Circuit Operation

The T8110L internal diagnostic modes are intended primarily for chip manufacturing test. The diagnostic functions include the following:

- DIAG0—3, observability of internal testpoints via FG(7:0), GP(7:0):
 - Internal testpoints are brought to chip I/O at FG and GP signals. Refer to Table 89 on page 107 and Table 91 on page 109 for testpoint assignment.
- DIAG4—5, internal state counter diagnostic modes:
 - Break counter carry chains—this is used in conjunction with monitoring of the state counter bits at FG and GP, and breaks the 11-bit state counter into three separate pieces (bits [10:8], [7:4] and [3:0]).
 - Shorten frame operation—the internally generated 8 kHz frame is bypassed in favor of the /FR_COMP input. The /FR_COMP input still denotes the frame center and may be presented at a higher frequency than 8 kHz. This is used in conjunction with the state counter modulo function, which when properly programmed allows the internal state counter to roll over coincident with the /FR_COMP frame center.
- DIAG6, forced RESET of analog APLL1 feedback dividers:
 - The APLL1 feedback dividers are typically not reset. This diagnostic mode allows each feedback divider to be held in a reset state.
- DIAG7, reserved.
- DIAG8, interrupt controller diagnostics:
 - When the diagnostic mode is enabled (DIAG8 register, bits 7:6 = 01), then bits 5:4 override the CLK error[1:0] inputs, bits [3:2] override the SYS error[1:0] inputs, bit 1 overrides the GP[0] input, and bit 0 overrides the FG[0] input to the interrupt controller. This allows for direct manipulation to set/clear a portion of interrupt bits from each tier group. Please see Section 10.2 on page 103 for more details.
- DIAG9, interrupt controller deassertion delay:
 - Allows a programmable deassertion time for the SYSERR signal in between back-to-back interrupts.
- DIAG10—11, sync-to-frame command delay:
 - Allows a programmable delay time from the FRAME boundary for execution of the sync-to-frame clock commands, GO_CLOCKS, CLEAR_FALLBACK, FORCE_FALLBACK.

12 Connection Control

12.1 Programming Interface

Programming the T8110L for time-slot switching requires specific access cycles to the connection memory regions. Access to other regions (data memory or registers) is made through a standard direct access via the interface.

12.1.1 Connection Memory Programming

Because the microprocessor interface only allows word or byte accesses, multiple write accesses must occur. For byte access, there are a total of three byte-wide holding registers. For word access, there is one word-wide holding register. The user must load the holding registers with the proper information first, and then write to the upper byte (or upper word) to actually move data into the connection memory; refer to Table 95.

The connection memory is divided into four 2K regions, each of which handles up to 128 time slots worth of connectivity for each of 16 serial data streams. The regions include H1x0 even streams (CT_D[30, 28, . . . 0]), H1x0 odd streams (CT_D[31, 29, . . . 1]), local low streams (L_D[15:0]), and local high streams (L_D[31:16]). The connection memory locations are addressed relative to time slot and stream.

Connection memory commands are as follows:

- RESET PAGE resets any (up to all four) connection memory region (see Figure 21 on page 114). Address bit 15 determines whether or not it's a reset page command. The reset page command relies on a valid internal chip clock and loops through all addresses within the connection memory region, resetting the VALID bit field. The RESET PAGE command is presented as either two microprocessor WORD writes, or four microprocessor BYTE writes, see Table 95.
- MAKE/BREAK/QUERY, telephony connection (see Figure 22 on page 114).

The MAKE and BREAK commands are presented as multiple microprocessor write cycles. The QUERY command is presented as multiple microprocessor read cycles; refer to Table 95.

Table 95. Microprocessor Programming, Connection Memory Access

Word/Byte (WB_SEL)	A[1:0]	D[15:8]	D[7:0]	Access Description
Byte	00	X	Data byte 0	Write data byte 0 to a holding register, or read data byte 0 information.
Byte	01	X	Data byte 1	Write data byte 1 to a holding register, or read data byte 1 information.
Byte	10	X	Data byte 2	Write data byte 2 to a holding register, or read data byte 2 information.
Byte	11	X	Data byte 3	Write data byte 3 plus the holding register data to connection memory, or read data byte 3 information.
Word	0X	Data byte 1	Data byte 0	Write data bytes 1 and 0 to a holding register, or read data bytes 1 and 0 information.
Word	1X	Data byte 3	Data byte 2	Write data bytes 3 and 2 plus the holding register data to connection memory, or read data bytes 3 and 2 information.

Note: Data byte n required information is shown in Figure 22.

12 Connection Control (continued)

12.1 Programming Interface (continued)

12.1.1 Connection Memory Programming (continued)

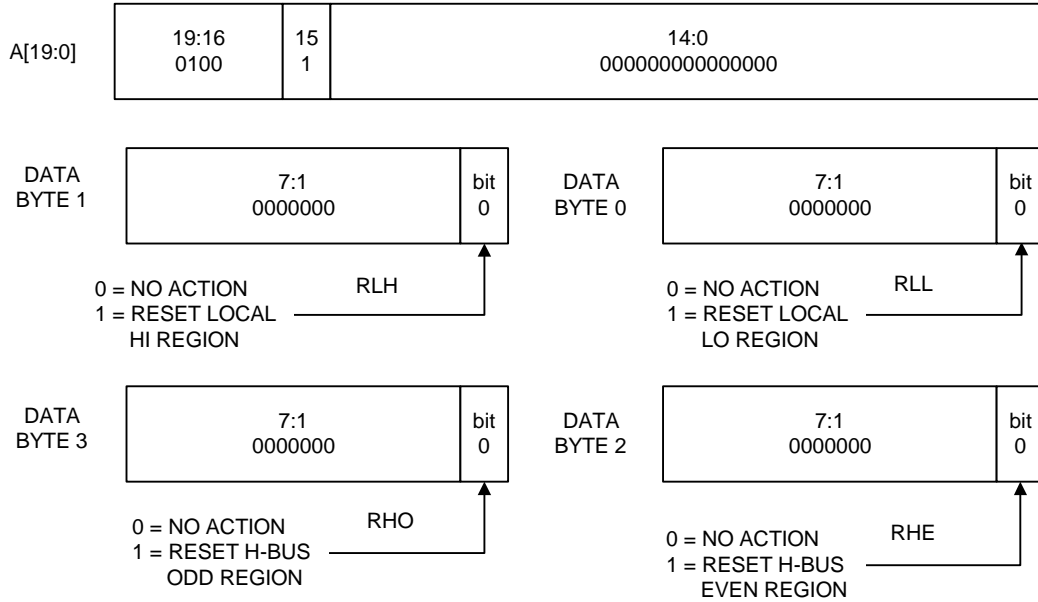

Figure 21. Microprocessor Programming—Reset Page Command

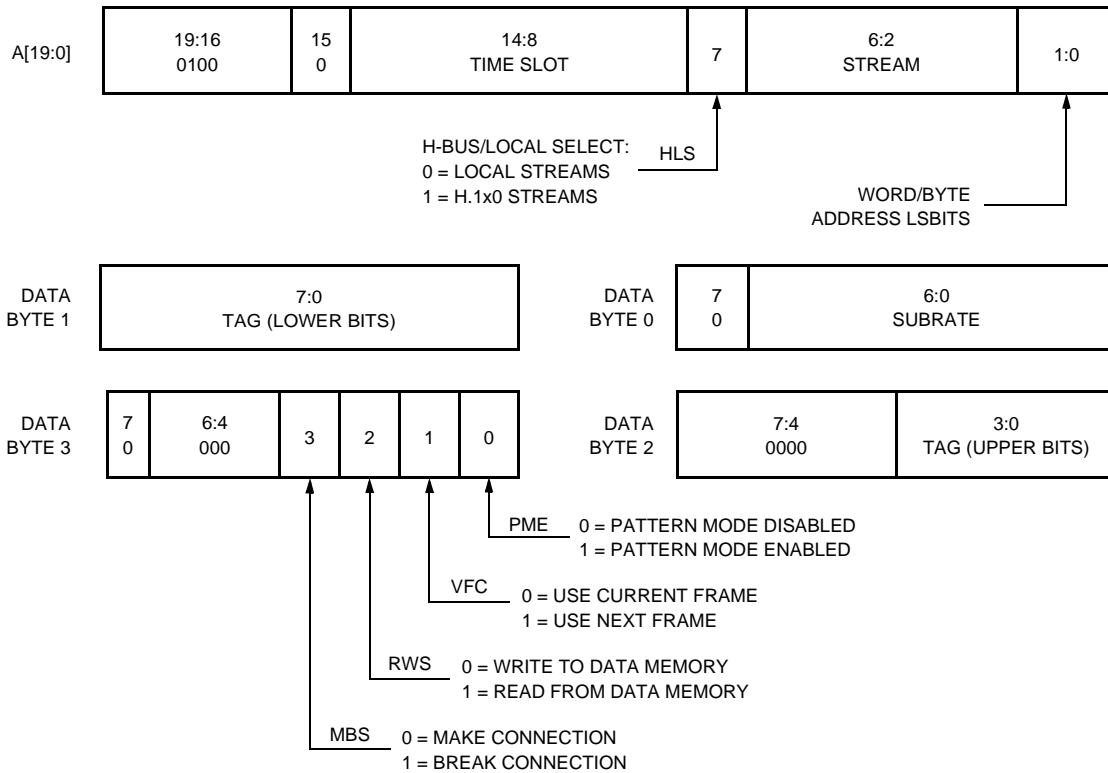

Figure 22. Microprocessor Programming—Make/Break/Query Telephony Connections

5-9632 (F)

12 Connection Control (continued)

12.2 Switching Operation

The basic building block of switching is one-half simplex connections loaded into the connection memory. Each connection memory location controls data flow, either from a serial stream input to a location in data memory, or from data memory to a serial stream output. A typical telephony simplex switch connection would use one **from** and one **to** connection, each using the same data memory location.

12.2.1 Memory Architecture and Configuration

12.2.1.1 Connection Memory

The T8110L connection memory consists of 8192 locations, one location for each of the possible stream/time-slot combinations, to provide a full nonblocking switch for up to 128 time slots on 32 H1x0 streams (CT_D[31:0]) and 32 local streams (L_D[31:0]). Connection memory is physically addressed by time slot (7 bits), H1x0/local select (1 bit), and stream (5 bits).

The 8192 locations are divided into four pages of 2048, with each page dedicated to a set of 16 serial streams as follows:

- H1x0 even streams (CT_D[30, 28, . . . 0])
- H1x0 odd streams (CT_D[31, 29, . . . 1])
- Local high streams (L_D[31:16])
- Local low streams (L_D[15:0])

Each of these connection memory pages are initialized at reset (valid bit entries are reset to invalid). Additionally, each page may be initialized individually via software command, RESET PAGE (refer to Figure 21 on page 114).

Connection memory locations contain the following control information:

- VALID bit indicates that a valid switch connection exists for this stream/time slot.
- RWS indicates whether the connection is **from** (from serial stream to data memory) or **to** (from DATA memory to serial stream).
- VFC (virtual framing control) controls which data page is used in double-buffer scenarios.
Note: There are two data memory configurations that allow double-buffering of the data, in order to create constant frame delay connections. Refer to Section 12.2.1.2 on page 116 and Section 12.2.2.1 on page 117.
- PME indicates a pattern mode connection.
- TAG is the data memory location used for this one-half simplex switch connection (or the data pattern sent to serial output for pattern mode connections).
- SUBRATE information is subrate switching control (bitswap).

12 Connection Control (continued)

12.2 Switching Operation (continued)

12.2.1 Memory Architecture and Configuration (continued)

12.2.1.2 Data Memory

The T8110L data memory is 4096 bytes, which can be programmatically configured in three ways, via the data memory mode select register (0x00105; refer to Section 5.1.3 on page 32).

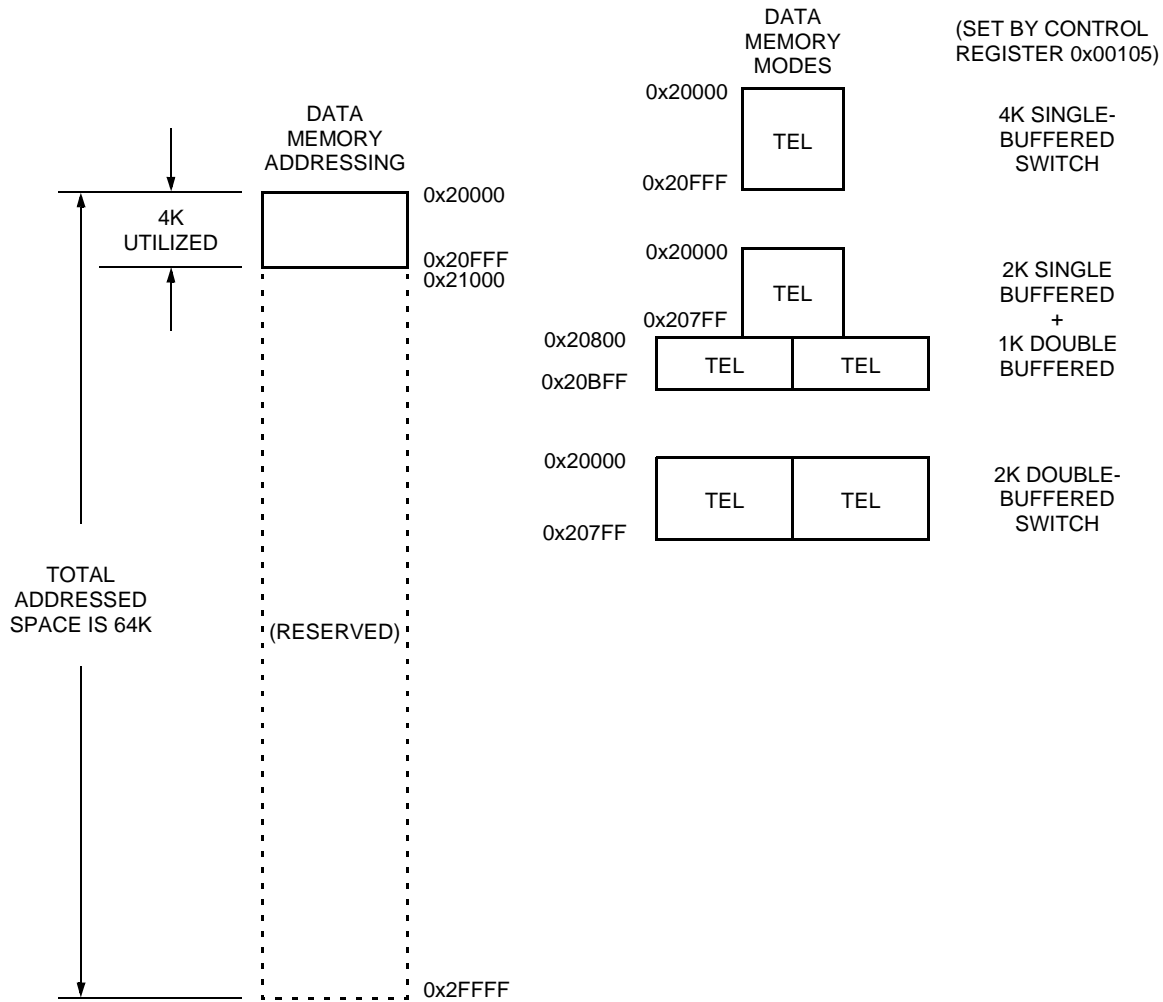

5-9638 (F)

Figure 23. T8110L Data Memory Map and Configurations

12 Connection Control (continued)

12.2 Switching Operation (continued)

12.2.2 Standard Switching

Standard telephony switching is achieved by loading control fields into the connection memory for one-half simplex connections (refer to Figure 22 on page 114, and Section 12.2.1.1 on page 115).

12.2.2.1 Constant Delay and Minimum Delay Connections

The VFC control bit in connection memory determines which of two data pages is accessed, when the data memory is configured to double-buffering for telephony connections (refer to Figure 23). This bit always affects **to** connections (read the data memory, send it out to a serial stream output) in a double-buffer configuration. This bit can control a **from** connection in a double-buffer configuration, only if it is a subrate connection; otherwise, the VFC bit has no bearing on **from** connections.

The double-buffering configuration creates two data pages. During a particular frame (125 μ s time boundary, partitioned into time slots), one page is the active page, the other is the inactive page. The active/inactive page status toggles at every frame boundary. For all **from** connections (except for subrate connections), incoming serial data is always written to the active page. For all **to** connections, the VFC control bit indicates whether to read from the active or inactive page. Manipulation of this bit affects the latency between the incoming **from** data and the outgoing **to** data. This latency defines whether or not a connection is constant delay or minimum delay.

Please see Appendix A on page 139 for more details on constant and minimum delay connections.

12.2.2.2 Pattern Mode

The PME control bit in connection memory affects only **to** connections. Instead of reading a value out of the data memory for subsequent output to a serial stream, the lower 8 bits of the TAG field provide a byte pattern for the serial output.

12.2.2.3 Subrate

The subrate control bit field in connection memory is used only by **from** connections and controls how individual bits or groups of bits of an incoming serial byte are shuffled prior to writing them to the data memory, in order to achieve subrate switching.

12 Connection Control (continued)

12.2 Switching Operation (continued)

12.2.2 Standard Switching (continued)

12.2.2.1 Subrate (continued)

Subrate Switching Overview

Traditional byte-oriented TDM data switching provides 8 bits of data per time slot, or channel, regardless of the TDM stream bit rate. A particular channel occurs once every 8 kHz frame, and there are 8K frames per second. This allows for a channel data propagation rate of (8 bits/frame * 8K frames/s = 64 kbits/s).

Refer to Figure 24 and Table 97.

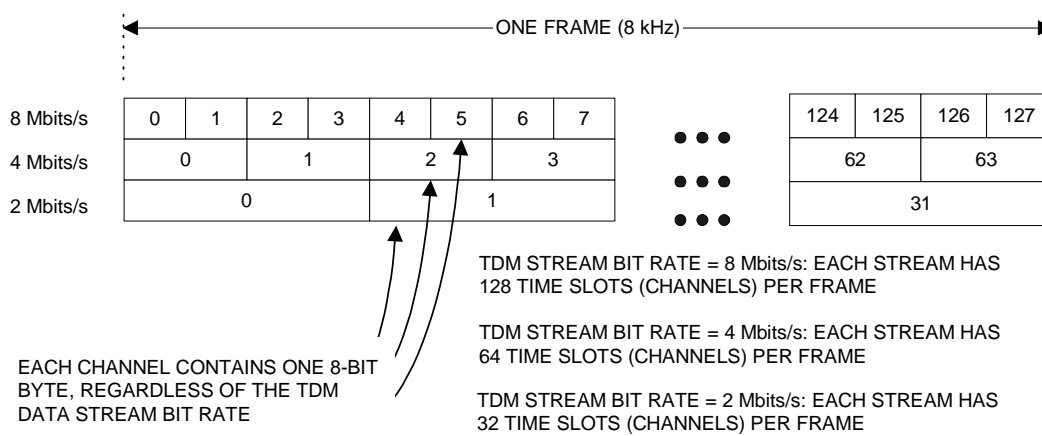

Figure 24. TDM Data Stream Bit Rates

Subrate refers to switching fractional portions of the byte-oriented TDM data streams. The T8110L allows the 8 bits of a byte-oriented channel to be broken into multiple channels of fewer bits, either two 4-bit channels, four 2-bit channels, or eight 1-bit channels. This lowers the data propagation rate per channel, but increases the overall channel capacity for a given time slot. Refer to Table 96 and Table 97.

Table 96. TDM Data Stream

		One Time slot (or Channel)							
Bit		7	6	5	4	3	2	1	0
Di-Bit		7:6		5:4		3:2		1:0	
Nibble		7:4				3:0			
Byte		7:0							

Notes:
 Bit subrate = 8 channels per time slot, 1 bit per channel.
 Di-bit = 4 channels per time slot, 2 bits per channel.
 Nibble subrate = 2 channels per time slot, 4 bits per channel.
 Byte (no subrate) = 1 channel per time slot, 8 bits per channel.

12 Connection Control (continued)

12.2 Switching Operation (continued)

12.2.2 Standard Switching (continued)

12.2.2.1 Subrate (continued)

Subrate Switching Overview (continued)

Table 97. Subrate Switching, Data Propagation Rate vs. Channel Capacity

Subrate Type	Bits per Channel	Channel Data Propagation Rate (Bits/Frame x 8K Frames/s)	Channel Capacity (Relative to Byte Switching)
Bit	1	8 kbits/s	8X
Di-bit	2	16 kbits/s	4X
Nibble	4	32 kbits/s	2X
Byte (no subrate)	8	64 kbits/s	1X

Subrate Switching Using T8110L

The H1x0 bus and the local stream bus are based on byte-oriented TDM data streams—data is always switched as whole bytes. The subrate data must be packed into these bytes prior to switching (refer to Sections and). The data bytes are not necessarily constrained to using fully packed bytes—any portion of a byte may be used. Subrate switching using T8110L requires the following:

- Overall subrate enable mode is activated (register 0x00105, data memory mode select bit 7 is set; see Section 5.1.3 on page 32).
- The subrate field of the connection memory entry for that switch connection is set up. This field contains 7 bits which control the type of subrate (i.e., bit, di-bit, nibble, or byte), and the data bit shuffling within the TDM byte data, **from** and **to** (refer to Figure 22 on page 114, and Table 98).
- The VFC connection memory bit for cases where a double-buffering configuration is set up in the data memory (refer to Figure 22, and Sections 12.2.1.2, 12.2.2.1).

In order to program a subrate simplex connection, the subrate field is only required for the **from** half of that connection. Incoming serial byte data has its bit positions rearranged based on the subrate field contents prior to being written into the data memory. For double-buffered data memory configurations, the VFC bit controls which of two data pages the rearranged byte is written to. The **to** half of a subrate simplex connection simply outputs the entire byte found at the data memory location used for that connection, and its connection memory subrate field is ignored.

12 Connection Control (continued)

12.2 Switching Operation (continued)

12.2.2 Standard Switching (continued)

12.2.2.1 Subrate (continued)

Subrate Switching Using T8110L (continued)

Table 98. Subrate Switching, Connection Memory Programming Setup

Subrate Type	Subrate Connection Memory Bit Field (6:0)						
	6	5	4	3	2	1	0
Bit	1	000 = from bit 0 001 = from bit 1 010 = from bit 2 011 = from bit 3 100 = from bit 4 101 = from bit 5 110 = from bit 6 111 = from bit 7				000 = to bit 0 001 = to bit 1 010 = to bit 2 011 = to bit 3 100 = to bit 4 101 = to bit 5 110 = to bit 6 111 = to bit 7	
	Subrate Connection Memory Bit Field (6:0)						
	6	5	4	3	2	1	0
Di-Bit	01		00 = from bits[1:0] 01 = from bits[3:2] 10 = from bits [5:4] 11 = from bits[7:6]		Reserved	00 = to bits[1:0] 01 = to bits[3:2] 10 = to bits[5:4] 11 = to bits[7:6]	
Subrate Type	Subrate Connection Memory Bit Field (6:0)						
	6	5	4	3	2	1	0
Nibble	001			0 = from bits[3:0] 1 = from bits[7:4]	Reserved		0 = to bits[3:0] 1 = to bits[7:4]
	Subrate Connection Memory Bit Field (6:0)						
	6	5	4	3	2	1	0
Byte	000			Reserved			

Subrate Packing of Outgoing Bytes

The output from subrate connections is always an entire byte so that it does not violate the H.100 or H.110 specifications. The output byte is composed of smaller, i.e., subrate pieces. The process of combining the incoming pieces into a whole byte suitable for output is called **packing**. In the T8110L (and other subrate-capable *Ambassador* devices), **packing** is accomplished by making several **from** connections for each single **to** connection. For example, in Figure 25, four **from** connections (of different stream/time-slot origins), all di-bits, are used to construct a byte that will be output as defined by the **to** connection.

The outgoing **to** half of a simplex connection reads an entire byte from a data memory location. The packing of separate incoming subrate pieces into this byte is achieved by setting up multiple **from** one-half simplex connections for one **to** one-half simplex connection, all using the same data memory location. An example is illustrated in Figure 25. This example shows the packing of four separate incoming di-bits from four different channels into one outgoing byte on one channel.

Note: Please note the limitation that multiple di-bits from the same time slot cannot be switched simultaneously. This would require the byte of that time slot to be unpacked first, which is discussed in Section on page 122.

12 Connection Control (continued)

12.2 Switching Operation (continued)

12.2.2 Standard Switching (continued)

12.2.2.1 Subrate (continued)

Subrate Packing of Outgoing Bytes (continued)

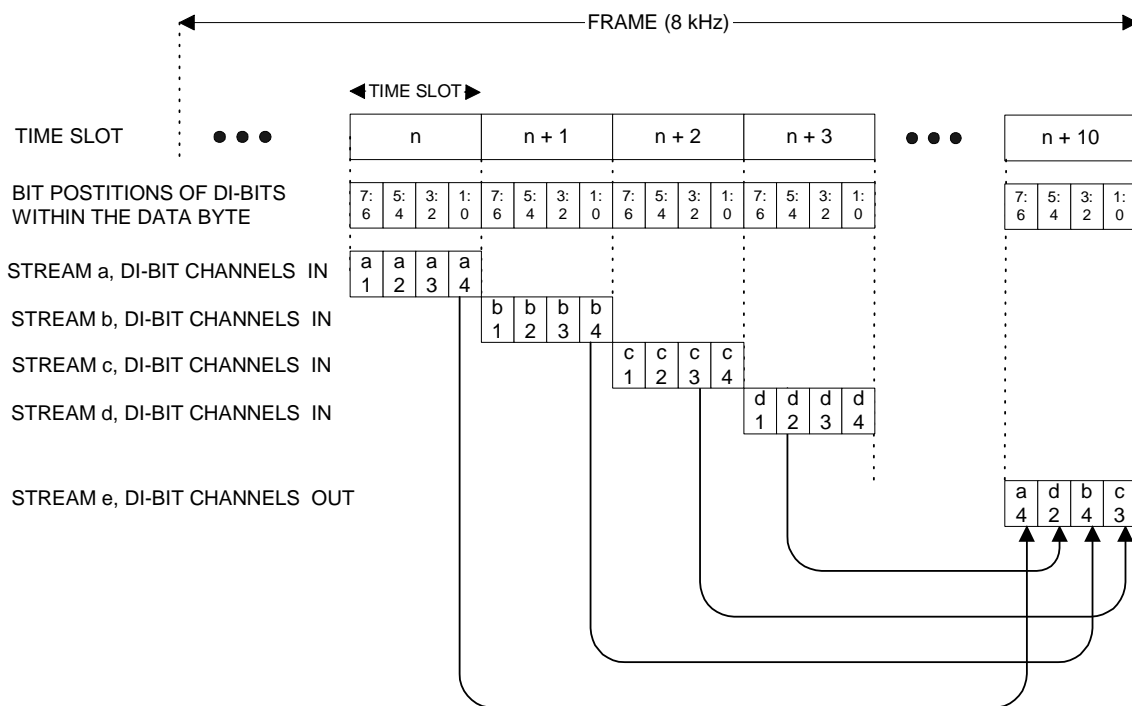

Notes:

Connectivity is as follows:

- From stream a, time slot n, bits[1:0] to stream e, time slot n + 10, bits[7:6].
- From stream b, time slot n + 1, bits[1:0] to stream e, time slot n + 10, bits[3:2].
- From stream c, time slot n + 2, bits[3:2] to stream e, time slot n + 10, bits[1:0].
- From stream d, time slot n + 3, bits[5:4] to stream e, time slot n + 10, bits[5:4].

Required connection memory programming is as follows:

Five 1/2 simplex connections are required to pack four incoming di-bits into an outgoing byte.

- From stream a, time slot n. Connection memory subrate field = 0100X11.
- From stream b, time slot n + 1. Connection memory subrate field = 0100X01.
- From stream c, time slot n + 2. Connection memory subrate field = 0101X00.
- From stream d, time slot n + 3. Connection memory subrate field = 0110X10.
- To stream e, time slot n + 10. Connection memory subrate field is don't care.

Figure 25. Subrate Switching Example, Byte Packing

12 Connection Control (continued)**12.2 Switching Operation** (continued)**12.2.2 Standard Switching** (continued)**12.2.2.1 Subrate** (continued)**Subrate Unpacking of Incoming Bytes**

Because the H1x0 bus and the local stream bus are based on byte-oriented TDM data streams, and the T8110L architecture is geared towards standard byte switching, it is not possible to simultaneously switch subrate portions of a single byte to different places. This limitation is overcome by application. To gain access to each subrate piece contained in one incoming byte, that byte must be broadcast onto additional channels, one channel for each subrate piece required. The means of broadcasting is up to the application—either the source device of the packed subrate byte can broadcast it, or the device receiving that byte can broadcast it over unused channels and loop the broadcast bytes back in. The example from Figure 25 is extended in Figure 26. This example shows the unpacking of the packed byte created in Figure 25, output to four different channels.

12 Connection Control (continued)

12.2 Switching Operation (continued)

12.2.2 Standard Switching (continued)

12.2.2.1 Subrate (continued)

Subrate Unpacking of Incoming Bytes (continued)

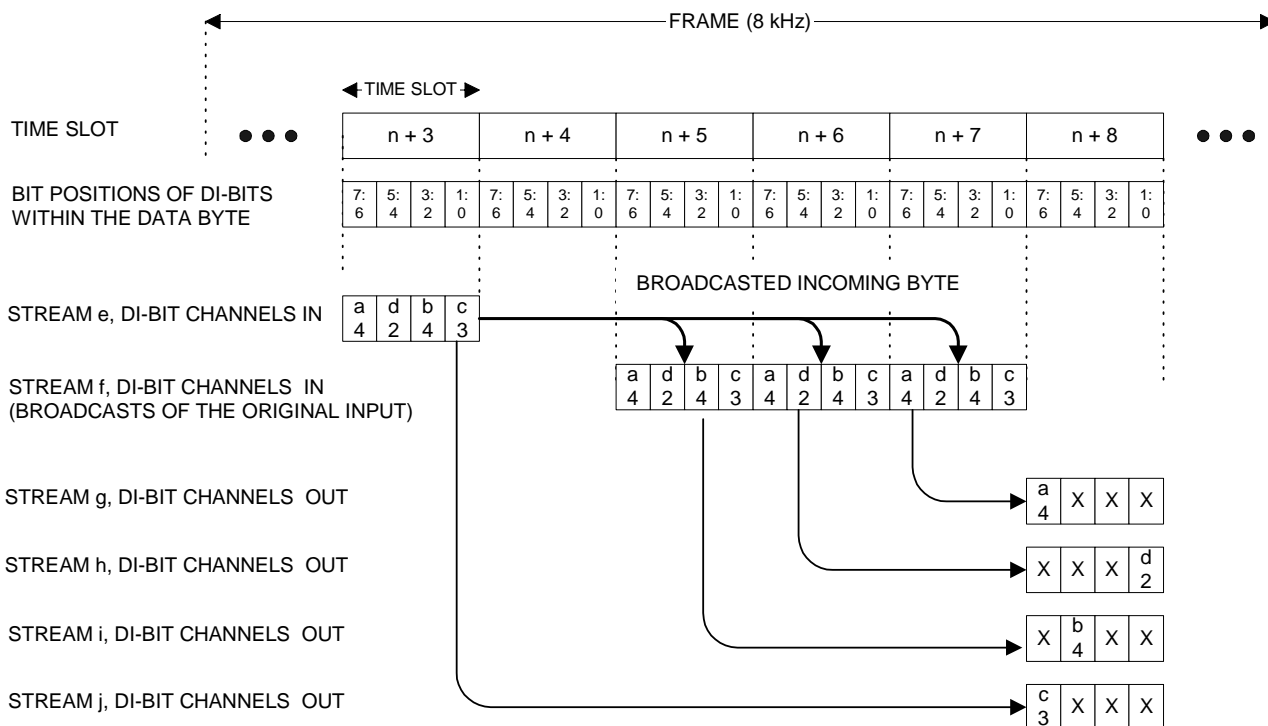

Notes:

Connectivity is as follows:

From stream e, time slot n + 3, bits[1:0] **to** stream j, time slot n + 8, bits[7:6].

From stream f, time slot n + 5, bits[3:2] **to** stream i, time slot n + 8, bits[5:4].

From stream f, time slot n + 6, bits[5:4] **to** stream h, time slot n + 8, bits[1:0].

From stream f, time slot n + 7, bits[7:6] **to** stream g, time slot n + 8, bits[7:6].

Required connection memory programming is as follows:

Eight 1/2 simplex connections are required to unpack one incoming byte to four separate outgoing di-bits.

From stream e, time slot n + 3. Connection memory subrate field = 0100X11.

From stream f, time slot n + 5. Connection memory subrate field = 0101X10.

From stream f, time slot n + 6. Connection memory subrate field = 0110X00.

From stream f, time slot n + 7. Connection memory subrate field = 0111X11.

To stream g, time slot n + 8. Connection memory subrate field is don't care.

To stream h, time slot n + 8. Connection memory subrate field is don't care.

To stream i, time slot n + 8. Connection memory subrate field is don't care.

To stream j, time slot n + 8. Connection memory subrate field is don't care.

Figure 26. Subrate Switching Example, Byte Unpacking

13 Electrical Characteristics

13.1 Absolute Maximum Ratings

Stresses in excess of the absolute maximum ratings can cause permanent damage; the table below shows absolute stress ratings only. Functional operation of the device is not implied at these or any other conditions in excess of those given in the operational sections of this data sheet. Exposure to absolute maximum ratings for extended periods can adversely affect device reliability.

Table 99. Absolute Maximum Ratings

Parameter	Symbol	Min	Max	Unit
Supply Voltage	V _{DD}	—	4.2	V
XTAL1_IN, XTAL2_IN, XTAL1_OUT, XTAL2_OUT pins	—	V _{SS}	V _{DD}	V
Voltage Applied to I/O Pins	—	V _{SS} – 0.3	V _{DD} 5.5	V
Operating Temperature	—	–40	85	°C
Storage Temperature	T _{stg}	–55	125	°C

13.1.1 Handling Precautions

Although protection circuitry has been designed into this device, proper precautions should be taken to avoid exposure to electrostatic discharge (ESD) during handling and mounting. Agere employs a human-body model (HBM) and a charged-device model (CDM) for ESD-susceptibility testing and protection design evaluation. ESD voltage thresholds are dependent on the circuit parameters used to define the model. No industry-wide standard has been adopted for CDM. However, a standard HBM (resistance = 1500 W, capacitance = 100 pF) is widely used and, therefore, can be used for comparison purposes. The T8110L has a HBM ESD threshold voltage rating of 1500 V minimum.

13.2 Crystal Specifications

13.2.1 XTAL1 Crystal

The T8110L requires a 16.384 MHz clock source derived from an oscillator or a crystal. If a crystal is used it has to be a 16.384 MHz crystal and must be connected between the XTAL1_IN and the XTAL1_OUT pins. External 24 pF, 5% capacitors must be connected from XTAL1_IN and XTAL1_OUT to V_{SS}, as shown in the diagram below. The ±32 ppm tolerance is the suggested value if the oscillator is used as the clocking source while mastering the bus. Otherwise, a crystal with a lesser tolerance can be used. The crystal specifications are shown below.

Table 100. XTAL1 Specifications

Parameter	Value
Frequency	16.384 MHz
Oscillation Mode	Fundamental, parallel resonance
Effective Series Resistance	50 Ω maximum
Load Capacitance	18 pF
Shunt Capacitance	7 pF maximum
Frequency Tolerance and Stability	32 ppm

5-6390f(c)

13 Electrical Characteristics (continued)

13.2 Crystal Specifications (continued)

13.2.1 XTAL1 Crystal (continued)

If an oscillator is used (see Section 6.4.4 on page 61), the signal has to be connected to the XTAL1_IN pin. XTAL1_OUT must be left unconnected in this configuration. XTAL1_IN and XTAL1_OUT are not 5 V tolerant. The oscillator must meet the requirements shown below.

Table 101. 16.384 MHz Oscillator Requirements

Parameter	Value	
Frequency	16.384 MHz	
Maximum Rise or Fall Time	10 ns, 10%—90% V _{DD}	
Minimum Pulse Width	Low	High
	20 ns	20 ns

13.2.2 XTAL2 Crystal

XTAL2 is an optional crystal oscillator input. If a crystal is used, it has to be a 6.176 MHz or a 12.352 MHz crystal and must be connected between the XTAL2_IN and the XTAL2_OUT pins, as shown in the diagram below. External 24 pF, 5% capacitors must be connected from XTAL2_IN and XTAL2_OUT to V_{SS}. The ±32 ppm tolerance is the suggested value if the oscillator is used as the clocking source while mastering the bus. Otherwise, a crystal with a lesser tolerance can be used (see Table 121).

If XTAL2 is not used, XTAL2_IN should be tied to V_{DD} and XTAL2_OUT should be left unconnected.

Table 102. XTAL2 Specifications

Parameter	Value
Frequency	12.352 MHz
Oscillation Mode	Fundamental, parallel resonance
Effective Series Resistance	75* Ω maximum
Load Capacitance	18‡ pF
Shunt Capacitance	7 pF maximum
Frequency Tolerance and Stability	32 ppm

5-6390d

* 120 Ω maximum for 6.176 MHz crystal.

† 24 pF for 6.176 MHz crystal also.

‡ 18 pF for 6.176 MHz crystal also.

If an oscillator is used (see Section 6.5.1 on page 63), the signal has to be connected to the XTAL2_IN pin. XTAL2_OUT must be left unconnected in this configuration. XTAL2_IN and XTAL2_OUT are not 5 V tolerant. The oscillator must meet the requirements shown below.

Table 103. 6.176 MHz/12.352 MHz Oscillator Requirements

Parameter	Value		Value	
	Frequency	6.176 MHz		12.352 MHz
Maximum Rise or Fall Time	10 ns, 10%—90% V _{DD}		10 ns, 10%—90% V _{DD}	
Minimum Pulse Width	Low	High	Low	High
	54 ns	54 ns	27 ns	27 ns

13 Electrical Characteristics (continued)**13.2 Crystal Specifications** (continued)**13.2.3 Reset Pulse****Table 104. Reset Pulse**

Parameter	Min	Max	Unit
RESET# Minimum Pulse Width	61	—	ns

13.3 Thermal Parameters (Definitions and Values)

System and circuit board level performance depends not only on device electrical characteristics, but also on device thermal characteristics. The thermal characteristics frequently determine the limits of circuit board or system performance, and they can be a major cost adder or cost avoidance factor. When the die temperature is kept below 125 °C, temperature activated failure mechanisms are minimized. The thermal parameters that Agere provides for its packages help the chip and system designer choose the best package for their applications, including allowing the system designer to thermally design and integrate their systems.

It should be noted that all the parameters listed below are affected, to varying degrees, by package design (including paddle size) and choice of materials, the amount of copper in the test board or system board, and system airflow.

Θ_{JA}—Junction to Air Thermal Resistance

Θ_{JA} is a number used to express the thermal performance of a part under JEDEC standard natural convection conditions. Θ_{JA} is calculated using the following formula:

$$\Theta_{JA} = (T_J - T_{amb})/P; \text{ where } P = \text{power}$$

Θ_{JMA}—Junction to Moving Air Thermal Resistance

Θ_{JMA} is effectively identical to Θ_{JA} but represents performance of a part mounted on a JEDEC four layer board inside a wind tunnel with forced air convection. Θ_{JMA} is reported at airflows of 200 lft./min and 500 lft./min, which roughly correspond to

1 m/s and 2.5 m/s (respectively). Θ_{JMA} is calculated using the following formula:

$$\Theta_{JMA} = (T_J - T_{amb})/P$$

Θ_{Jc}—Junction to Case Thermal Resistance

Θ_{Jc} is the thermal resistance from junction to the top of the case. This number is determined by forcing nearly 100% of the heat generated in the die out the top of the package by lowering the top case temperature. This is done by placing the top of the package in contact with a copper slug kept at room temperature using a liquid refrigeration unit. Θ_{Jc} is calculated using the following formula:

$$\Theta_{Jc} = (T_J - T_c)/P$$

13 Electrical Characteristics (continued)

13.3 Thermal Parameters (Definitions and Values) (continued)

Θ_{JB}—Junction to Board Thermal Resistance

Θ_{JB} is the thermal resistance from junction to board. This number is determined by forcing the heat generated in the die out of the package through the leads or balls by lowering the board temperature and insulating the package top. This is done using a special fixture, which keeps the board in contact with a water chilled copper slug around the perimeter of the package while insulating the package top. Θ_{JB} is calculated using the following formula:

$$\Theta_{JB} = (T_J - T_B)/P$$

Ψ_{JT}

Ψ_{JT} correlates the junction temperature to the case temperature. It is generally used by the customer to infer the junction temperature while the part is operating in their system. It is not considered a true thermal resistance. Ψ_{JT} is calculated using the following formula:

$$\Psi_{JT} = (T_J - T_C)/P$$

Table 105. Thermal Parameter Values

Parameter	Temperature °C/Watt
Θ _{JA}	22
Θ _{JMA} (1 m/s)	19
Θ _{JMA} (2.5 m/s)	17.5
Θ _{JC}	20
Θ _{JB}	TBD
Ψ _{JT}	1.0

13.4 Reliability

Product reliability can be calculated as the probability that the product will perform under normal operating conditions for a set period of time. Factors influencing the reliability of a product cover a range of variables, including design and manufacturing. The failure rate of a product is given as the number of units failing per unit time. This failure rate is known as FIT, which is as follows:

$$1 \text{ FIT} = 1 \text{ Failure}/1 \times 10^9 \text{ hours.}$$

Another unit used for failure rate is known as MTBF, which is 1/FIT. Many assumptions are made when calculating the failure rate for a product, such as the average junction temperature and activation energy. The assumptions made for calculating FIT and MTBF are shown in Table 106:

Table 106. Reliability Data

Junction Temperature	FIT (Per 10e ⁹ Device Hours)	MTBF	Activation Energy
55 °C	10	1.0e ⁸ hours	.7eV

13 Electrical Characteristics (continued)**13.5 dc Electrical Characteristics****13.5.1 Electrical Drive Specifications, CT_C8 and /CT_FRAME**

$V_{DD} = 3.3\text{ V}$ and $V_{SS} = 0.0\text{ V}$, unless otherwise specified.

Table 107. Electrical Drive Specifications, CT_C8 and /CT_FRAME

Parameter	Symbol	Condition	Min	Max	Unit
Output High Voltage	V_{OH}	$I_{OUT} = -24\text{ mA}$	2.4	3.3	V
Output Low Voltage	V_{OL}	$I_{OUT} = 24\text{ mA}$	-0.25	0.4	V
Positive-going Threshold	V_{t+}	—	1.2	2.0	V
Negative-going Threshold	V_{t-}	—	0.6	1.6	V
Hysteresis ($V_{t+} - V_{t-}$)	V_{HYS}	—	0.4	—	V
Input Pin Capacitance	C_{IN}	—	—	10	pF

PCI-compliant data line I/O cells are used for the CT bus data lines. (See *PCI Specification*, Rev. 2.2, Chapter 4.)

/C16, /C4, C2, SCLK, /SCLKx2, and /FR_COMP all use the same driver/receiver pairs as those specified for the CT_C8 and /CT_FRAME signals, though this is not explicitly stated as a part of the H.1x0 specification.

13 Electrical Characteristics (continued)

13.5 dc Electrical Characteristics (continued)

13.5.2 All Other Pins

V_{DD} = 3.3 V and V_{SS} = 0.0 V, unless otherwise specified.

Table 108. dc Electrical Characteristics, All Other Pins

Parameter	Symbol	Condition	Min	Typ	Max	Unit
Supply Current	I _{DD}	2000 H-bus/L-bus connections	—	300	—	mA
Supply Voltage	V _{DD}	—	3.0	—	3.6	V
Input High Voltage	V _{IH}	—	2.0	—	—	V
Input Low Voltage	V _{IL}	—	—	—	0.8	V
Input Current	I _I	—	—	—	1	μA
Input Capacitance (input only)	C _I	—	—	—	5	pF
Input Capacitance (I/O pins)	C _{IO}	—	—	—	10	pF
Leakage Current (3-state)	I _{LEAK}	—	—	—	10	μA
Input Clamp Voltage	V _C	—	—	—	-1.0	V
Output High Voltage	V _{OH}	I = 8 mA	2.4	—	—	V
Output Low Voltage	V _{OL}	I = 8 mA	—	—	0.4	V
Output Short-circuit Current	I _{OS}	V _{OH} tied to GND	—	—	100	mA

13.6 H-Bus Timing

13.6.1 Timing Diagrams

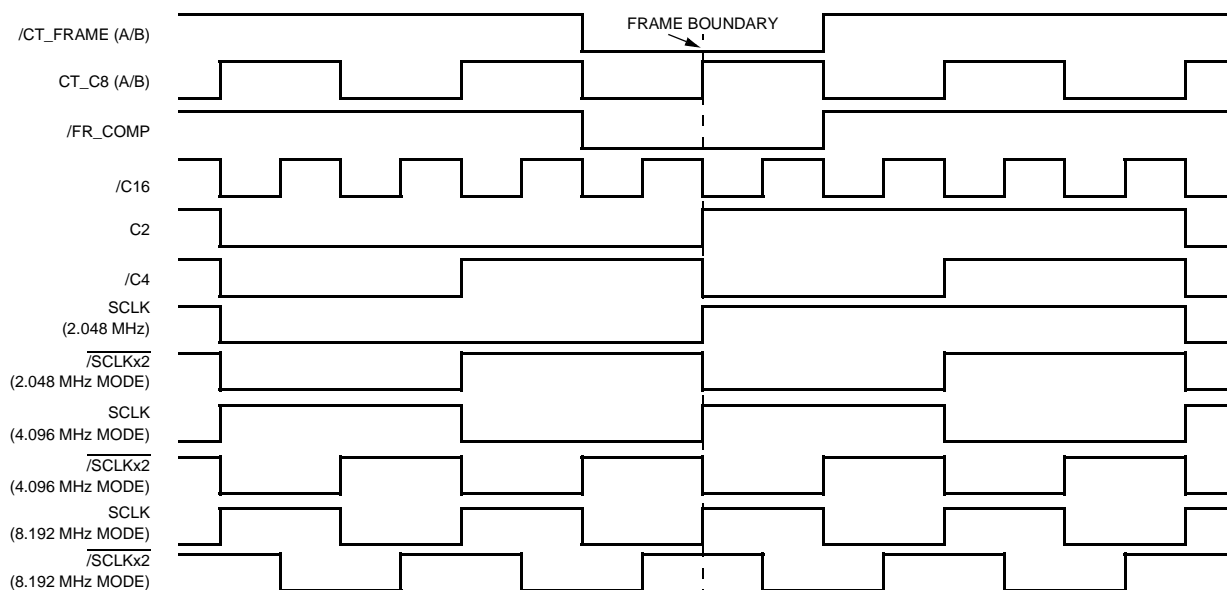

5-6119F

Figure 27. Clock Alignment

13 Electrical Characteristics (continued)

13.6 H-Bus Timing (continued)

13.6.1 Timing Diagrams (continued)

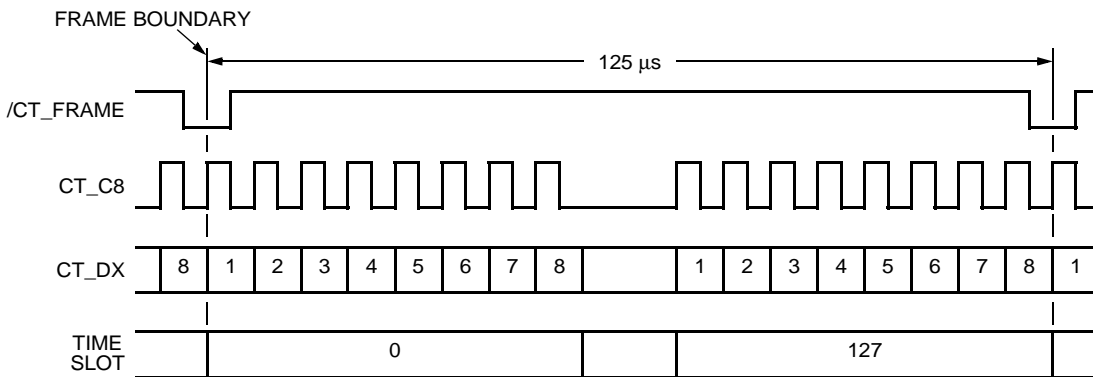

Note: Bit 1 is the MSB and Bit 8 is the LSB. MSB is always transmitted first in all transfers.

5-6120F

Figure 28. Frame Timing Diagram

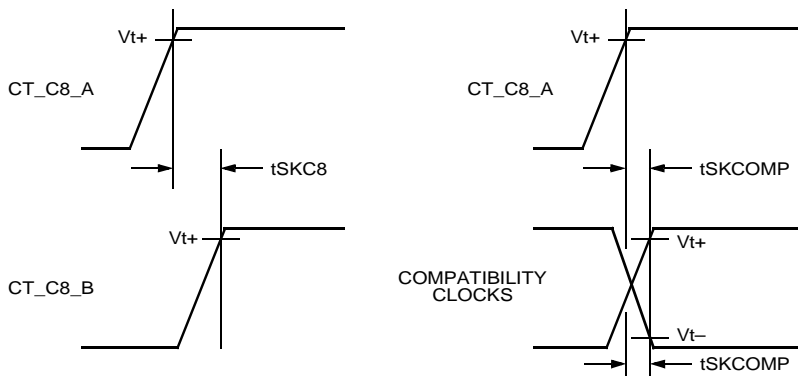

5-6122F

Figure 29. Detailed Clock Skew Timing Diagram

13.7 ac Electrical Characteristics

13.7.1 Skew Timing, H-Bus

Table 109. Skew Timing, H-Bus

Symbol	Parameter	Min	Typical	Max	Unit
tSKC8	Maximum Skew Between CT_C8_A and CT_C8_B* †‡§	—	—	±10, ±Φ	ns
TSKCOMP	Maximum Skew Between CT_C8_A and any Compatibility Clock*	—	—	±5	ns
—	Maximum Skew Between CT_C8_A and L_SCx Clock*	—	—	±2	ns

* Test load—50 pF.

† Assumes A and B masters in adjacent slots.

‡ When static skew is 10 ns and in the same clock cycle, each clock performs a 10 ns phase correction in opposite directions, a maximum skew of 30 ns will occur during that clock cycle.

§ Meeting the skew requirements in Table 109 and the requirements of Section 15.5 H-Bus Timing on page 129 could require the PLLs generating CT_C8 to have different time constants when acting as primary and secondary clock masters.

13 Electrical Characteristics (continued)

13.7 ac Electrical Characteristics (continued)

13.7.1 Skew Timing, H-Bus (continued)

Table 110. L_SC[3:0] and Frame Group Rise and Fall Time

Parameter	Min	Typ	Max	Unit*
L_SCx Rise Time	—	—	5	ns
L_SCx Fall Time	—	—	4	ns
Frame Group Rise Time	—	—	3	ns
Frame Group Fall Time	—	—	3	ns

* Worst-case loading of 50 pF on all outputs.

13.8 Hot Swap

The T8110L has features which assist in H.110 hot swap applications. All H.110 bus signals are put in high impedance (3-state and/or input) during the early power phase of board insertion/removal. The ECTF H.110 specification requires that all CT data lines and CT_NETREF clocks have 0.7 V applied through 18 kΩ resistors before plugging into and releasing from the H.110 bus. A feature on the T8110L incorporates all 34 18 kΩ precharge resistors internally (32 for the CT data signals, 2 for NETREFs). These resistors accept 0.7 V directly through the VPRE-CHARGE input. The ECTF H.110 specification requires that the T8110L must be powered from early power in hot swap applications. The circuit that generates the 0.7 V precharge voltage must also be powered from early power. Refer to ECTF H.110 and *PICMG CompactPCI[®] Hot Swap* specifications for hot swap requirements.

13.8.1 LPUE (Local Pull-Up Enable)

LPUE is used as an assist in *CompactPCI* specifically for hot swap; see Section 2.3.2 on page 20. During live board insertion/removal, the only devices which should be on early power are the power controller and interface parts (PCI interface attached to J1, H.110 interface attached to J4). Without the LPUE, any device connected to the T8110L would get current flow from the early power through the pull-up resistors. When late power parts power up, they already have current flowing through the I/O and these devices could possibly latch up. The current flow is eliminated by LPUE disabling the pull-up resistors. LPUE is typically controlled by the power controller. The power controller will pull LPUE low during board insertion/removal and will release LPUE high so that the pull ups are re-enabled with late power turning on. Signals that have pull-ups disabled by LPUE are GP[7:0], FG[7:0], D[15:0], LD[31:0], LREF[7:0], PRI_REF_IN, NR1_DIV_IN, and NR2_DIV_IN.

13.9 Decoupling

Decoupling the T8110L VDDs with 0.1 μF capacitors is recommended. 1000 pF or 0.01 μF capacitors may be used in addition to the 0.1 μF capacitors to provide additional decoupling.

13 Electrical Characteristics (continued)

13.10 APLL V_{DD} Filter

Separate V_{DD}s are provided for APLL1 and APLL2 for filtering purposes. V_{DD} filtering will provide stability in the APLL, primarily the VCOs. An R/C low pass filter should be applied to the PLL V_{DD}s, see Figure 30. Depending on the quality of V_{DD} and board layout characteristics, the R/C values should be selected to filter out unwanted frequencies above a targeted frequency. For example, a 25 Ω resistor and 10 μF capacitor will have a cut-off frequency of 636 Hz. Characterize the quality of your V_{DD} and select component values accordingly. 25 Ω is the maximum recommended resistor value. At high frequencies the ESR of a bulk cap becomes a problem (no longer effectively low passes) so a high-frequency cap of 0.1 μF or so is required to compensate for some of the higher clocks and various harmonics. This needs to be placed as close to the T8110L device as possible to minimize the radiational pick-up in the remaining trace length. APLL1 and APLL2 each draw approximately 7 mA at 3.3 V. Hot swap applications can use late power to ensure the capacitance and in-rush current do not violate the PICMG Hot Swap specification.

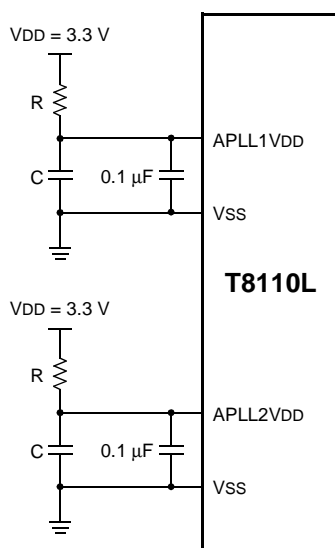

0995(F)

Figure 30. APLL V_{DD} Filtering

13 Electrical Characteristics (continued)

13.11 PC Board PBGA Considerations

The T8110L is a 272-ball plastic ball grid array package. The 16 centrally located thermal balls should be connected to board ground. While there are no special printed-circuit board requirements for the T8110L, there are specification requirements for PC board layout that must be adhered to. For instance, per the ECTF H.110 specification, all CT bus data signals must not exceed 4 inches in length from connector to I/O cell and all CT bus clock signals must not exceed 2 inches in length from connector to I/O cell. We advise the customer to become familiar with applicable specifications for any PC board requirements.

13.12 Unused Pins

Multiple pins may share a common resistor. Signals with pull-up/down resistors may be left unconnected if unused. Unused 8 mA 3-state signals may be left unconnected. If XTAL1_IN and/or XTAL2_IN are being driven from an oscillator, then XTAL1_OUT and/or XTAL2_OUT must be left unconnected. If XTAL2 is not used, XTAL2_IN should be pulled-up or tied directly to V_{DD} and XTAL2_OUT should be left unconnected. If VPRECHARGE is unused, this signal may be left unconnected. All signals listed as **no connect** (D16, D20, E17, and G17) in Table 8 must be left unconnected.

13.13 External Pull-Up Pins

The EPU pins must be tied to an external pull-up resistor. Multiple pins may share a common resistor. It is recommended that all EPU pins be tied to a common 20 kΩ pull-up resistor.

13.14 T8110L Evaluation Kits

There is no T8110L-specific evaluation kit. If an evaluation kit is required, please purchase a T8110 PCI evaluation kit, as the evaluation board allows the T8110 to be configured to be functionally identical to the T8110L. Each kit contains an evaluation board, software, and documentation. The evaluation board is a full-length PCI board and it includes the T8110 chip, a PCI-to-local bus bridge, a dual T1/E1 line interface, a dual codec, and a dual SLIC. The software includes full source code, including rights to reuse. The documentation CD includes evaluation board schematics (ORCAD and .pdf formats), evaluation board bill of material (BOM), and advisories. Please refer to the website http://www.agere.com/enterprise_metro_access/t8110_interconnect.html for additional information.

13.15 T8110L Ordering Information

Table 111. T8110L Ordering Information

Device Part Number	Package	Comcode
T-8110L---BAL-DB	272-Ball PBGA	700052229

13 Package Outline (continued)

13.15 Pin and Pad Assignments (continued)

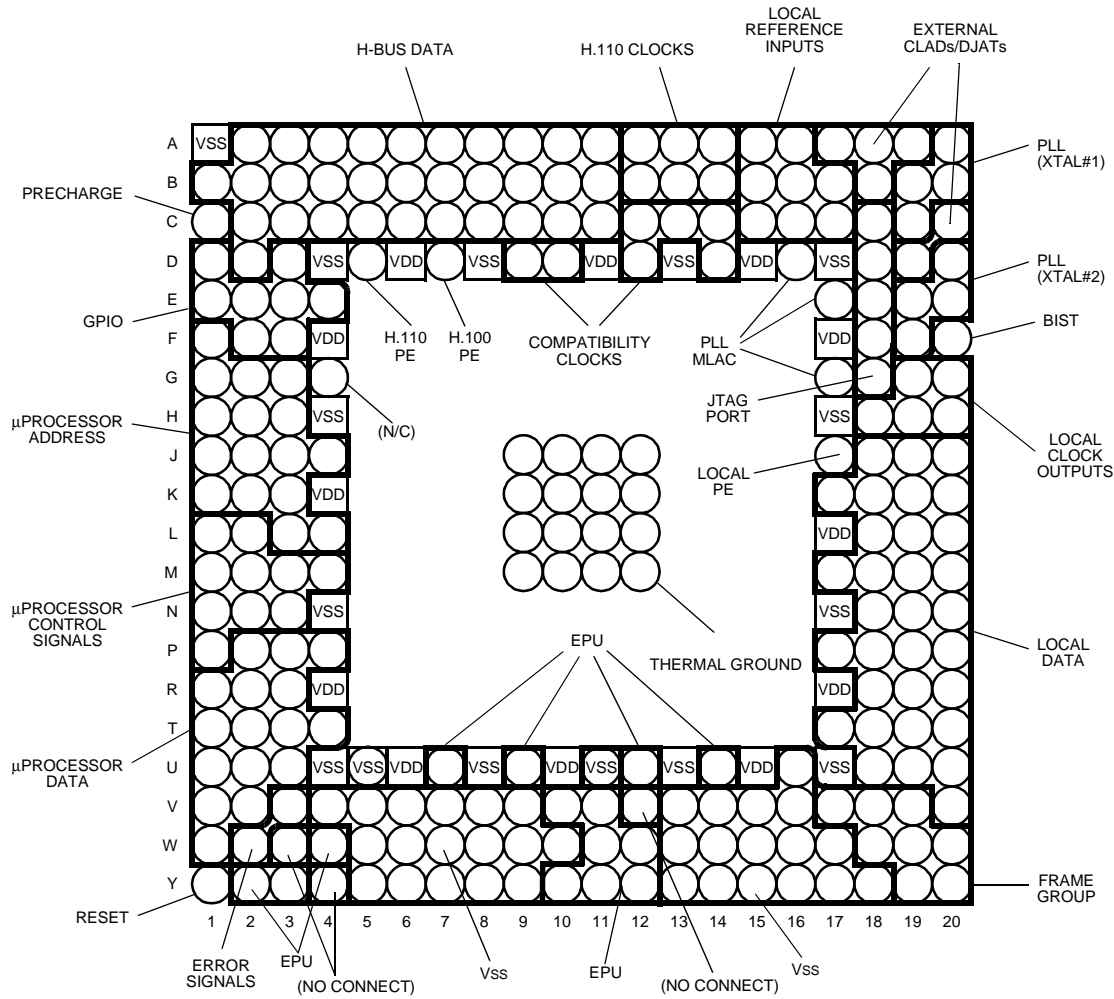

5-8906F(b).

Figure 31. T8110L Pins by Functional Group

13 Package Outline (continued)

13.15 Pin and Pad Assignments (continued)

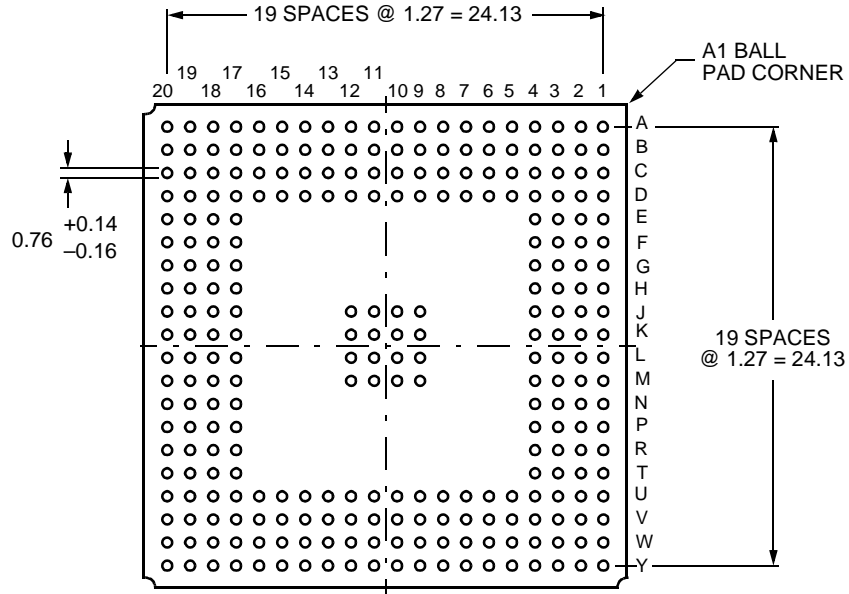

BOTTOM VIEW

5-4406

13 Package Outline (continued)

13.15 Pin and Pad Assignments (continued)

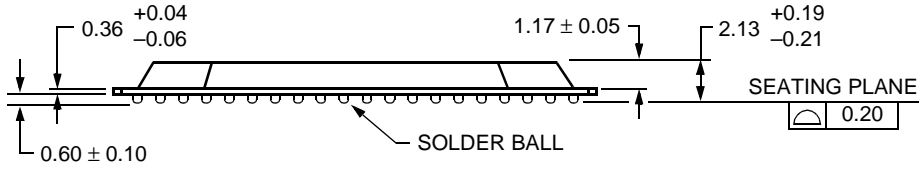

SIDE VIEW

5-4406

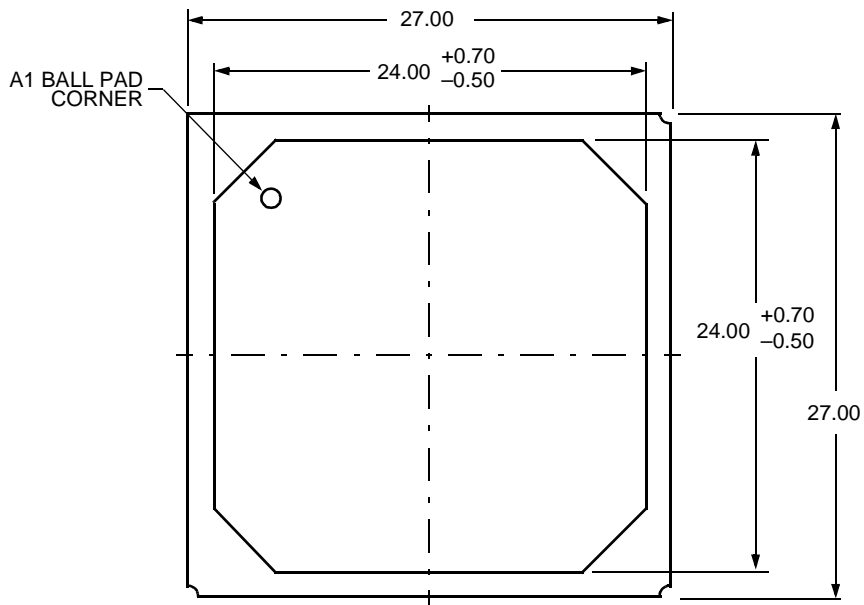

TOP VIEW

5-4406

14 JTAG/Boundary Scan

14.1 The Principle of Boundary-Scan Architecture

Each primary input signal and primary output signal is supplemented with a multipurpose memory element called a boundary-scan cell. Cells on device primary inputs are referred to as input cells and cells on primary outputs are referred to as output cells. Input and output is relative to the core logic of the device.

At any time, only one register can be connected from TDI to TDO. For example, instruction register (IR), bypass, boundary-scan, ident, or even some appropriate register internal to the core logic (see Figure 32). The selected register is identified by the decoded output of the instruction register. Certain instructions are mandatory, such as EXTEST (boundary-scan register selected), whereas others are optional, such as the IDCODE instruction (Ident register selected).

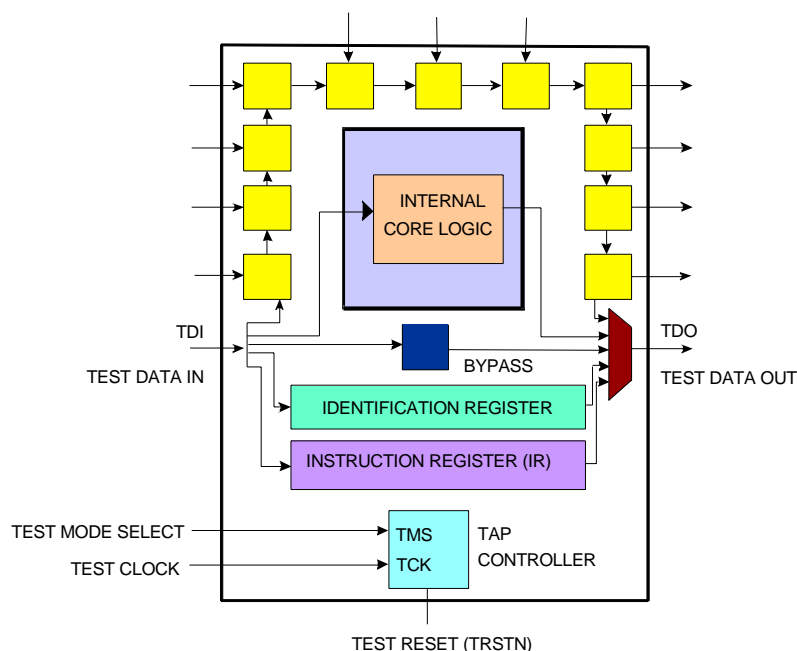

Figure 32. IEEE® 1149.1 Boundary-Scan Architecture

Figure 32 shows the following elements:

- A set of four dedicated test pins, test data in (TDI), test mode select (TMS), test clock (TCK), test data out (TDO), and one optional test pin test reset (TRSTN). These pins are collectively referred to as the test access port (TAP).
- A boundary-scan cell on each device's primary input and primary output pin, connected internally to form a serial boundary-scan register (boundary scan).
- A finite-state machine TAP controller with inputs TCK and TMS.
- An n-bit ($n = 3$) instruction register (IR), holding the current instruction.
- A 1-bit bypass register (BYPASS).
- An optional 32-bit identification register (ident) capable of being loaded with a permanent device identification code.

14 JTAG/Boundary Scan (continued)**14.1.1 Instruction Register**

The instruction register is 3 bits long and the capture value is 001.

Table 112. Instruction Register

Instruction	Binary Code	Description
EXTEST	000	Places the boundary-scan register in EXTEST mode.
SAMPLE	001	Places the boundary-scan register in sample mode.
IDCODE	101	Identification code.
BYPASS	110, 111	Places the bypass register in the scan chain.
HIGH Z	010	Places all outputs and I/Os in 3-state mode.

14.2 Boundary-Scan Register

The T8110L boundary scan register is identical to that of the T8110 in the condition that the T8110's VIO/uP_SELECT pin is tied to ground. The only difference is that for the T8110L, this pin (U5) is internally tied to ground. Please refer to the T8110 datasheet for the bit-to-pin assignment.

Appendix A. Constant and Minimum Delay Connections

A.1 Connection Definitions

A forward connection is defined as one in which the output **to** time slot has a greater value than the input **from** time slot, or, put another way, the delta between them is positive.

A reverse connection is defined as one in which the output **to** time slot has a lesser value than the input **from** time slot, and the delta between them is negative.

For example, going from TS(1) to TS(38) is a forward connection, and the $TS\Delta$ is +37, but going from TS(38) to TS(1) is a reverse connection, with a $TS\Delta$ of -37:

$$\text{where } TS\Delta = TS(\mathbf{to}) - TS(\mathbf{from}).$$

Similarly, a delta can be introduced for streams which will have a bearing in certain exceptions (discussed later):

$$STR\Delta = STR(\mathbf{to}) - STR(\mathbf{from}).$$

There is only one combination which forms a $TS\Delta$ of +127 or -127:

$$\begin{aligned} TS\Delta &= TS(127) - TS(0) = +127, \text{ and} \\ TS\Delta &= TS(0) - TS(127) = -127, \end{aligned}$$

but there are two combinations which form $TS\Delta$ s of +126 or -126:

$$\begin{aligned} TS\Delta &= TS(127) - TS(1) = TS(126) - TS(0) = +126, \text{ and} \\ TS\Delta &= TS(1) - TS(127) = TS(0) - TS(126) = -126, \end{aligned}$$

there are three combinations which yield +125 or -125, and so on.

The user can utilize the $TS\Delta$ to control the latency of the resulting connection. In some cases, the latency must be minimized. In other cases, such as a block of connections which must maintain some relative integrity while crossing a frame boundary, the required latency of some of the connections may exceed a one frame (>128 time slots) to maintain the integrity of this virtual frame.

The device uses a control bit at each connection memory location, VFC, for controlling latency, allowing each connection to select one of two alternating data buffers.

A.2 Delay Type Definitions

Constant Delay—This is a well-defined, predictable, and linear region of latency in which the **to** time slot is at least 128 time slots after the **from** time slot, but no more than 256 time slots after the **from** time slot.

Mathematically, constant delay latency is described as follows*, with L denoting latency, and VFC set to the value indicated:

$$\text{Forward connections, VFC = 1: } L = 128 + TS\Delta \quad (0 \leq TS\Delta \leq 127)$$

$$\text{Reverse connections, VFC = 0: } L = 256 + TS\Delta \quad (-127 \leq TS\Delta \leq -1)$$

Example: Switching from TS(37) to TS(1) as a constant delay, the delta is -36, so FME is set to 0 and the resulting latency is $256 - 36 = 220$ time slots. Thus, the connection will be made from TS(37) of frame(n) to TS(1) of frame(n + 2).

Simple summary: Use constant delay for latencies of 128 to 256 time slots,
set VFC = 1 for forward connections,
set VFC = 0 for reverse connections.

* Since $TS\Delta = TS(\mathbf{to}) - TS(\mathbf{from})$, the user can modify the equations to solve for either $TS(\mathbf{to})$ or $TS(\mathbf{from})$.

Appendix A. Constant and Minimum Delay Connections (continued)

A.2 Delay Type Definitions (continued)

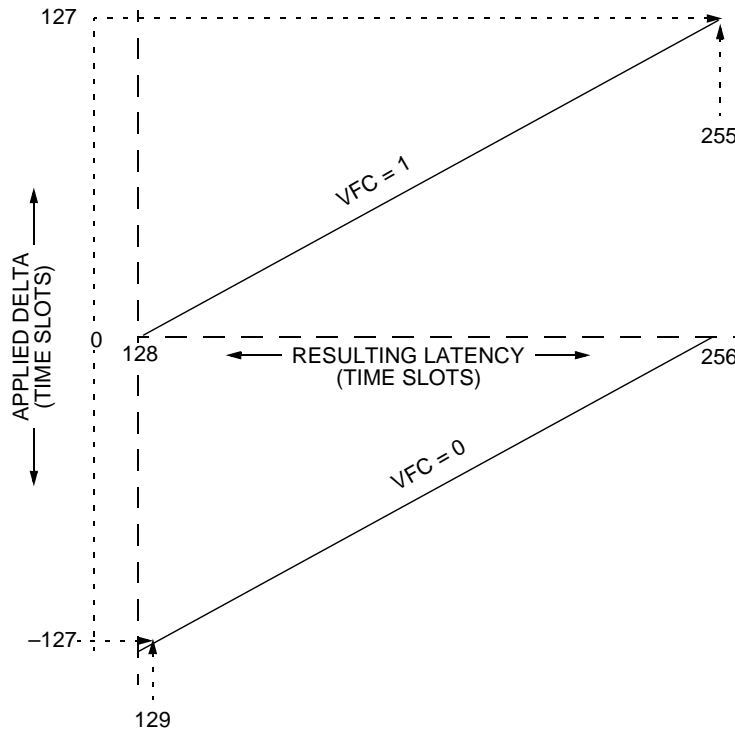

Figure 33. Constant Delay Connection Latency

Minimum Delay—This is the most common type of switching, but has a shorter range than constant delay, and the user must be aware of exceptions caused by interactions between the device's internal pipeline and the dual buffering. The **to** time slot is at least 3 time slots after the **from** time slot, but no more than 128 time slots after the **from** time slot. Exceptions exist at $TS\Delta$ s of +1, +2, -126, and -127.

Forward connections, $VFC = 0$: $L = TS\Delta$ ($3 \leq TS\Delta \leq 127$).

Reverse connections, $VFC = 1$: $L = 128 + TS\Delta$ ($-125 \leq TS\Delta \leq 0$).

Example: Using the same switching from the example above, $TS(37)$ to $TS(1)$, the delta is -36, so VFC is set to 1 to effect the minimum delay (setting to 0 effects constant delay), and the resulting latency is $128 - 36 = 92$ time slots. The relative positions of the end time slots are the same in both minimum and constant delay, i.e., they both switch to $TS(1)$, but the actual data is delayed by an additional frame in the constant delay case.

Simple summary: Use minimum delay for latencies of 3 to 128 time slots,
set $VFC = 0$ for forward connections,
set $VFC = 1$ for reverse connections.

Exceptions to Minimum Delay—Up until this point in the discussion, the $STR\Delta$ s have not been discussed because the **to** and **from** streams have been irrelevant in the switching process.

Note: The one universally disallowed connection on the device is a $TS\Delta$ of 0 and a $STR\Delta$ of 0. This is, of course, a stream + time-slot switching to itself!

Rather than try to list the exceptions mathematically, a table is provided. The latencies in these cases may exceed two frames due to the interaction of the intrinsic pipeline delays with the double buffering.

Appendix A. Constant and Minimum Delay Connections (continued)

A.2 Delay Type Definitions (continued)

Table 113. Special Cases (Exceptions)

VFC Value	TS_{Δ}	Latency for $STR_{\Delta} < 0$	Latency for $STR_{\Delta} \geq 0$
0	+1	257	257
0	+2	258	2
1	-126	258	2
1	-127	257	257

Graphically, the minimum delay latency equations are illustrated below. The exceptions to the minimum delay have been included in the diagram, connected to the main function by dashed lines.

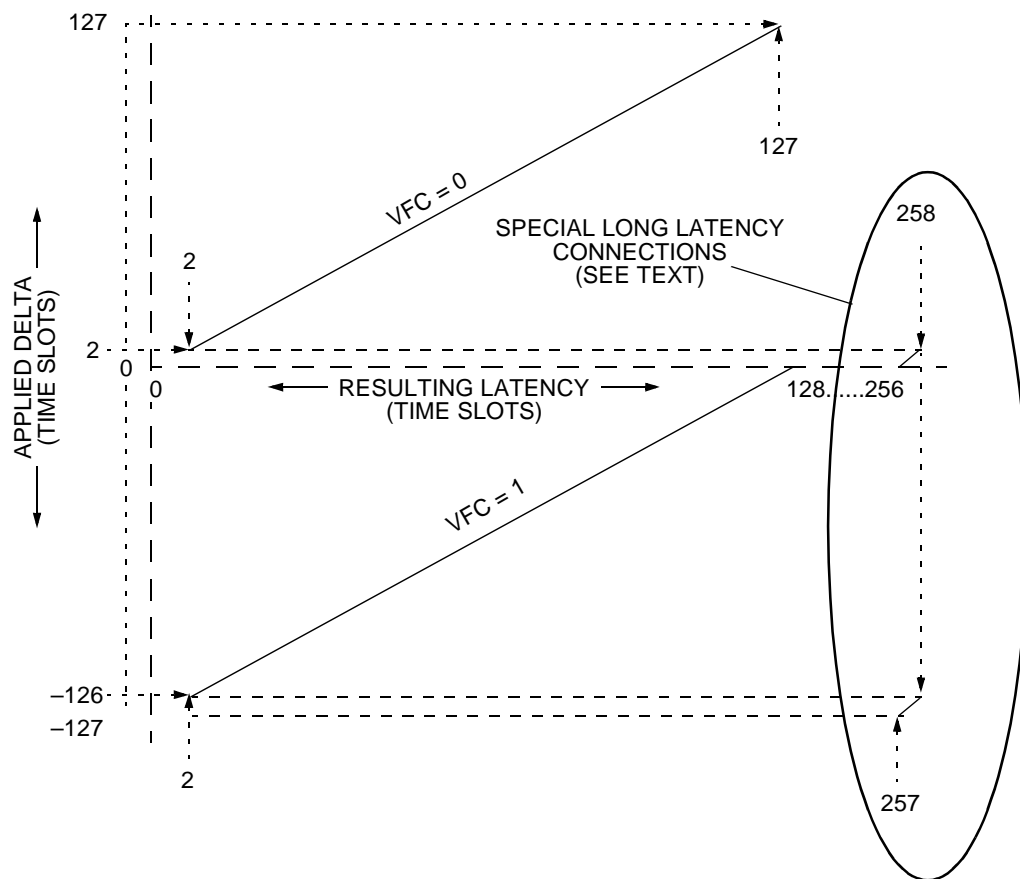

5-6224

Figure 34. Minimum Delay Connection Latency

Lower Stream Rates—The discussion has centered on 128 time-slot frames which correspond to 8.192 Mb/s data rates. How does one make similar predictions for lower stream rates?

For 4.096 Mb/s, multiply the **to** and **from** time-slot values by two, i.e., time slot 0 at 4.096 Mb/s corresponds to time slot 0 at 8.192 Mb/s, and time slot 63 at 4.096 Mb/s corresponds to time slot 126 at 8.192 Mb/s. Similarly, multiply values by four to convert 2.048 Mb/s values. The latency equations can then be applied directly.

Appendix B. Register Bit Field Mnemonic Summary

Key to using the table below:

- Five character alphanumeric designation
- Character 4 indicates the general register type as follows:
 - Divide = load value for divider
 - Enable = bit or bits to enable a function
 - Load = load value, typically for counter
 - Output = output only
 - Select = bit or bits select multiple functions
- Character 5 indicates the size as follows:
 - B = bit
 - N = nibble
 - P = partial register (2, 3, 5, 6, or 7 bits)
 - R = register
- Position column identifies the bit position in the register:
 - 0, 1, 2, 3, 4, 5, 6, 7 for bits
 - L for lower nibble
 - U for upper nibble
 - n-m for bit positions in a partial register

Appendix B. Register Bit Field Mnemonic Summary (continued)

Table 114. Mnemonic Summary, Sorted by Name

Mnemonic	Description	Type	Register	Bit Position
ABOEN	A and B clocks output	Enable	0x00220	U
ACRSN	A clocks rate	Select	0x00223	L
AIOEB	All I/O (master)	Enable	0x00103	7
BCRSN	B clocks rate	Select	0x00223	U
C2FEB	C2 fallback trigger	Enable	0x0010A	5
C2LOB	C2 latched error	Output	0x00122	5
C2TOB	C2 transient error	Output	0x00120	5
C2WEB	C2 watchdog	Enable	0x0010E	5
C4FEB	/C4 fallback trigger	Enable	0x0010A	4
C4LOB	C4 latched error	Output	0x00122	4
C4TOB	C4 transient error	Output	0x00120	4
C4WEB	/C4 watchdog	Enable	0x0010E	4
CAFEB	C8A fallback trigger	Enable	0x0010A	0
CALOB	C8A latched error	Output	0x00122	0
CATOB	C8A transient error	Output	0x00120	0
CAWEB	C8A watchdog	Enable	0x0010E	0
CAWSN	C8A watchdog	Select	0x0010C	L
CBFEB	C8B fallback trigger	Enable	0x0010A	1
CBLOB	C8B latched error	Output	0x00122	1
CBTOB	C8B transient error	Output	0x00120	1
CBWEB	C8B watchdog	Enable	0x0010E	1
CBWSN	C8B watchdog	Select	0x0010C	U
CCOEN	C clocks output	Enable	0x00220	L
CCSEN	C clocks separate	Enable	0x00224	L
CFBOB	Fallback status	Output	0x00127	6
CFHLN	Diag sync-to-frame high	Load	0x0014B	L
CFLLR	Diag sync-to-frame low	Load	0x0014A	—
CFPOB	CLEAR_FALLBACK pending	Output	0x00124	1
CFSEN	Diag sync-to-frame EN	Enable	0x0014B	U
CFSOB	Failsafe status	Output	0x00127	7
CKMDR	Clock main	Divide	0x00201	—
CKMSR	Clock main	Select	0x00200	—
CKRDR	Clock resource	Divide	0x00205	—
CMFEB	/C16– fallback trigger	Enable	0x0010A	3
CMLOB	/C16– latched error	Output	0x00122	3
CMTOB	/C16– transient error	Output	0x00120	3
CMWEB	/C16– watchdog	Enable	0x0010E	3
CPFEB	/C16+ fallback trigger	Enable	0x0010A	2
CPLOB	/C16+ latched error	Output	0x00122	2
CPTOB	/C16+ transient error	Output	0x00120	2
CPWEB	/C16+ watchdog	Enable	0x0010E	2
CSASR	Clock set access	Select	0x00106	—
D1FEB	DPLL1 sync trigger	Enable	0x0010B	5
D1ISR	DPLL1 input	Select	0x0020A	—

Appendix B. Register Bit Field Mnemonic Summary (continued)**Table 114. Mnemonic Summary, Sorted by Name** (continued)

Mnemonic	Description	Type	Register	Bit Position
D1LOB	DPLL1 sync latched error	Output	0x00123	5
D1RSR	DPLL1 rate	Select	0x0020B	—
D1TOB	DPLL1 sync transient error	Output	0x00121	5
D1WEB	DPLL1 sync watchdog	Enable	0x0010F	5
D2FEB	DPLL2 sync trigger	Enable	0x0010B	6
D2ISR	DPLL2 input	Select	0x0020E	—
D2LOP	DPLL2 lock status	Output	0x00125	3:2
D2RSR	DPLL2 rate	Select	0x0020F	—
D2TOB	DPLL2 sync transient error	Output	0x00121	6
D2WEB	DPLL2 sync watchdog	Enable	0x0010F	6
DMMS	Data memory mode	Select	0x00105	6:0
F0DSB	FGIO 0 R/W direction	Select	0x00482	0
F0IOB	FGIO 0 data	Load	0x00480	0
F0ISB	Frame 0 pulse inversion	Enable	0x00402	7
F0LLR	Frame 0 lower start time	Load	0x00400	—
F0MEB	FGIO 0 read mask	Enable	0x00481	0
F0RSR	Frame 0 pulse width rate	Select	0x00403	—
F0ULR	Frame 0 upper start time	Load	0x00401	—
F0WSP	Frame 0 pulse width	Select	0x00402	6:0
F1DSB	FGIO 1 R/W direction	Select	0x00482	1
F1IOB	FGIO 1 data	Load	0x00480	1
F1ISB	Frame 1 pulse inversion	Enable	0x00412	7
F1LLR	Frame 1 lower start time	Load	0x00410	—
F1MEB	FGIO 1 read mask	Enable	0x00481	1
F1RSR	Frame 1 pulse width rate	Select	0x00413	—
F1ULR	Frame 1 upper start time	Load	0x00411	—
F1WSP	Frame 1 pulse width	Select	0x00412	6:0
F2DSB	FGIO 2 R/W direction	Select	0x00482	2
F2IOB	FGIO 2 data	Load	0x00480	2
F2ISB	Frame 2 pulse inversion	Enable	0x00422	7
F2LLR	Frame 2 lower start time	Load	0x00420	—
F2MEB	FGIO 2 read mask	Enable	0x00481	2
F2RSR	Frame 2 pulse width rate	Select	0x00423	—
F2ULR	Frame 2 upper start time	Load	0x00421	—
F2WSP	Frame 2 pulse width	Select	0x00422	6:0
F3DSB	FGIO 3 R/W direction	Select	0x00482	3
F3IOB	FGIO 3 data	Load	0x00480	3
F3ISB	Frame 3 pulse inversion	Enable	0x00432	7
F3LLR	Frame 3 lower start time	Load	0x00430	—
F3MEB	FGIO 3 read mask	Enable	0x00481	3
F3RSR	Frame 3 pulse width rate	Select	0x00433	—
F3ULR	Frame 3 upper start time	Load	0x00431	—
F3WSP	Frame 3 pulse width	Select	0x00432	6:0

Appendix B. Register Bit Field Mnemonic Summary (continued)

Table 114. Mnemonic Summary, Sorted by Name (continued)

Mnemonic	Description	Type	Register	Bit Position
F4DSB	FGIO 4 R/W direction	Select	0x00482	4
F4IOB	FGIO 4 data	Load	0x00480	4
F4ISB	Frame 4 pulse inversion	Enable	0x00442	7
F4LLR	Frame 4 lower start time	Load	0x00440	—
F4MEB	FGIO 4 read mask	Enable	0x00481	4
F4RSR	Frame 4 pulse width rate	Select	0x00443	—
F4ULR	Frame 4 upper start time	Load	0x00441	—
F4WSP	Frame 4 pulse width	Select	0x00442	6:0
F5DSB	FGIO 5 R/W direction	Select	0x00482	5
F5IOB	FGIO 5 data	Load	0x00480	5
F5ISB	Frame 5 pulse inversion	Enable	0x00452	7
F5LLR	Frame 5 lower start time	Load	0x00450	—
F5MEB	FGIO 5 read mask	Enable	0x00481	5
F5RSR	Frame 5 pulse width rate	Select	0x00453	—
F5ULR	Frame 5 upper start time	Load	0x00451	—
F5WSP	Frame 5 pulse width	Select	0x00452	6:0
F6DSB	FGIO 6 R/W direction	Select	0x00482	6
F6IOB	FGIO 6 data	Load	0x00480	6
F6ISB	Frame 6 pulse inversion	Enable	0x00462	7
F6LLR	Frame 6 lower start time	Load	0x00460	—
F6MEB	FGIO 6 read mask	Enable	0x00481	6
F6RSR	Frame 6 pulse width rate	Select	0x00463	—
F6ULR	Frame 6 upper start time	Load	0x00461	—
F6WSP	Frame 6 pulse width	Select	0x00462	6:0
F7DSB	FGIO 7 R/W direction	Select	0x00482	7
F7IOB	FGIO 7 data	Load	0x00480	7
F7ISB	Frame 7 pulse inversion	Enable	0x00472	7
F7LLR	Frame 7 lower start time	Load	0x00470	—
F7MEB	FGIO 7 read mask	Enable	0x00481	7
F7MSR	Frame 7 mode	Select	0x00476	—
F7RSR	Frame 7 pulse width rate	Select	0x00473	—
F7SSP	FG7 timer pulse shape	Select	0x00477	—
F7ULR	Frame 7 upper start time	Load	0x00471	—
F7WSN	FG7 timer pulse width	Select	0x00477	L
F7WSP	Frame 7 pulse width	Select	0x00472	6:0
FAFEB	/FRAMEA fallback trigger	Enable	0x0010B	0
FALOB	/FRAMEA latched error	Output	0x00123	0
FATOB	/FRAMEA transient error	Output	0x00121	0
FAWEB	/FRAMEA watchdog	Enable	0x0010F	0
FB1SB	APLL1 feedback reset	Select	0x00146	1
FB2SB	APLL2 feedback reset	Select	0x00146	2
FBCSR	Fallback control	Select	0x00108	—
FBFEB	/FRAMEB fallback trigger	Enable	0x0010B	1

Appendix B. Register Bit Field Mnemonic Summary (continued)

Table 114. Mnemonic Summary, Sorted by Name (continued)

Mnemonic	Description	Type	Register	Bit Position
FBFOB	Fallback enable status	Output	0x00124	7
FBLOB	/FRAMEB latched error	Output	0x00123	1
FBSOP	Fallback states	Output	0x00124	6:4
FBTOB	/FRAMEB transient error	Output	0x00121	1
FBWEB	/FRAMEB watchdog	Enable	0x0010F	1
FCFEB	/FR_COMP fallback trigger	Enable	0x0010B	2
FCISB	FG7 timer invert output	Select	0x00477	7
FCLLR	Frame group 7 lower count	Load	0x00474	—
FCLOB	/FR_COMP latched error	Output	0x00123	2
FCTOB	/FR_COMP transient error	Output	0x00121	2
FCULR	Frame group 7 upper count	Load	0x00475	—
FCWEB	/FR_COMP watchdog	Enable	0x0010F	2
FFPOB	FORCE_FALLBACK pending	Output	0x00124	0
FGREB	Frame group	Enable	0x00103	5
FPASR	Frame phase alignment	Select	0x00107	—
FRMSB	Diag /FR_COMP input	Select	0x00145	4
FRSEN	/FR_COMP separate	Enable	0x00224	U
FRWSR	/FR_COMP width	Select	0x00222	—
FSCSR	Failsafe return command	Select	0x00114	—
FSEER	Failsafe enable	Enable	0x00115	—
FSLOB	Failsafe latched error	Output	0x00123	7
FSMSN	Fallback secondary mode	Select	0x00109	L
FSSSR	Failsafe sensitivity	Select	0x00116	—
FSTOB	Failsafe transient error	Output	0x00121	7
FSWEB	Failsafe watchdog	Enable	0x0010F	7
FT0EB	FG0 testpoint	Enable	0x00140	0
FT1EB	FG1 testpoint	Enable	0x00140	1
FT2EB	FG2 testpoint	Enable	0x00140	2
FT3EB	FG3 testpoint	Enable	0x00140	3
FT4EB	FG4 testpoint	Enable	0x00140	4
FT5EB	FG5 testpoint	Enable	0x00140	5
FT6EB	FG6 testpoint	Enable	0x00140	6
FT7EB	FG7 testpoint	Enable	0x00140	7
FTPSR	FG testpoint MUX	Select	0x00141	—
FTRSN	Fallback type	Select	0x00109	U
G0DSB	GPIO 0 R/W direction	Select	0x00502	0
G0IOB	GPIO 0 data	Load	0x00500	0
G0MEB	GPIO 0 read mask	Enable	0x00501	0
G0OEB	GPIO 0 override	Enable	0x00503	0
G1DSB	GPIO 1 R/W direction	Select	0x00502	1
G1IOB	GPIO 1 data	Load	0x00500	1
G1MEB	GPIO 1 read mask	Enable	0x00501	1
G1OEB	GPIO 0 override	Enable	0x00503	1

Appendix B. Register Bit Field Mnemonic Summary (continued)

Table 114. Mnemonic Summary, Sorted by Name (continued)

Mnemonic	Description	Type	Register	Bit Position
G2DSB	GPIO 2 R/W direction	Select	0x00502	2
G2IOB	GPIO 2 data	Load	0x00500	2
G2MEB	GPIO 2 read mask	Enable	0x00501	2
G3DSB	GPIO 3 R/W direction	Select	0x00502	3
G3IOB	GPIO 3 data	Load	0x00500	3
G3MEB	GPIO 3 read mask	Enable	0x00501	3
G4DSB	GPIO 4 R/W direction	Select	0x00502	4
G4IOB	GPIO 4 data	Load	0x00500	4
G4MEB	GPIO 4 read mask	Enable	0x00501	4
G5DSB	GPIO 5 R/W direction	Select	0x00502	5
G5IOB	GPIO 5 data	Load	0x00500	5
G5MEB	GPIO 5 read mask	Enable	0x00501	5
G6DSB	GPIO 6 R/W direction	Select	0x00502	6
G6IOB	GPIO 6 data	Load	0x00500	6
G6MEB	GPIO 6 read mask	Enable	0x00501	6
G7DSB	GPIO 7 R/W direction	Select	0x00502	7
G7IOB	GPIO 7 data	Load	0x00500	7
G7MEB	GPIO 7 read mask	Enable	0x00501	7
GOPOB	Go clocks pending	Output	0x00124	2
GPIEB	General purpose I/O	Enable	0x00103	4
GSREB	Global subrate	Enable	0x00105	7
GT0EB	GP0 testpoint	Enable	0x00142	0
GT1EB	GP1 testpoint	Enable	0x00142	1
GT2EB	GP2 testpoint	Enable	0x00142	2
GT3EB	GP3 testpoint	Enable	0x00142	3
GT4EB	GP4 testpoint	Enable	0x00142	4
GT5EB	GP5 testpoint	Enable	0x00142	5
GT6EB	GP6 testpoint	Enable	0x00142	6
GT7EB	GP7 testpoint	Enable	0x00142	7
GTPSR	GP testpoint MUX	Select	0x00143	—
HARSN	H1x0 group A rate	Select	0x00300	L
HBRSN	H1x0 group B rate	Select	0x00300	U
HCKEB	H1x0 clocks	Enable	0x00103	3
HCRSN	H1x0 group C rate	Select	0x00301	L
HDBEB	H1x0 data bus	Enable	0x00103	2
HDRSN	H1x0 group D rate	Select	0x00301	U
HERSN	H1x0 group E rate	Select	0x00302	L
HFRSN	H1x0 group F rate	Select	0x00302	U
HGRSN	H1x0 group G rate	Select	0x00303	L
HHRSN	H1x0 group H rate	Select	0x00303	U
HRBEB	Hard reset of back end	Enable	0x00101	1
IASLR	Diag, SYSERR assertion	Load	0x00149	—
ICDSP	Diag, internal control mode	Select	0x00148	7:6

Appendix B. Register Bit Field Mnemonic Summary (continued)**Table 114. Mnemonic Summary, Sorted by Name** (continued)

Mnemonic	Description	Type	Register	Bit Position
ICKLP	Diag, internal control CLKERR	Load	0x00148	5:4
ICMSB	Invert clock main	Select	0x00204	4
IDHOR	Device ID high	Output	0x0012B	—
IDLOR	Device ID low	Output	0x0012A	—
IXELP	Diag, internal control EXTERR	Load	0x00148	1:0
IF0SB	Invert interrupt FGIO 0	Select	0x00603	0
IF1SB	Invert interrupt FGIO 1	Select	0x00603	1
IF2SB	Invert interrupt FGIO 2	Select	0x00603	2
IF3SB	Invert interrupt FGIO 3	Select	0x00603	3
IF4SB	Invert interrupt FGIO 4	Select	0x00603	4
IF5SB	Invert interrupt FGIO 5	Select	0x00603	5
IF6SB	Invert interrupt FGIO 6	Select	0x00603	6
IF7SB	Invert interrupt FGIO 7	Select	0x00603	7
IG0SB	Invert interrupt GPIO 0	Select	0x00607	0
IG1SB	Invert interrupt GPIO 1	Select	0x00607	1
IG2SB	Invert interrupt GPIO 2	Select	0x00607	2
IG3SB	Invert interrupt GPIO 3	Select	0x00607	3
IG4SB	Invert interrupt GPIO 4	Select	0x00607	4
IG5SB	Invert interrupt GPIO 5	Select	0x00607	5
IG6SB	Invert interrupt GPIO 6	Select	0x00607	6
IG7SB	Invert interrupt GPIO 7	Select	0x00607	7
IR0SB	Invert local reference 0	Select	0x0020C	0
IR1SB	Invert local reference 1	Select	0x0020C	1
IR2SB	Invert local reference 2	Select	0x0020C	2
IR3SB	Invert local reference 3	Select	0x0020C	3
IR4SB	Invert local reference 4	Select	0x0020C	4
IR5SB	Invert local reference 5	Select	0x0020C	5
IR6SB	Invert local reference 6	Select	0x0020C	6
IR7SB	Invert local reference 7	Select	0x0020C	7
ISYLP	Diag, internal control SYSERR	Load	0x00148	3:2
JAMSR	Interrupt arbitration mode	Select	0x00610	—
JC0EB	Interrupt from CLKERR 0	Enable	0x0060E	0
JC0OB	Interrupt pending CLKERR 0	Output	0x0060C	0
JC1EB	Interrupt from CLKERR 1	Enable	0x0060E	1
JC1OB	Interrupt pending CLKERR 1	Output	0x0060C	1
JC2EB	Interrupt from CLKERR 2	Enable	0x0060E	2
JC2OB	Interrupt pending CLKERR 2	Output	0x0060C	2
JC3EB	Interrupt from CLKERR 3	Enable	0x0060E	3
JC3OB	Interrupt pending CLKERR 3	Output	0x0060C	3
JC4EB	Interrupt from CLKERR 4	Enable	0x0060E	4
JC4OB	Interrupt pending CLKERR 4	Output	0x0060C	4
JC5EB	Interrupt from CLKERR 5	Enable	0x0060E	5

Appendix B. Register Bit Field Mnemonic Summary (continued)

Table 114. Mnemonic Summary, Sorted by Name (continued)

Mnemonic	Description	Type	Register	Bit Position
JC5OB	Interrupt pending CLKERR 5	Output	0x0060C	5
JC6EB	Interrupt from CLKERR 6	Enable	0x0060E	6
JC6OB	Interrupt pending CLKERR 6	Output	0x0060C	6
JC7EB	Interrupt from CLKERR 7	Enable	0x0060E	7
JC7OB	Interrupt pending CLKERR 7	Output	0x0060C	7
JC8EB	Interrupt from CLKERR 8	Enable	0x0060F	0
JC8OB	Interrupt pending CLKERR 8	Output	0x0060D	0
JC9EB	Interrupt from CLKERR 9	Enable	0x0060F	1
JC9OB	Interrupt pending CLKERR 9	Output	0x0060D	1
JCAEB	Interrupt from CLKERR A	Enable	0x0060F	2
JCAOB	Interrupt pending CLKERR A	Output	0x0060D	2
JCBEB	Interrupt from CLKERR B	Enable	0x0060F	3
JCBOB	Interrupt pending CLKERR B	Output	0x0060D	3
JCCEB	Interrupt from CLKERR C	Enable	0x0060F	4
JCCOB	Interrupt pending CLKERR C	Output	0x0060D	4
JCDEB	Interrupt from CLKERR D	Enable	0x0060F	5
JCDOB	Interrupt pending CLKERR D	Output	0x0060D	5
JCEEB	Interrupt from CLKERR E	Enable	0x0060F	6
JCEOB	Interrupt pending CLKERR E	Output	0x0060D	6
JCFEB	Interrupt from CLKERR F	Enable	0x0060F	7
JCFOB	Interrupt pending CLKERR F	Output	0x0060D	7
JCOSR	Interrupt CLKERR output mode	Select	0x00613	—
JCWSR	Interrupt CLKERR pulse width	Select	0x00617	—
JF0EB	Interrupt from FGIO 0	Enable	0x00601	0
JF0OB	Interrupt pending FGIO 0	Output	0x00600	0
JF1EB	Interrupt from FGIO 1	Enable	0x00601	1
JF1OB	Interrupt pending FGIO 1	Output	0x00600	1
JF2EB	Interrupt from FGIO 2	Enable	0x00601	2
JF2OB	Interrupt pending FGIO 2	Output	0x00600	2
JF3EB	Interrupt from FGIO 3	Enable	0x00601	3
JF3OB	Interrupt pending FGIO 3	Output	0x00600	3
JF4EB	Interrupt from FGIO 4	Enable	0x00601	4
JF4OB	Interrupt pending FGIO 4	Output	0x00600	4
JF5EB	Interrupt from FGIO 5	Enable	0x00601	5
JF5OB	Interrupt pending FGIO 5	Output	0x00600	5
JF6EB	Interrupt from FGIO 6	Enable	0x00601	6
JF6OB	Interrupt pending FGIO 6	Output	0x00600	6
JF7EB	Interrupt from FGIO 7	Enable	0x00601	7
JF7OB	Interrupt pending FGIO 7	Output	0x00600	7
JG0EB	Interrupt from GPIO 0	Enable	0x00605	0
JG0OB	Interrupt pending GPIO 0	Output	0x00604	0
JG1EB	Interrupt from GPIO 1	Enable	0x00605	1
JG1OB	Interrupt pending GPIO 1	Output	0x00604	1
JG2EB	Interrupt from GPIO 2	Enable	0x00605	2

Appendix B. Register Bit Field Mnemonic Summary (continued)**Table 114. Mnemonic Summary, Sorted by Name** (continued)

Mnemonic	Description	Type	Register	Bit Position
JG2OB	Interrupt pending GPIO 2	Output	0x00604	2
JG3EB	Interrupt from GPIO 3	Enable	0x00605	3
JG3OB	Interrupt pending GPIO 3	Output	0x00604	3
JG4EB	Interrupt from GPIO 4	Enable	0x00605	4
JG4OB	Interrupt pending GPIO 4	Output	0x00604	4
JG5EB	Interrupt from GPIO 5	Enable	0x00605	5
JG5OB	Interrupt pending GPIO 5	Output	0x00604	5
JG6EB	Interrupt from GPIO 6	Enable	0x00605	6
JG6OB	Interrupt pending GPIO 6	Output	0x00604	6
JG7EB	Interrupt from GPIO 7	Enable	0x00605	7
JG7OB	Interrupt pending GPIO 7	Output	0x00604	7
JISOR	Interrupt in-service	Output	0x006FC	—
JS0EB	Interrupt from SYSERR 0	Enable	0x0060A	0
JS0OB	Interrupt pending SYSERR 0	Output	0x00608	0
JS1EB	Interrupt from SYSERR 1	Enable	0x0060A	1
JS1OB	Interrupt pending SYSERR 1	Output	0x00608	1
JS2EB	Interrupt from SYSERR 2	Enable	0x0060A	2
JS2OB	Interrupt pending SYSERR 2	Output	0x00608	2
JS3EB	Interrupt from SYSERR 3	Enable	0x0060A	3
JS3OB	Interrupt pending SYSERR 3	Output	0x00608	3
JS4EB	Interrupt from SYSERR 4	Enable	0x0060A	4
JS4OB	Interrupt pending SYSERR 4	Output	0x00608	4
JS5EB	Interrupt from SYSERR 5	Enable	0x0060A	5
JS5OB	Interrupt pending SYSERR 5	Output	0x00608	5
JS6EB	Interrupt from SYSERR 6	Enable	0x0060A	6
JS6OB	Interrupt pending SYSERR 6	Output	0x00608	6
JS7EB	Interrupt from SYSERR 7	Enable	0x0060A	7
JS7OB	Interrupt pending SYSERR 7	Output	0x00608	7
JS8EB	Interrupt from SYSERR 8	Enable	0x0060B	0
JS8OB	Interrupt pending SYSERR 8	Output	0x00609	0
JS9EB	Interrupt from SYSERR 9	Enable	0x0060B	1
JS9OB	Interrupt pending SYSERR 9	Output	0x00609	1
JSAEB	Interrupt from SYSERR A	Enable	0x0060B	2
JSAOB	Interrupt pending SYSERR A	Output	0x00609	2
JSBEB	Interrupt from SYSERR B	Enable	0x0060B	3
JSBOB	Interrupt pending SYSERR B	Output	0x00609	3
JSCEB	Interrupt from SYSERR C	Enable	0x0060B	4
JSCOB	Interrupt pending SYSERR C	Output	0x00609	4
JSDEB	Interrupt from SYSERR D	Enable	0x0060B	5
JSDOB	Interrupt pending SYSERR D	Output	0x00609	5
JSEEB	Interrupt from SYSERR E	Enable	0x0060B	6
JSEOB	Interrupt pending SYSERR E	Output	0x00609	6
JSFEB	Interrupt from SYSERR F	Enable	0x0060B	7

Appendix B. Register Bit Field Mnemonic Summary (continued)

Table 114. Mnemonic Summary, Sorted by Name (continued)

Mnemonic	Description	Type	Register	Bit Position
JSFOB	Interrupt pending SYSERR F	Output	0x00609	7
JSOSR	Interrupt SYSERR output mode	Select	0x00612	—
JSWSR	Interrupt SYSERR pulse width	Select	0x00616	—
LARSN	Local group A rate	Select	0x00320	L
LBRSN	Local group B rate	Select	0x00320	U
LC0SR	Local clock 0 output	Select	0x00228	—
LC1SR	Local clock 1 output	Select	0x00229	—
LC2SR	Local clock 2 output	Select	0x0022A	—
LC3SR	Local clock 3 output	Select	0x0022B	—
LCKEB	Local clocks	Enable	0x00103	1
LCRSN	Local group C rate	Select	0x00321	L
LDBEB	Local data bus	Enable	0x00103	0
LDRSN	Local group D rate	Select	0x00321	U
LERSN	Local group E rate	Select	0x00322	L
LFRSN	Local group F rate	Select	0x00322	U
LGRSN	Local group G rate	Select	0x00323	L
LHRSN	Local group H rate	Select	0x00323	U
LRISR	Local reference input	Select	0x00208	—
N1DSB	NR1 divider inversion	Select	0x00204	1
N1DSN	NETREF1 divider input	Select	0x00210	U
N1FEB	NETREF1 fallback trigger	Enable	0x0010B	3
N1ISN	NETREF1 main input	Select	0x00210	L
N1LOB	NETREF1 latched error	Output	0x00123	3
N1LSR	NETREF1 local reference	Select	0x00212	—
N1OEN	NETREF1 output	Enable	0x00221	L
N1SSB	NR1 selector inversion	Select	0x00204	0
N1TOB	NETREF1 transient error	Output	0x00121	3
N1WEB	NETREF1 watchdog	Enable	0x0010F	3
N1WSN	NETREF1 watchdog	Select	0x0010D	L
N2DSB	NR2 divider inversion	Select	0x00204	3
N2DSN	NETREF1 divider input	Select	0x00214	U
N2FEB	NETREF2 fallback trigger	Enable	0x0010B	4
N2ISN	NETREF1 main input	Select	0x00214	L
N2LOB	NETREF2 latched error	Output	0x00123	4
N2LSR	NETREF1 local reference	Select	0x00216	—
N2OEN	NETREF1 output	Enable	0x00221	U
N2SSB	NR2 selector inversion	Select	0x00204	2
N2TOB	NETREF2 transient error	Output	0x00121	4
N2WEB	NETREF2 watchdog	Enable	0x0010F	4
N2WSN	NETREF2 watchdog	Select	0x0010D	U

Appendix B. Register Bit Field Mnemonic Summary (continued)**Table 114. Mnemonic Summary, Sorted by Name** (continued)

Mnemonic	Description	Type	Register	Bit Position
NR1DR	NETREF1	Divide	0x00211	—
NR2DR	NETREF2	Divide	0x00215	—
OLHLR	Out-of-lock threshold, high	Load	0x00119	—
OLLLR	Out-of-lock threshold, low	Load	0x00118	—
OOLER	Out-of-lock monitor	Enable	0x0011A	—
OOLOB	Out-of-lock status	Output	0x00125	6
P1ISR	APLL1 input	Select	0x00202	—
P1RSR	APLL1 rate	Select	0x00203	—
P2RSR	APLL2 rate	Select	0x00207	—
PAFSR	Phase align frame	Enable	0x00107	—
S2FEB	/SCLKx2 fallback trigger	Enable	0x0010A	7
S2LOB	/SCLKx2 latched error	Output	0x00122	7
S2TOB	/SCLKx2 transient error	Output	0x00120	7
S2WEB	/SCLKx2 watchdog	Enable	0x0010E	7
SCFEB	SCLK fallback trigger	Enable	0x0010A	6
SCLOB	SCLK latched error	Output	0x00122	6
SCLSB	Diag state counter mode EN	Select	0x00145	3
SCMLR	Diag state counter mode low	Load	0x00144	—
SCMSB	Diag state counter carry	Select	0x00145	5
SCRSR	SCLK/SCLKx2 rate	Select	0X00227	—
SCTOB	SCLK transient error	Output	0x00120	6
SCULP	Diag state counter mode high	Load	0x00145	2:0
SCWEB	SCLK watchdog	Enable	0x0010E	6
SRBEB	Soft reset of back end	Enable	0x00101	0
SRESR	Soft reset	Select	0x00100	—
TCOSR	T clock output	Select	0x00226	—
VEROR	Version ID register	Output	0x00128	—
XYSOB	Active clock set	Output	0x00124	3

Appendix B. Register Bit Field Mnemonic Summary (continued)

Table 115. Mnemonic Summary, Sorted by Register

Mnemonic	Description	Type	Register	Bit Position
SRESR	Soft reset	Select	0x00100	—
SRBEB	Soft reset of back end	Enable	0x00101	0
HRBEB	Hard reset of back end	Enable	0x00101	1
LDBEB	Local data bus	Enable	0x00103	0
LCKEB	Local clocks	Enable	0x00103	1
HDBEB	H1x0 data bus	Enable	0x00103	2
HCKEB	H1x0 clocks	Enable	0x00103	3
GPIEB	General-purpose I/O	Enable	0x00103	4
FGREB	Frame group	Enable	0x00103	5
AIOEB	All I/O (master)	Enable	0x00103	7
GSREB	Global subrate	Enable	0x00105	7
DMMSP	Data memory mode	Select	0x00105	6:0
CSASR	Clock set access	Select	0x00106	—
FPASR	Frame phase alignment	Select	0x00107	—
PAFSR	Phase align frame	Enable	0x00107	—
FBCSR	Fallback control	Select	0x00108	—
FSMSN	Fallback secondary mode	Select	0x00109	L
FTRSN	Fallback type	Select	0x00109	U
CAFEB	C8A fallback trigger	Enable	0x0010A	0
CBFEB	C8B fallback trigger	Enable	0x0010A	1
CPFEB	/C16+ fallback trigger	Enable	0x0010A	2
CMFEB	/C16– fallback trigger	Enable	0x0010A	3
C4FEB	/C4 fallback trigger	Enable	0x0010A	4
C2FEB	C2 fallback trigger	Enable	0x0010A	5
SCFEB	SCLK fallback trigger	Enable	0x0010A	6
S2FEB	/SCLKx2 fallback trigger	Enable	0x0010A	7
FAFEB	/FRAMEA fallback trigger	Enable	0x0010B	0
FBFEB	/FRAMEB fallback trigger	Enable	0x0010B	1
FCFEB	/FR_COMP fallback trigger	Enable	0x0010B	2
N1FEB	NETREF1 fallback trigger	Enable	0x0010B	3
N2FEB	NETREF2 fallback trigger	Enable	0x0010B	4
D1FEB	DPLL1 sync trigger	Enable	0x0010B	5
D2FEB	DPLL2 sync trigger	Enable	0x0010B	6
CAWSN	C8A watchdog	Select	0x0010C	L
CBWSN	C8B watchdog	Select	0x0010C	U
N1WSN	NETREF1 watchdog	Select	0x0010D	L
N2WSN	NETREF2 watchdog	Select	0x0010D	U
CAWEB	C8A watchdog	Enable	0x0010E	0
CBWEB	C8B watchdog	Enable	0x0010E	1
CPWEB	/C16+ watchdog	Enable	0x0010E	2

Appendix B. Register Bit Field Mnemonic Summary (continued)**Table 115. Mnemonic Summary, Sorted by Register** (continued)

Mnemonic	Description	Type	Register	Bit Position
CMWEB	/C16– watchdog	Enable	0x0010E	3
C4WEB	/C4 watchdog	Enable	0x0010E	4
C2WEB	C2 watchdog	Enable	0x0010E	5
SCWEB	SCLK watchdog	Enable	0x0010E	6
S2WEB	/SCLKx2 watchdog	Enable	0x0010E	7
FAWEB	/FRAMEA watchdog	Enable	0x0010F	0
FBWEB	/FRAMEB watchdog	Enable	0x0010F	1
FCWEB	/FR_COMP watchdog	Enable	0x0010F	2
N1WEB	NETREF1 watchdog	Enable	0x0010F	3
N2WEB	NETREF2 watchdog	Enable	0x0010F	4
D1WEB	DPLL1 sync watchdog	Enable	0x0010F	5
D2WEB	DPLL2 sync watchdog	Enable	0x0010F	6
FSWEB	Failsafe watchdog	Enable	0x0010F	7
FSCSR	Failsafe return command	Select	0x00114	—
FSEER	Failsafe enable	Enable	0x00115	—
FSSSR	Failsafe sensitivity	Select	0x00116	—
OLLLR	Out-of-lock threshold, low	Load	0x00118	—
OLHLR	Out-of-lock threshold, high	Load	0x00119	—
OOLER	Out-of-lock monitor	Enable	0x0011A	—
CATOB	C8A transient error	Output	0x00120	0
CBTOB	C8B transient error	Output	0x00120	1
CPTOB	/C16+ transient error	Output	0x00120	2
CMTOB	/C16– transient error	Output	0x00120	3
C4TOB	C4 transient error	Output	0x00120	4
C2TOB	C2 transient error	Output	0x00120	5
SCTOB	SCLK transient error	Output	0x00120	6
S2TOB	/SCLKx2 transient error	Output	0x00120	7
FATOB	/FRAMEA transient error	Output	0x00121	0
FBTOB	/FRAMEB transient error	Output	0x00121	1
FCTOB	/FR_COMP transient error	Output	0x00121	2
N1TOB	NETREF1 transient error	Output	0x00121	3
N2TOB	NETREF2 transient error	Output	0x00121	4
D1TOB	DPLL1 sync transient error	Output	0x00121	5
D2TOB	DPLL2 sync transient error	Output	0x00121	6
FSTOB	Failsafe transient error	Output	0x00121	7
CALOB	C8A latched error	Output	0x00122	0
CBLOB	C8B latched error	Output	0x00122	1
CPLOB	/C16+ latched error	Output	0x00122	2
CMLOB	/C16– latched error	Output	0x00122	3
C4LOB	C4 latched error	Output	0x00122	4
C2LOB	C2 latched error	Output	0x00122	5
SCLOB	SCLK latched error	Output	0x00122	6
S2LOB	/SCLKx2 latched error	Output	0x00122	7
FALOB	/FRAMEA latched error	Output	0x00123	0

Appendix B. Register Bit Field Mnemonic Summary (continued)

Table 115. Mnemonic Summary, Sorted by Register (continued)

Mnemonic	Description	Type	Register	Bit Position
FBLOB	/FRAMEB latched error	Output	0x00123	1
FCLOB	/FR_COMP latched error	Output	0x00123	2
N1LOB	NETREF1 latched error	Output	0x00123	3
N2LOB	NETREF2 latched error	Output	0x00123	4
D1LOB	DPLL1 sync latched error	Output	0x00123	5
D2LOB	DPLL2 sync latched error	Output	0x00123	6
FSLOB	Failsafe latched error	Output	0x00123	7
FFPOB	FORCE_FALLBACK pending	Output	0x00124	0
CFPOB	CLEAR_FALLBACK pending	Output	0x00124	1
GOPOB	Go clocks pending	Output	0x00124	2
XYSOB	Active clock set	Output	0x00124	3
FBFOB	Fallback enable status	Output	0x00124	7
FBSOP	Fallback states	Output	0x00124	6:4
CFBOB	Fallback status	Output	0x00127	6
CFSOB	Failsafe status	Output	0x00127	7
VEROR	Version ID register	Output	0x00128	—
IDLOR	Device ID low	Output	0x0012A	—
IDHOR	Device ID high	Output	0x0012B	—
FT0EB	FG0 testpoint	Enable	0x00140	0
FT1EB	FG1 testpoint	Enable	0x00140	1
FT2EB	FG2 testpoint	Enable	0x00140	2
FT3EB	FG3 testpoint	Enable	0x00140	3
FT4EB	FG4 testpoint	Enable	0x00140	4
FT5EB	FG5 testpoint	Enable	0x00140	5
FT6EB	FG6 testpoint	Enable	0x00140	6
FT7EB	FG7 testpoint	Enable	0x00140	7
FTPSR	FG testpoint MUX	Select	0x00141	—
GT0EB	GP0 testpoint	Enable	0x00142	0
GT1EB	GP1 testpoint	Enable	0x00142	1
GT2EB	GP2 testpoint	Enable	0x00142	2
GT3EB	GP3 testpoint	Enable	0x00142	3
GT4EB	GP4 testpoint	Enable	0x00142	4
GT5EB	GP5 testpoint	Enable	0x00142	5
GT6EB	GP6 testpoint	Enable	0x00142	6
GT7EB	GP7 testpoint	Enable	0x00142	7
GTPSR	GP testpoint MUX	Select	0x00143	—
SCMLR	Diagnostic, state counter mode low	Load	0x00144	—
SCLSB	Diagnostic, state counter mode EN	Select	0x00145	3
FRMSB	Diagnostic, /FR_COMP input	Select	0x00145	4
SCMSB	Diagnostic, state counter carry	Select	0x00145	5
SCULP	Diagnostic, state counter mode high	Load	0x00145	2:0
FB1SB	APLL1 feedback reset	Select	0x00146	1

Appendix B. Register Bit Field Mnemonic Summary (continued)**Table 115. Mnemonic Summary, Sorted by Register** (continued)

Mnemonic	Description	Type	Register	Bit Position
FB2SB	APLL2 feedback reset	Select	0x00146	2
IEXLP	Diagnostic, interrupt control EXTERR	Load	0x00148	1:0
ISYLP	Diagnostic, interrupt control SYSERR	Load	0x00148	3:2
ICKLP	Diagnostic, interrupt control CLKERR	Load	0x00148	5:4
ICDSP	Diagnostic, interrupt control mode	Select	0x00148	7:6
IASLR	Diagnostic, SYSERR assertion	Load	0x00149	—
CFLLR	Diagnostic sync-to-frame low	Load	0x0014A	—
CFHLN	Diagnostic sync-to-frame high	Load	0x0014B	L
CFSEN	Diagnostic sync-to-frame EN	Enable	0x0014B	U
CKMSR	Clock main	Select	0x00200	—
CKMDR	Clock main	Divide	0x00201	—
P1ISR	APLL1 input	Select	0x00202	—
P1RSR	APLL1 rate	Select	0x00203	—
N1SSB	NR1 selector inversion	Select	0x00204	0
N1DSB	NR1 divider inversion	Select	0x00204	1
N2SSB	NR2 selector inversion	Select	0x00204	2
N2DSB	NR2 divider inversion	Select	0x00204	3
ICMSB	Invert clock main	Select	0x00204	4
CKRDR	Clock resource	Divide	0x00205	—
P2RSR	APLL2 rate	Select	0x00207	—
LRISR	Local reference input	Select	0x00208	—
D1ISR	DPLL1 input	Select	0x0020A	—
D1RSR	DPLL1 rate	Select	0x0020B	—
IR0SB	Invert local reference 0	Select	0x0020C	0
IR1SB	Invert local reference 1	Select	0x0020C	1
IR2SB	Invert local reference 2	Select	0x0020C	2
IR3SB	Invert local reference 3	Select	0x0020C	3
IR4SB	Invert local reference 4	Select	0x0020C	4
IR5SB	Invert local reference 5	Select	0x0020C	5
IR6SB	Invert local reference 6	Select	0x0020C	6
IR7SB	Invert local reference 7	Select	0x0020C	7
D2ISR	DPLL2 input	Select	0x0020E	—
D2RSR	DPLL2 rate	Select	0x0020F	—
N1ISN	NETREF1 main input	Select	0x00210	L
N1DSN	NETREF1 divider input	Select	0x00210	U
NR1DR	NETREF1	Divide	0x00211	—
N1LSR	NETREF1 local reference	Select	0x00212	—
N2ISN	NETREF1 main input	Select	0x00214	L
N2DSN	NETREF1 divider input	Select	0x00214	U
NR2DR	NETREF2	Divide	0x00215	—
N2LSR	NETREF1 local reference	Select	0x00216	—
CCOEN	C clocks output	Enable	0x00220	L

Appendix B. Register Bit Field Mnemonic Summary (continued)

Table 115. Mnemonic Summary, Sorted by Register (continued)

Mnemonic	Description	Type	Register	Bit Position
ABOEN	A and B clocks output	Enable	0x00220	U
N1OEN	NETREF1 output	Enable	0x00221	L
N2OEN	NETREF1 output	Enable	0x00221	U
FRWSR	/FR_COMP width	Select	0x00222	—
ACRSN	A clocks rate	Select	0x00223	L
BCRSN	B clocks rate	Select	0x00223	U
CCSEN	C clocks separate	Enable	0x00224	L
FRSEN	/FR_COMP separate	Enable	0x00224	U
TCOSR	T clock output	Select	0x00226	—
SCRSR	SCLK/SCLKx2 rate	Select	0x00227	—
LC0SR	Local clock 0 output	Select	0x00228	—
LC1SR	Local clock 1 output	Select	0x00229	—
LC2SR	Local clock 2 output	Select	0x0022A	—
LC3SR	Local clock 3 output	Select	0x0022B	—
HARSN	H1x0 group A rate	Select	0x00300	L
HBRSN	H1x0 group B rate	Select	0x00300	U
HCRSN	H1x0 group C rate	Select	0x00301	L
HDRSN	H1x0 group D rate	Select	0x00301	U
HERSN	H1x0 group E rate	Select	0x00302	L
HFRSN	H1x0 group F rate	Select	0x00302	U
HGRSN	H1x0 group G rate	Select	0x00303	L
HHRSN	H1x0 group H rate	Select	0x00303	U
LARSN	Local group A rate	Select	0x00320	L
LBRSN	Local group B rate	Select	0x00320	U
LCRSN	Local group C rate	Select	0x00321	L
LDRSN	Local group D rate	Select	0x00321	U
LERSN	Local group E rate	Select	0x00322	L
LFRSN	Local group F rate	Select	0x00322	U
LGRSN	Local group G rate	Select	0x00323	L
LHRSN	Local group H rate	Select	0x00323	U
F0LLR	Frame 0 lower start time	Load	0x00400	—
F0ULR	Frame 0 upper start time	Load	0x00401	—
F0ISB	Frame 0 pulse inversion	Enable	0x00402	7
F0WSP	Frame 0 pulse width	Select	0x00402	6:0
F0RSR	Frame 0 pulse width rate	Select	0x00403	—
F1LLR	Frame 1 lower start time	Load	0x00410	—
F1ULR	Frame 1 upper start time	Load	0x00411	—
F1ISB	Frame 1 pulse inversion	Enable	0x00412	7
F1WSP	Frame 1 pulse width	Select	0x00412	6:0
F1RSR	Frame 1 pulse width rate	Select	0x00413	—
F2LLR	Frame 2 lower start time	Load	0x00420	—
F2ULR	Frame 2 upper start time	Load	0x00421	—
F2ISB	Frame 2 pulse inversion	Enable	0x00422	7

Appendix B. Register Bit Field Mnemonic Summary (continued)**Table 115. Mnemonic Summary, Sorted by Register** (continued)

Mnemonic	Description	Type	Register	Bit Position
F2WSP	Frame 2 pulse width	Select	0x00422	6:0
F2RSR	Frame 2 pulse width rate	Select	0x00423	—
F3LLR	Frame 3 lower start time	Load	0x00430	—
F3ULR	Frame 3 upper start time	Load	0x00431	—
F3ISB	Frame 3 pulse inversion	Enable	0x00432	7
F3WSP	Frame 3 pulse width	Select	0x00432	6:0
F3RSR	Frame 3 pulse width rate	Select	0x00433	—
F4LLR	Frame 4 lower start time	Load	0x00440	—
F4ULR	Frame 4 upper start time	Load	0x00441	—
F4ISB	Frame 4 pulse inversion	Enable	0x00442	7
F4WSP	Frame 4 pulse width	Select	0x00442	6:0
F4RSR	Frame 4 pulse width rate	Select	0x00443	—
F5LLR	Frame 5 lower start time	Load	0x00450	—
F5ULR	Frame 5 upper start time	Load	0x00451	—
F5ISB	Frame 5 pulse inversion	Enable	0x00452	7
F5WSP	Frame 5 pulse width	Select	0x00452	6:0
F5RSR	Frame 5 pulse width rate	Select	0x00453	—
F6LLR	Frame 6 lower start time	Load	0x00460	—
F6ULR	Frame 6 upper start time	Load	0x00461	—
F6ISB	Frame 6 pulse inversion	Enable	0x00462	7
F6WSP	Frame 6 pulse width	Select	0x00462	6:0
F6RSR	Frame 6 pulse width rate	Select	0x00463	—
F7LLR	Frame 7 lower start time	Load	0x00470	—
F7ULR	Frame 7 upper start time	Load	0x00471	—
F7ISB	Frame 7 pulse inversion	Enable	0x00472	7
F7WSP	Frame 7 pulse width	Select	0x00472	6:0
F7RSR	Frame 7 pulse width rate	Select	0x00473	—
FCLLR	Frame group 7 lower count	Load	0x00474	—
FCULR	Frame group 7 upper count	Load	0x00475	—
F7MSR	Frame 7 mode	Select	0x00476	—
FCISB	FG7 timer invert output	Select	0x00477	7
F7WSN	FG7 timer pulse width	Select	0x00477	L
F7SSP	FG7 timer pulse shape	Select	0x00477	—
F0IOB	FGIO 0 data	Load	0x00480	0
F1IOB	FGIO 1 data	Load	0x00480	1
F2IOB	FGIO 2 data	Load	0x00480	2
F3IOB	FGIO 3 data	Load	0x00480	3
F4IOB	FGIO 4 data	Load	0x00480	4
F5IOB	FGIO 5 data	Load	0x00480	5
F6IOB	FGIO 6 data	Load	0x00480	6
F7IOB	FGIO 7 data	Load	0x00480	7
F0MEB	FGIO 0 read mask	Enable	0x00481	0
F1MEB	FGIO 1 read mask	Enable	0x00481	1
F2MEB	FGIO 2 read mask	Enable	0x00481	2

Appendix B. Register Bit Field Mnemonic Summary (continued)

Table 115. Mnemonic Summary, Sorted by Register (continued)

Mnemonic	Description	Type	Register	Bit Position
F3MEB	FGIO 3 read mask	Enable	0x00481	3
F4MEB	FGIO 4 read mask	Enable	0x00481	4
F5MEB	FGIO 5 read mask	Enable	0x00481	5
F6MEB	FGIO 6 read mask	Enable	0x00481	6
F7MEB	FGIO 7 read mask	Enable	0x00481	7
F0DSB	FGIO 0 R/W direction	Select	0x00482	0
F1DSB	FGIO 1 R/W direction	Select	0x00482	1
F2DSB	FGIO 2 R/W direction	Select	0x00482	2
F3DSB	FGIO 3 R/W direction	Select	0x00482	3
F4DSB	FGIO 4 R/W direction	Select	0x00482	4
F5DSB	FGIO 5 R/W direction	Select	0x00482	5
F6DSB	FGIO 6 R/W direction	Select	0x00482	6
F7DSB	FGIO 7 R/W direction	Select	0x00482	7
G0IOB	GPIO 0 data	Load	0x00500	0
G1IOB	GPIO 1 data	Load	0x00500	1
G2IOB	GPIO 2 data	Load	0x00500	2
G3IOB	GPIO 3 data	Load	0x00500	3
G4IOB	GPIO 4 data	Load	0x00500	4
G5IOB	GPIO 5 data	Load	0x00500	5
G6IOB	GPIO 6 data	Load	0x00500	6
G7IOB	GPIO 7 data	Load	0x00500	7
G0MEB	PIO 0 read mask	Enable	0x00501	0
G1MEB	GPIO 1 read mask	Enable	0x00501	1
G2MEB	GPIO 2 read mask	Enable	0x00501	2
G3MEB	GPIO 3 read mask	Enable	0x00501	3
G4MEB	GPIO 4 read mask	Enable	0x00501	4
G5MEB	GPIO 5 read mask	Enable	0x00501	5
G6MEB	GPIO 6 read mask	Enable	0x00501	6
G7MEB	GPIO 7 read mask	Enable	0x00501	7
G0DSB	GPIO 0 R/W direction	Select	0x00502	0
G1DSB	GPIO 1 R/W direction	Select	0x00502	1
G2DSB	GPIO 2 R/W direction	Select	0x00502	2
G3DSB	GPIO 3 R/W direction	Select	0x00502	3
G4DSB	GPIO 4 R/W direction	Select	0x00502	4
G5DSB	GPIO 5 R/W direction	Select	0x00502	5
G6DSB	GPIO 6 R/W direction	Select	0x00502	6
G7DSB	GPIO 7 R/W direction	Select	0x00502	7
G0OEB	GPIO 0 override	Enable	0x00503	0
G1OEB	GPIO 1 override	Enable	0x00503	1
JF0OB	Interrupt pending FGIO 0	Output	0x00600	0
JF1OB	Interrupt pending FGIO 1	Output	0x00600	1
JF2OB	Interrupt pending FGIO 2	Output	0x00600	2
JF3OB	Interrupt pending FGIO 3	Output	0x00600	3
JF4OB	Interrupt pending FGIO 4	Output	0x00600	4

Appendix B. Register Bit Field Mnemonic Summary (continued)**Table 115. Mnemonic Summary, Sorted by Register** (continued)

Mnemonic	Description	Type	Register	Bit Position
JF5OB	Interrupt pending FGIO 5	Output	0x00600	5
JF6OB	Interrupt pending FGIO 6	Output	0x00600	6
JF7OB	Interrupt pending FGIO 7	Output	0x00600	7
JF0EB	Interrupt from FGIO 0	Enable	0x00601	0
JF1EB	Interrupt from FGIO 1	Enable	0x00601	1
JF2EB	Interrupt from FGIO 2	Enable	0x00601	2
JF3EB	Interrupt from FGIO 3	Enable	0x00601	3
JF4EB	Interrupt from FGIO 4	Enable	0x00601	4
JF5EB	Interrupt from FGIO 5	Enable	0x00601	5
JF6EB	Interrupt from FGIO 6	Enable	0x00601	6
JF7EB	Interrupt from FGIO 7	Enable	0x00601	7
IF0SB	Invert interrupt FGIO 0	Select	0x00603	0
IF1SB	Invert interrupt FGIO 1	Select	0x00603	1
IF2SB	Invert interrupt FGIO 2	Select	0x00603	2
IF3SB	Invert interrupt FGIO 3	Select	0x00603	3
IF4SB	Invert interrupt FGIO 4	Select	0x00603	4
IF5SB	Invert interrupt FGIO 5	Select	0x00603	5
IF6SB	Invert interrupt FGIO 6	Select	0x00603	6
IF7SB	Invert interrupt FGIO 7	Select	0x00603	7
JG0OB	Interrupt pending GPIO 0	Output	0x00604	0
JG1OB	Interrupt pending GPIO 1	Output	0x00604	1
JG2OB	Interrupt pending GPIO 2	Output	0x00604	2
JG3OB	Interrupt pending GPIO 3	Output	0x00604	3
JG4OB	Interrupt pending GPIO 4	Output	0x00604	4
JG5OB	Interrupt pending GPIO 5	Output	0x00604	5
JG6OB	Interrupt pending GPIO 6	Output	0x00604	6
JG7OB	Interrupt pending GPIO 7	Output	0x00604	7
JG0EB	Interrupt from GPIO 0	Enable	0x00605	0
JG1EB	Interrupt from GPIO 1	Enable	0x00605	1
JG2EB	Interrupt from GPIO 2	Enable	0x00605	2
JG3EB	Interrupt from GPIO 3	Enable	0x00605	3
JG4EB	Interrupt from GPIO 4	Enable	0x00605	4
JG5EB	Interrupt from GPIO 5	Enable	0x00605	5
JG6EB	Interrupt from GPIO 6	Enable	0x00605	6
JG7EB	Interrupt from GPIO 7	Enable	0x00605	7
IG0SB	Invert interrupt GPIO 0	Select	0x00607	0
IG1SB	Invert interrupt GPIO 1	Select	0x00607	1
IG2SB	Invert interrupt GPIO 2	Select	0x00607	2
IG3SB	Invert interrupt GPIO 3	Select	0x00607	3
IG4SB	Invert interrupt GPIO 4	Select	0x00607	4
IG5SB	Invert interrupt GPIO 5	Select	0x00607	5
IG6SB	Invert interrupt GPIO 6	Select	0x00607	6
IG7SB	Invert interrupt GPIO 7	Select	0x00607	7

Appendix B. Register Bit Field Mnemonic Summary (continued)

Table 115. Mnemonic Summary, Sorted by Register (continued)

Mnemonic	Description	Type	Register	Bit Position
JS0OB	Interrupt pending SYSERR 0	Output	0x00608	0
JS1OB	Interrupt pending SYSERR 1	Output	0x00608	1
JS2OB	Interrupt pending SYSERR 2	Output	0x00608	2
JS3OB	Interrupt pending SYSERR 3	Output	0x00608	3
JS4OB	Interrupt pending SYSERR 4	Output	0x00608	4
JS5OB	Interrupt pending SYSERR 5	Output	0x00608	5
JS6OB	Interrupt pending SYSERR 6	Output	0x00608	6
JS7OB	Interrupt pending SYSERR 7	Output	0x00608	7
JS8OB	Interrupt pending SYSERR 8	Output	0x00609	0
JS9OB	Interrupt pending SYSERR 9	Output	0x00609	1
JSAOB	Interrupt pending SYSERR A	Output	0x00609	2
JSBOB	Interrupt pending SYSERR B	Output	0x00609	3
JSCOB	Interrupt pending SYSERR C	Output	0x00609	4
JSDOB	Interrupt pending SYSERR D	Output	0x00609	5
JSEOB	Interrupt pending SYSERR E	Output	0x00609	6
JSFOB	Interrupt pending SYSERR F	Output	0x00609	7
JS0EB	Interrupt from SYSERR 0	Enable	0x0060A	0
JS1EB	Interrupt from SYSERR 1	Enable	0x0060A	1
JS2EB	Interrupt from SYSERR 2	Enable	0x0060A	2
JS3EB	Interrupt from SYSERR 3	Enable	0x0060A	3
JS4EB	Interrupt from SYSERR 4	Enable	0x0060A	4
JS5EB	Interrupt from SYSERR 5	Enable	0x0060A	5
JS6EB	Interrupt from SYSERR 6	Enable	0x0060A	6
JS7EB	Interrupt from SYSERR 7	Enable	0x0060A	7
JS8EB	Interrupt from SYSERR 8	Enable	0x0060B	0
JS9EB	Interrupt from SYSERR 9	Enable	0x0060B	1
JSAEB	Interrupt from SYSERR A	Enable	0x0060B	2
JSBEB	Interrupt from SYSERR B	Enable	0x0060B	3
JSCEB	Interrupt from SYSERR C	Enable	0x0060B	4
JSDEB	Interrupt from SYSERR D	Enable	0x0060B	5
JSEEB	Interrupt from SYSERR E	Enable	0x0060B	6
JSFEB	Interrupt from SYSERR F	Enable	0x0060B	7
JC0OB	Interrupt pending CLKERR 0	Output	0x0060C	0
JC1OB	Interrupt pending CLKERR 1	Output	0x0060C	1
JC2OB	Interrupt pending CLKERR 2	Output	0x0060C	2
JC3OB	Interrupt pending CLKERR 3	Output	0x0060C	3
JC4OB	Interrupt pending CLKERR 4	Output	0x0060C	4
JC5OB	Interrupt pending CLKERR 5	Output	0x0060C	5
JC6OB	Interrupt pending CLKERR 6	Output	0x0060C	6
JC7OB	Interrupt pending CLKERR 7	Output	0x0060C	7
JC8OB	Interrupt pending CLKERR 8	Output	0x0060D	0
JC9OB	Interrupt pending CLKERR 9	Output	0x0060D	1
JCAOB	Interrupt pending CLKERR A	Output	0x0060D	2

Appendix B. Register Bit Field Mnemonic Summary (continued)**Table 115. Mnemonic Summary, Sorted by Register** (continued)

Mnemonic	Description	Type	Register	Bit Position
JCBOB	Interrupt pending CLKERR B	Output	0x0060D	3
JCCOB	Interrupt pending CLKERR C	Output	0x0060D	4
JCDOB	Interrupt pending CLKERR D	Output	0x0060D	5
JCEOB	Interrupt pending CLKERR E	Output	0x0060D	6
JCFOB	Interrupt pending CLKERR F	Output	0x0060D	7
JC0EB	Interrupt from CLKERR 0	Enable	0x0060E	0
JC1EB	Interrupt from CLKERR 1	Enable	0x0060E	1
JC2EB	Interrupt from CLKERR 2	Enable	0x0060E	2
JC3EB	Interrupt from CLKERR 3	Enable	0x0060E	3
JC4EB	Interrupt from CLKERR 4	Enable	0x0060E	4
JC5EB	Interrupt from CLKERR 5	Enable	0x0060E	5
JC6EB	Interrupt from CLKERR 6	Enable	0x0060E	6
JC7EB	Interrupt from CLKERR 7	Enable	0x0060E	7
JC8EB	Interrupt from CLKERR 8	Enable	0x0060F	0
JC9EB	Interrupt from CLKERR 9	Enable	0x0060F	1
JCAEB	Interrupt from CLKERR A	Enable	0x0060F	2
JCBEB	Interrupt from CLKERR B	Enable	0x0060F	3
JCCEB	Interrupt from CLKERR C	Enable	0x0060F	4
JCDEB	Interrupt from CLKERR D	Enable	0x0060F	5
JCEEB	Interrupt from CLKERR E	Enable	0x0060F	6
JCFEB	Interrupt from CLKERR F	Enable	0x0060F	7
JAMSR	Interrupt arbitration mode	Select	0x00610	—
JSOSR	Interrupt SYSERR output mode	Select	0x00612	—
JCOSR	Interrupt CLKERR output mode	Select	0x00613	—
JSWSR	Interrupt SYSERR pulse width	Select	0x00616	—
JCWSR	Interrupt CLKERR pulse width	Select	0x00617	—
JISOR	Interrupt in-service	Output	0x006FC	—

Significant Changes Between the June 2003 and November 2003 Release

Changes that were made to this document (since Revision 3) are listed below.

Table 116. Changes

Page	Description
page 11	Added PEN, TESTMODE Interface Signals to Table 6.
page 17	Added PEN, TESTMODE pins to Table 8.
page 126	Added Thermal Parameters definitions and values.
page 133	Removed signals listed as no connects.
page 141	Changed boundary of Constant Delay Rev Connections.

Motorola is a registered trademark of Motorola, Inc.
Intel is a registered trademark of Intel Corporation.
AT&T is a registered trademark of AT&T Corporation.
CompactPCI is a registered trademark of the PCI Industrial Computer Manufacturers Group.
MVIP is a trademark of Natural MicroSystems Corporation.
IEEE is a registered trademark of The Institute of Electrical and Electronic Engineers, Inc.

For additional information, contact your Agere Systems Account Manager or the following:

INTERNET: <http://www.agere.com>

E-MAIL: docmaster@agere.com

N. AMERICA: Agere Systems Inc., Lehigh Valley Central Campus, Room 10A-301C, 1110 American Parkway NE, Allentown, PA 18109-91386

1-800-372-2447, FAX 610-712-4106 (In CANADA: **1-800-553-2448**, FAX 610-712-4106)

ASIA: Agere Systems Hong Kong Ltd., Suites 3201 & 3210-12, 32/F, Tower 2, The Gateway, Harbour City, Kowloon

Tel. (852) 3129-2000, FAX (852) 3129-2020

CHINA: **(86) 21-54614688** (Shanghai), **(86) 755-25881122** (Shenzhen)

JAPAN: **(81) 3-5421-1600** (Tokyo), KOREA: **(82) 2-767-1850** (Seoul), SINGAPORE: **(65) 778-8833**, TAIWAN: **(886) 2-2725-5858** (Taipei)

EUROPE: **Tel. (44) 7000 624624**, FAX (44) 1344 488 045

Agere Systems Inc. reserves the right to make changes to the product(s) or information contained herein without notice. No liability is assumed as a result of their use or application.
Agere, Agere Systems, the Agere logo are trademarks and *Ambassador* is a registered trademark of Agere Systems Inc.

Copyright © 2004 Agere Systems Inc.
All Rights Reserved

February 2004
DS04-024SWCH (Replaces DS03-132SWCH and AY03-020SWCH)

agere systems