

**PART NUMBER**

CSM100 / CSM101

**COMPONENT SPECIFICATION**

Issue 9

## ***Component Specification for Ceramic Hermetically Sealed, Radiation Hard Transistor Optocoupler***

Features	Applications
<ul style="list-style-type: none"> <li>▪ Released to European standard and complies to MIL-STD</li> <li>▪ Total Ionizing Dose tested to 150 Krad(si)</li> <li>▪ Displacement Damage tested to 1 MeV x 10<sup>13</sup></li> <li>▪ Withstand test voltage of 1,000V<sub>DC</sub></li> <li>▪ LCC-4 Package</li> <li>▪ Low Input Requirements</li> <li>▪ High Current Ratio</li> <li>▪ Hermetically Sealed</li> <li>▪ Small outline package for surface mount</li> </ul>	<ul style="list-style-type: none"> <li>▪ Space equipment and systems</li> <li>▪ Military equipment and systems</li> <li>▪ Medical instruments</li> <li>▪ MOS/CMOS applications</li> <li>▪ Logic interfacing</li> <li>▪ Data transmission</li> <li>▪ Power supply</li> <li>▪ Modems</li> </ul>

### **DESCRIPTION**

These devices are single channel, hermetically sealed and optically coupled isolators. They are composed of an infrared emitting diode and a silicon phototransistor.

The CSM100 is being used in environments encountered by space applications. It is manufactured to meet JANS standards in conjunction with MIL-PRF-19500 procedures (please see next page for all other applicable specifications). Package styles for this device include an LCC-4 package, with solder dip option available.

Absolute maximum ratings, recommended operating conditions, electrical specifications and performance characteristics are identical for all units. Any exceptions, due to packaging variations and limitations, are as noted.



M1077 & E1280/F



GB15/92780



0005



aerospace  
sector  
certification  
scheme

For sales enquiries, or further information, please contact our sales office at:

ISOCOM Limited • 48 Hutton Close • Crowther • Washington • Tyne & Wear • NE38 0AH • United Kingdom  
Email: [sales@isocom.uk.com](mailto:sales@isocom.uk.com) • Tel: +44 (0)191 416 6546 • Fax: +44 (0)191 415 5055

## STANDARDS

The following specifications have been complied with in the manufacturing of this product:

### Aerospace Compliance Standards

AS9100D / ISO 9001:2015 – Design & Manufacture of Electronic and Optoelectronic Components (*Ref GB15/92780*)

IECQ Approved Process Manufacturer (*Ref M1077*)

IECQ Qualification (*Ref E1280/F*)

### Military Compliance Specifications

MIL-PRF-19500 – General Specification for Discrete Semiconductor Devices

### Military Compliance Standards

MIL-STD-202 – Test Method Standard Electronic and Electrical Component Parts

MIL-STD-883 – Test Method Standard Microcircuits

MIL-STD-750 – Test Methods for Semiconductor Devices

## AMENDMENT RECORD

Issue 1 – 24/07/2014 – Added CSM101 to the datasheet

Issue 2 – 01/10/2015 – Added Displacement Damage and TID data

Issue 3 – 24/02/2016 – Changed layout of the datasheet

Issue 4 – 01/04/2016 – Added Pin 1 indicator on outline drawing page 4

Issue 5 – 13/02/2017 – Document reformatted

Issue 6 – 21/02/2017 – Added CSM102

Issue 7 – 12/12/2017 – Removed Displacement Damage and TID data (available as separate document)

Issue 8 – 23/04/2018 – Updated quality standards

Issue 9 – 22/05/2018 – Updated circuit and package diagrams. Removed CSM102.

For sales enquiries, or further information, please contact our sales office at:

ISOCOM Limited • 48 Hutton Close • Crowther • Washington • Tyne & Wear • NE38 0AH • United Kingdom  
Email: [sales@isocom.uk.com](mailto:sales@isocom.uk.com) • Tel: +44 (0)191 416 6546 • Fax: +44 (0)191 415 5055

## SELECTION GUIDE PACKAGE STYLES AND CONFIGURATION OPTIONS

ISOCOM Part Number and Options	
Package	4-pin LCC
Channels	1
Commercial	CSM100 CSM101
Defense Screen Level	CSM100/L2 CSM101/L2
Space Screen Level	CSM100/L2S CSM101/L2S
Standard Finish	Gold Plating
Solder Dipped	Option 20

## FUNCTIONAL DIAGRAMS

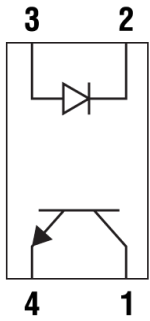
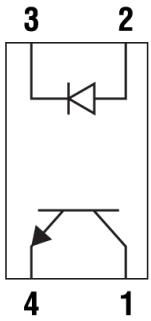
CSM100	CSM101
4-pin LCC	4-pin LCC
1 Channel	1 Channel
 <p style="text-align: center;">Top View</p>	 <p style="text-align: center;">Top View</p>

## DEVICE MARKING

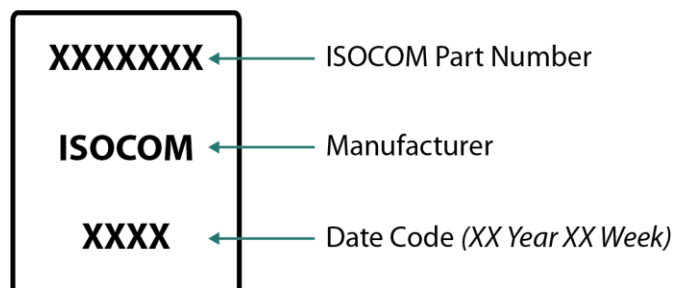

For sales enquiries, or further information, please contact our sales office at:

ISOCOM Limited • 48 Hutton Close • Crowther • Washington • Tyne & Wear • NE38 0AH • United Kingdom  
 Email: [sales@isocom.uk.com](mailto:sales@isocom.uk.com) • Tel: +44 (0)191 416 6546 • Fax: +44 (0)191 415 5055

## OUTLINE DRAWINGS

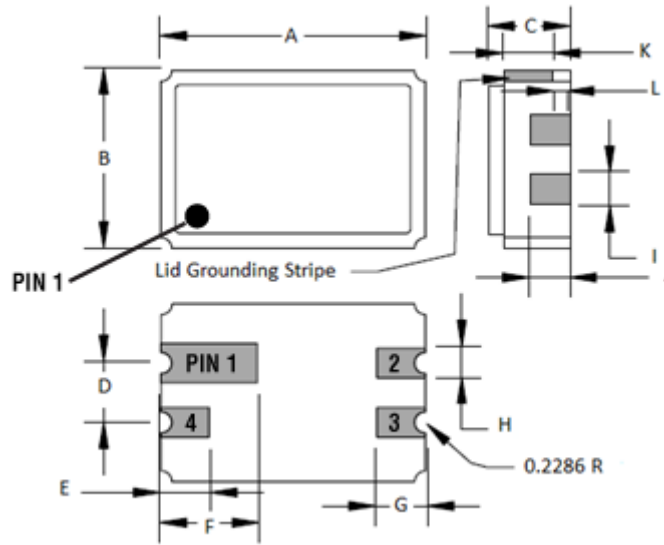

## DIMENSIONS

SYMBOL	INCHES		MILLIMETRES	
	MIN	MAX	MIN	MAX
A	0.215	0.225	5.46	5.71
B	0.145	0.155	3.68	3.94
C	0.061	0.075	1.55	1.91
D	0.045	0.055	1.14	1.40
E	0.032	0.048	0.81	1.22
F	0.072	0.088	1.83	2.24
G	0.032	0.048	0.81	1.22
H	0.022	0.028	0.56	0.71
I	0.010	0.024	0.25	0.61
J	0.029	0.044	0.74	1.12
K	0.036	0.044	0.91	1.12
L	0.011	0.019	0.28	0.48

For sales enquiries, or further information, please contact our sales office at:

ISOCOM Limited • 48 Hutton Close • Crowther • Washington • Tyne & Wear • NE38 0AH • United Kingdom  
 Email: [sales@isocom.uk.com](mailto:sales@isocom.uk.com) • Tel: +44 (0)191 416 6546 • Fax: +44 (0)191 415 5055

## SWITCHING TIME

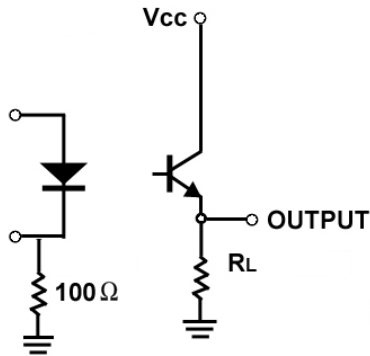
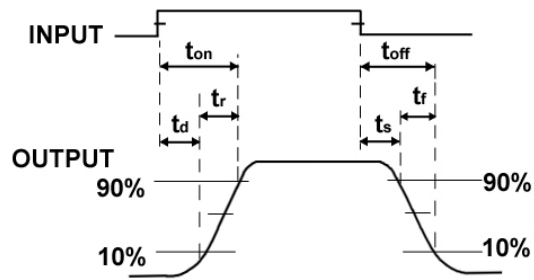

FIG 1



## ABSOLUTE MAXIMUM RATINGS

TA 25°C U.O.S.

Storage Temperature	-65°C to +150°C	
Operating Temperature	-55°C to +125°C	
Lead Soldering Temperature	260°C 1.6mm from case for 10S	
Input-to-Output Isolation Voltage	↑1000VDC	
<b>Input Diode</b>		
Forward DC Current	40mA	DC at (or below) +65°C Derates linearly to +125°C free air temperature at the rate of 0.67mA/°C.
Reverse DC Voltage	2V	
Peak forward Current	1.0A	Pw≤1μS, PRR<300pps ≤ 10μS ms
Power Dissipation	60mW	Derates linearly above 65°C at 1.0W/°C
<b>Output Transistor</b>		
Collector-Emitter Voltage	40V	
Emitter-Collector Voltage	5V	
Collector Current	50mA	
Power Dissipation	300mW	Derate linearly above 25°C at 3.0W/°C
<b>Coupled Device</b>		
Input to Output Isolation Voltage	1000V	
Power Dissipation	360mW	
Soldering Temperature, Soldering Iron	260, 5	°C This part shall not be re-soldered until 3 minutes have elapsed.
Soldering Temperature, Vapour Phase	220, 40	°C This part shall not be re-soldered until 3 minutes have elapsed.
ESD Classification	Class 2	Class 2 with minimum critical path voltage of 4,000 to 15,999V. MIL-STD-883

For sales enquiries, or further information, please contact our sales office at:

ISOCOM Limited • 48 Hutton Close • Crowther • Washington • Tyne & Wear • NE38 0AH • United Kingdom  
 Email: [sales@isocom.uk.com](mailto:sales@isocom.uk.com) • Tel: +44 (0)191 416 6546 • Fax: +44 (0)191 415 5055

## ELECTRICAL CHARACTERISTICS

$T_A = 25^\circ\text{C}$  U.O.S.

PARAMETER	SYMBOL	TEST CONDITIONS	MIN	TYP	MAX	UNITS
Forward Voltage	$V_F$	$I_F = 10\text{mA}$	1.3	-	1.6	V
		$I_F = 10\text{mA}$ $-55^\circ\text{C}$	1.3	-	1.8	V
		$I_F = 10\text{mA}$ $+125^\circ\text{C}$	1.1	-	1.6	V
Reverse Current	$I_R$	$V_R = 2.0\text{V}$	-	-	100	$\mu\text{A}$
<b>Output Detector Electrical Characteristics</b>						
Collector-Emitter Breakdown Voltage	$V(\text{BR})_{\text{CEO}}$	$I_C = 1\text{mA}$	70	100	-	V
Emitter-Collector Breakdown Voltage	$V(\text{BR})_{\text{ECO}}$	$I_E = 0.1\text{mA}$	7	9	-	V
Collector-Emitter Leakage Current	$I_{\text{CEO}}$	$V_{\text{CE}} = 20\text{V}$ , $I_F = 0$	-	7	100	$\mu\text{A}$
		$V_{\text{CE}} = 20\text{V}$ $I_F = 0$ , $-55^\circ\text{C}$	-	-	100	$\mu\text{A}$
		$V_{\text{CE}} = 20\text{V}$ , $I_F = 0$ , $+125^\circ\text{C}$	-	10	150	$\mu\text{A}$
<b>Coupled Electrical Characteristics</b>						
DC Current Transfer Ratio	$I_C/I_F$	$I_F = 1.0\text{mA}$ , $V_{\text{CE}} = 1\text{V}$	200	-	-	%
		$I_F = 3.0\text{mA}$ , $V_{\text{CE}} = 1\text{V}$	200	-	-	%
		$I_F = 15.0\text{mA}$ , $V_{\text{CE}} = 1\text{V}$	100	-	-	%
		$I_F = 10.0\text{mA}$ , $V_{\text{CE}} = 5\text{V}$ (Note 1)	350	-	-	%
		$I_F = 15.0\text{mA}$ , $V_{\text{CE}} = 5\text{V}$ (Note 1)	100	-	-	%
		$I_F = 1.0\text{mA}$ , $V_{\text{CE}} = 15\text{V}$	300	-	-	%
Collector-Emitter Saturation Voltage	$V_{\text{CE}}(\text{Sat})$	$I_C = 10.0\text{mA}$ $I_F = 20\text{mA}$	-	-	0.22	V
Isolation Voltage	V in-out	$T = 5\text{s}$ (Note 2)	1000	-	-	Vdc
Input to Output Resistance	R in-out	$V_{\text{IO}} = 500\text{V}$ (Note 2)	-	$10^5$	-	$\Omega$
Rise Time	$t_r$	$R_L = 100\Omega$ $V_{\text{CC}} = 10\text{V}$ $I_F = 10\text{mA}$	-	-	20	$\mu\text{s}$
Fall Time	$t_f$	$R_L = 100\Omega$ $V_{\text{CC}} = 10\text{V}$ $I_F = 10\text{mA}$	-	-	20	$\mu\text{s}$
Propagation Delay H-L	$t_{\text{PHL}}$	$R_L = 100\Omega$ $V_{\text{CC}} = 10\text{V}$ $I_F = 10\text{mA}$	-	-	5.0	$\mu\text{s}$
Propagation Delay L-H	$t_{\text{PLH}}$	$R_L = 100\Omega$ $V_{\text{CC}} = 10\text{V}$ $I_F = 10\text{mA}$	-	-	5.0	$\mu\text{s}$
DC Current Transfer Ratio	$I_C(\text{CTR})$ (note 1)	$I_F = 1.0\text{mA}$ , $V_{\text{CE}} = 1\text{V}$ , $T_A = 125^\circ\text{C}$	200	-	-	%
		$I_F = 1.0\text{mA}$ , $V_{\text{CE}} = 1\text{V}$ , $T_A = -55^\circ\text{C}$	200	-	-	%
		$I_F = 3.0\text{mA}$ , $V_{\text{CE}} = 1\text{V}$ , $T_A = 125^\circ\text{C}$	100	-	-	%
		$I_F = 3.0\text{mA}$ , $V_{\text{CE}} = 1\text{V}$ , $T_A = -55^\circ\text{C}$	100	-	-	%
		$I_F = 15.0\text{mA}$ , $V_{\text{CE}} = 1\text{V}$ , $T_A = 125^\circ\text{C}$	66	-	-	%
		$I_F = 15.0\text{mA}$ , $V_{\text{CE}} = 1\text{V}$ , $T_A = -55^\circ\text{C}$	66	-	-	%
		$I_F = 10.0\text{mA}$ , $V_{\text{CE}} = 5\text{V}$ ; $T_A = 125^\circ\text{C}$	160	-	-	%
		$I_F = 10.0\text{mA}$ , $V_{\text{CE}} = 5\text{V}$ , $T_A = -55^\circ\text{C}$	160	-	-	%
		$I_F = 15.0\text{mA}$ , $V_{\text{CE}} = 5\text{V}$ , $T_A = 125^\circ\text{C}$	40	-	-	%
		$I_F = 15.0\text{mA}$ , $V_{\text{CE}} = 5\text{V}$ , $T_A = -55^\circ\text{C}$	40	-	-	%
		$I_F = 1.0\text{mA}$ , $V_{\text{CE}} = 15\text{V}$ , $T_A = 125^\circ\text{C}$	250	-	-	%
		$I_F = 1.0\text{mA}$ , $V_{\text{CE}} = 15\text{V}$ , $T_A = -55^\circ\text{C}$	250	-	-	%

### Notes

- Sample and hold pulse shall not be longer than 0.1 seconds. Duty cycle shall be 10.
- Measurements with inputs shorted together and outputs shorted together.

For sales enquiries, or further information, please contact our sales office at:

ISOCOM Limited • 48 Hutton Close • Crowther • Washington • Tyne & Wear • NE38 0AH • United Kingdom  
Email: [sales@isocom.uk.com](mailto:sales@isocom.uk.com) • Tel: +44 (0)191 416 6546 • Fax: +44 (0)191 415 5055

## GROUP TESTING to MIL-STD 750

GROUP	TEST	MIL-STD-750	READ AND RECORD
<b>Group A</b>			
SG1	Visual inspection & mechanical dimensions	Method 2071	
SG2	DC static test at 25°C		yes
SG3	DC static test at 125°C and -55°C		yes
SG4	Dynamic test at 25°C		yes
<b>Group B</b>			
SG 1	Physical dimensions	Method 2066	
SG 2	Solderability	Method 2026	
	Resistance to solvents	Method 1022	
SG 3	Thermal Shock	Method 1056 Cond. B, 25 cycles	
	Temperature cycling	Method 1051, -55/+125°C	
	Hermetic seal fine and gross leak	Method 1071, Cond. H (fine), Cond. C (gross)	
	<b>Electrical measurement</b>	pre and post	yes
	Decap internal visual inspection	2075	
	<b>Bond strength</b>	Method 2037, Cond. D	yes
	<b>Die shear</b>	Method 2017	yes
SG 4	Intermittent operation life	Method 1037, 1042, Cond D, Tab.5-5	
	Hermetic seal fine and gross leak	Method 1071, Cond. H (fine), Cond. C (gross)	
	<b>Electrical measurement</b>	pre and post	yes
	<b>Bond strength</b>	Method 2037, Cond. D	yes
SG 5	Acc. steady-state operation life	Method 1027	
	<b>Electrical measurement</b>	pre and post	yes
	<b>Bond strength</b>	Method 2037, Cond. D	yes
<b>Group C</b>			
SG 2	Thermal Shock	Method 1056, Cond. B, 25 shocks	
	Temperature cycling	Method 1051, Cond. C, -55/+125°C , 25 cycles (total 45 cycles including screening)	
	Hermetic seal fine and gross leak	Method 1071, Cond. H (fine), Cond. C (gross)	
	Moisture resistance	Method 1021	
	<b>Electrical measurement</b>	pre and post	yes
SG 3	Mechanical shock	Method 2016, non-operating, 1500 G, 0.5 ms, 5 blows in each orientation (X1,Y1,Z1)	
	Vibration	Method 2056	
	Constant acceleration	Method 2006, at a peak level of 5000 G	
	<b>Electrical measurement</b>	pre and post	yes
SG 6	Steady state operating life Not required as B5 is available on same lot		

For sales enquiries, or further information, please contact our sales office at:

ISOCOM Limited • 48 Hutton Close • Crowther • Washington • Tyne & Wear • NE38 0AH • United Kingdom  
 Email: [sales@isocom.uk.com](mailto:sales@isocom.uk.com) • Tel: +44 (0)191 416 6546 • Fax: +44 (0)191 415 5055

## 100% SCREENING to MIL-STD 750

TEST	MIL-STD-750	READ AND RECORD
Internal Visual	2072	
<b>Sealing</b>		
(Fine Leak)	1071, Condition H1	
(Gross Leak)	1071, Condition C	
Temp Cycling	1051, Condition B-55/+125°C, 20 Cycles	
Const. Acceler	2006, 5000G, Y1 only	
PIND	2052, Condition A	
Radiography	2076	
Initial Electrical	125°C, -55°C, 25°C	R & R
HTRB	1039	
Interim Electrical	25°C only	R & R
Burn-In	1039	
Final Electrical	125°C, -55°C, 25°C	R & R
PDA	Max. 5%, pre/post B1 electrical and delta at RT only	Calculate & R
(Fine Leak)	1071, Condition H1	
(Gross Leak)	1071, Condition C	
<b>Solder Dip</b>		
Fine Leak	1071, Condition H1	
Gross Leak	1071, Condition C	

For sales enquiries, or further information, please contact our sales office at:

ISOCOM Limited • 48 Hutton Close • Crowther • Washington • Tyne & Wear • NE38 0AH • United Kingdom  
 Email: [sales@isocom.uk.com](mailto:sales@isocom.uk.com) • Tel: +44 (0)191 416 6546 • Fax: +44 (0)191 415 5055

## Space Qualification PROCESS FLOW CHART FOR PACKAGED DEVICES

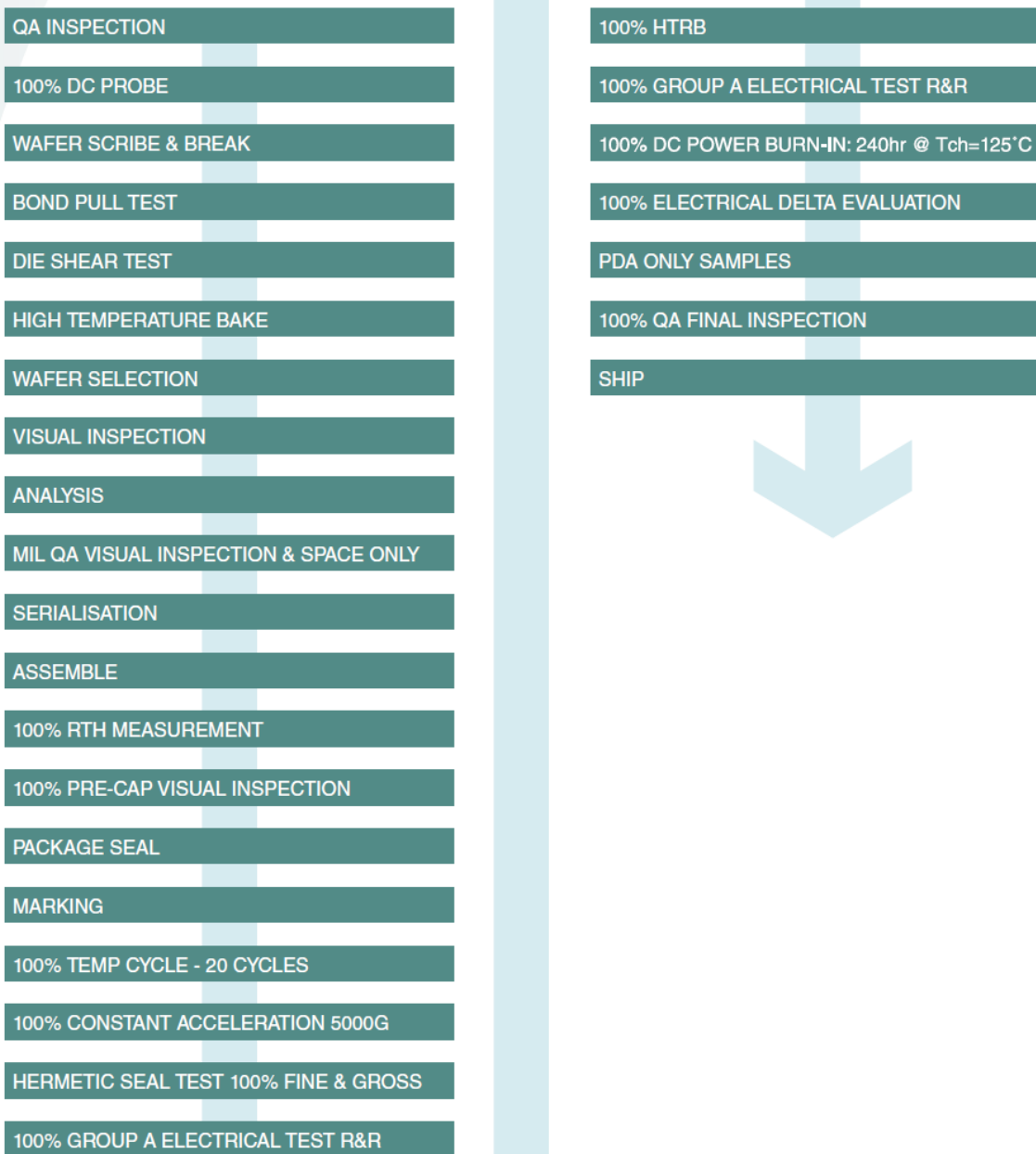

For sales enquiries, or further information, please contact our sales office at:

ISOCOM Limited • 48 Hutton Close • Crowther • Washington • Tyne & Wear • NE38 0AH • United Kingdom  
 Email: [sales@isocom.uk.com](mailto:sales@isocom.uk.com) • Tel: +44 (0)191 416 6546 • Fax: +44 (0)191 415 5055

## Space Qualification

### PROCESS FLOW CHART FOR PACKAGED DEVICES

Group B Testing	*MIL-STD-883	*MIL-STD-750
Physical Dimensions	Method 2016	Method 2066
Solderability	Method 2003	Method 2023
Resistance to Solvents	Method 2015	Method 1022
Temperature Cycling	Method 1010	Method 1051
• <i>Military Grade</i>	25 cycles	25 cycles
• <i>Space Grade</i>	50 cycles	50 cycles
Steady State Life (Tch 175°C / 340hr minimum)	Method 1005	Method 1027
DPA	*MIL-STD-1580A	*MIL-STD-1580A
	*Unless otherwise indicated	*Unless otherwise indicated

Environmental & Mechanical Testing Specifications		
	*MIL-STD-883	*MIL-STD-750
Hermetic Seal Test	Method 1014	Method 1071
• <i>Fine Leak</i>	Condition A1	Condition G or H
• <i>Gross Leak</i>	Condition C	Method 1051
Temperature Cycle ( <i>Standard Military Level</i> )	Method 1010, Condition C	Method 1051, Condition C
Temperature Cycle ( <i>Standard Space Level</i> )	Method 1010, Condition C	Method 1051, Condition C
Constant Acceleration	Method 2001	Method 2006
PIND Test	Method 2020	Method 2052, Condition A
RTH Measurement	Method 1012	
HTRB ( <i>High Temperature Reverse Bias</i> )	Method 1015, Condition A	Method 1042, Condition B
DPA	*MIL-STD-1580A	*MIL-STD-1580A
	*Unless otherwise indicated	*Unless otherwise indicated

Inspection Table		
COMMERCIAL	MILITARY	HI-REL / SPACE
AQL Sampling Plan	MIL-STD-883, Method 2010, Class Level B	MIL-STD-883, Method 2010, Class Level S
Isocom Internal Specifications	MIL-STD-750, Method 2070, 2071,2072	MIL-STD-750, Method 2070, 2071,2072

For sales enquiries, or further information, please contact our sales office at:

ISOCOM Limited • 48 Hutton Close • Crowther • Washington • Tyne & Wear • NE38 0AH • United Kingdom  
 Email: [sales@isocom.uk.com](mailto:sales@isocom.uk.com) • Tel: +44 (0)191 416 6546 • Fax: +44 (0)191 415 5055

## DISCLAIMER

The information provided on the datasheet is for preliminary and general information only. We do not warrant that the information contained on the datasheet is suitable for your intended use, nor do we accept responsibility for loss suffered as a result of reliance by you upon the accuracy or currency of information contained on the datasheet. In particular, you should not make any investment or commercial decision on the basis of the information contained on the datasheet. You should obtain independent professional advice and make your own further enquiries before making any investment or commercial decision or taking any further action in any way related to the information contained on the datasheet.

We are not aware of any inaccuracy in the information contained on the datasheet. However, we do not warrant the accuracy, adequacy or completeness of such information.

We reserve the right to remove or alter any of the information contained on the datasheet at any time. However, we do not guarantee the currency of the information contained on the datasheet, nor do we undertake to keep the datasheet updated.

### ISOCOM Limited

48 Hutton Close  
Crowther  
Washington  
Tyne & Wear  
NE38 0AH  
United Kingdom

T: +44 (0)191 416 6546  
F: +44 (0)191 415 5055  
E: [sales@isocom.uk.com](mailto:sales@isocom.uk.com)

[www.isocom.uk.com](http://www.isocom.uk.com)



M1077 & E1280/F



GB15/92780



0005



aerospace  
sector  
certification  
scheme

For sales enquiries, or further information, please contact our sales office at:

ISOCOM Limited • 48 Hutton Close • Crowther • Washington • Tyne & Wear • NE38 0AH • United Kingdom  
Email: [sales@isocom.uk.com](mailto:sales@isocom.uk.com) • Tel: +44 (0)191 416 6546 • Fax: +44 (0)191 415 5055