

L1PTR-C



TNC Male Right Angle for 1/4 in LDF1-50 cable

OBSOLETE

Product Classification

Product Type	Wireless and radiating connector
Product Brand	HELIAX®

General Specifications

Body Style	Right angle
Cable Family	LDF1-50
Inner Contact Attachment Method	Captivated
Inner Contact Plating	Silver
Interface	TNC Male
Mounting Angle	Right angle
Outer Contact Attachment Method	Self-flare
Outer Contact Plating	Trimetal
Pressurizable	No

Dimensions

Height	31.24 mm 1.23 in
Length	59.44 mm 2.34 in
Diameter	16.51 mm 0.65 in
Nominal Size	1/4 in

Outline Drawing

L1PTR-C

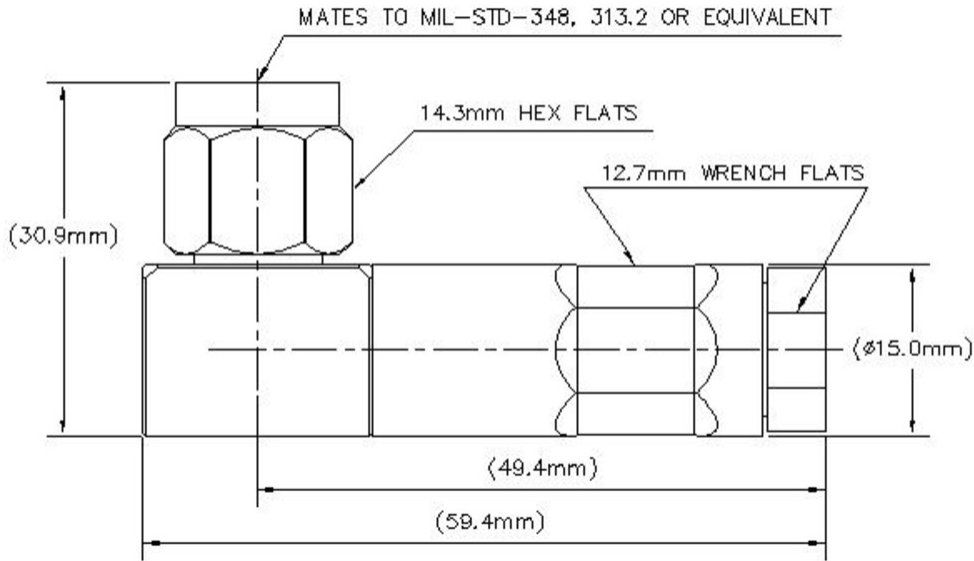

Electrical Specifications

3rd Order IMD at Frequency	-112 dBm @ 910 MHz
3rd Order IMD Test Method	Two +43 dBm carriers
Average Power at Frequency	0.6 kW @ 900 MHz
Cable Impedance	50 ohm
Connector Impedance	50 ohm
dc Test Voltage	1500 V
Inner Contact Resistance, maximum	1.5 mOhm
Insulation Resistance, minimum	5000 MOhm
Operating Frequency Band	0 – 6000 MHz
Outer Contact Resistance, maximum	0.4 mOhm
Peak Power, maximum	5 kW
RF Operating Voltage, maximum (vrms)	500 V
Shielding Effectiveness	-110 dB

VSWR/Return Loss

Frequency Band	VSWR	Return Loss (dB)
824–2700 MHz	1.06	32

Mechanical Specifications

L1PTR-C

Connector Retention Tensile Force	449.27 N 101 lbf
Coupling Nut Proof Torque	1.7 N-m 15.046 in lb
Coupling Nut Proof Torque Method	IEC 61169-16:9.3.11
Coupling Nut Retention Force	445 N 100.04 lbf
Coupling Nut Retention Force Method	IEC 61169-16:9.3.11
Insertion Force	66.72 N 15 lbf
Insertion Force Method	IEC 61169-16:9.3.5
Interface Durability	500 cycles
Interface Durability Method	IEC 61169-4:17
Mechanical Shock Test Method	IEC 60068-2-27

Environmental Specifications

Operating Temperature	-55 °C to +85 °C (-67 °F to +185 °F)
Storage Temperature	-65 °C to +125 °C (-85 °F to +257 °F)
Attenuation, Ambient Temperature	20 °C 68 °F
Average Power, Ambient Temperature	40 °C 104 °F
Average Power, Inner Conductor Temperature	100 °C 212 °F
Corrosion Test Method	IEC 60068-2-11
Immersion Depth	1 m
Immersion Test Mating	Mated
Immersion Test Method	IEC 60529:2001, IP68
Moisture Resistance Test Method	IEC 60068-2-3
Thermal Shock Test Method	IEC 60068-2-14
Vibration Test Method	IEC 60068-2-6

Packaging and Weights

Weight, net	70.7 g 0.156 lb
--------------------	-------------------

Regulatory Compliance/Certifications

Agency	Classification
ISO 9001:2015	Designed, manufactured and/or distributed under this quality management system



L1PTR-C

* Footnotes

Immersion Depth Immersion at specified depth for 24 hours