

M-980 General Purpose Call Progress Tone Detector

The Teltone[®] M-980 is an integrated circuit tone detector for general purpose use in automatic following of switched telephone calls. The circuit uses low-power CMOS techniques to provide the complete filtering and control required for this function. The basic timing of the M-980 is designed to permit operation with almost any progress tone system.

The use of integrated circuit techniques allows the M-980 to pack the complete frequency and amplitude portion of call progress following into a single 8-pin DIP. A 3.58 MHz crystal-controlled time base guarantees accuracy and repeatability.

Features

- Covers the 315 to 640 Hz range (common call progress)
- Sensitivity to -38 dBm
- Dynamic range over 36 dB
- 40 ms minimum detect (50 ms to output)
- 8-pin DIP or 16-pin SOIC
- Single supply CMOS (low power)
- Supply range 4.5 to 5.5 VDC
- Inexpensive 3.58-MHz time base

Applications

- Automatic dialers
- Dialing modems
- Traffic measurement equipment
- Test equipment
- Service evaluation
- Billing systems

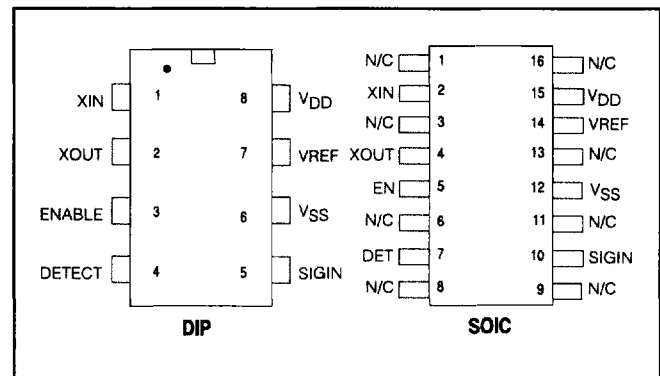

Figure 1 Pin Diagram

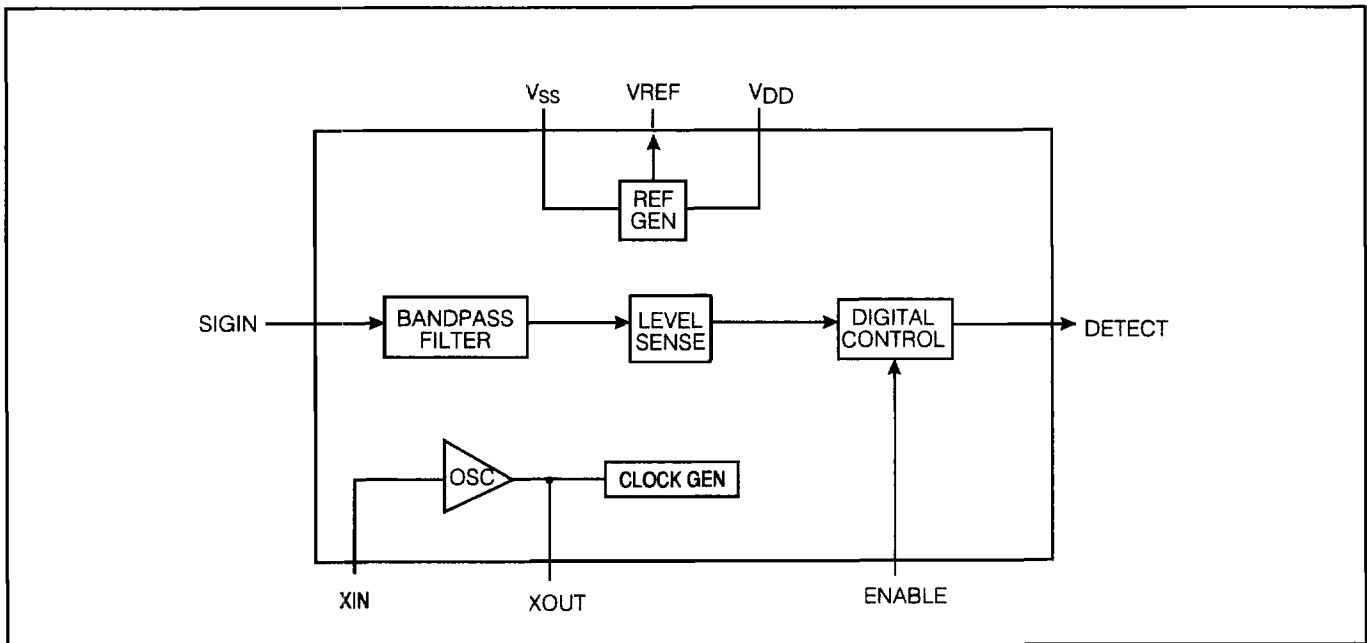

Figure 2 Block Diagram

Table 1 Pin Descriptions

PIN	DESCRIPTION
SIGIN	Signal input, AC or DC coupled (see level limitations elsewhere).
DETECT	Active output indicating signal detection. Activated by ENABLE.
ENABLE	Enables DETECT output. Used to mask signal activity.
V _{DD}	Most positive power supply pin.
V _{REF}	Internally generated reference voltage. (V _{SS} + V _{DD}) / 2 volts.
V _{SS}	Most negative power supply pin.
XIN, XOUT	Crystal attachment pins. XIN may be used as the input for an external 3.58 MHz clock.

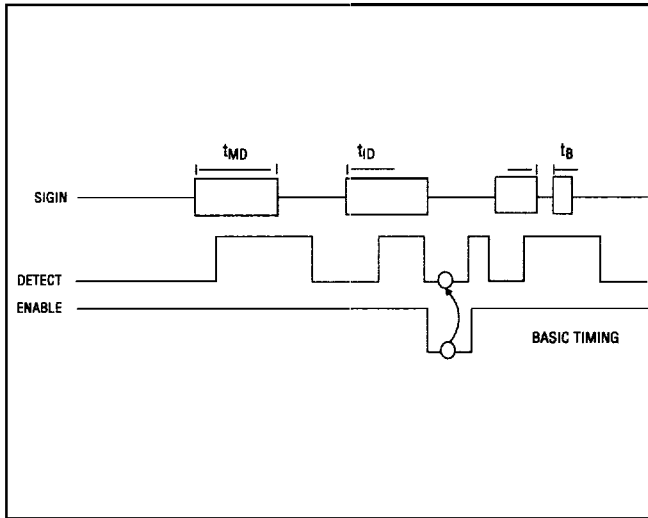

Figure 3 Signal Timing (See Table 2)

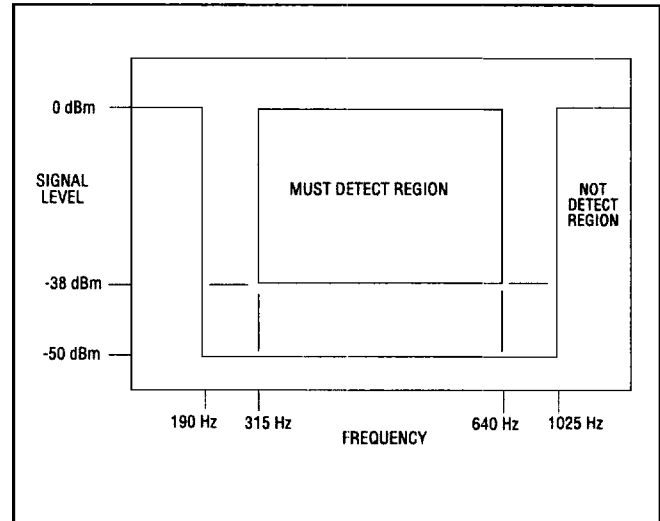

Figure 4 Detect Range

Table 2 Device Timing

TIME	VALUE	SIGNIFICANCE
t _{MD}	40 ms	A valid tone will always be detected if it is at least 40 ms long.
t _{ID}	40 ms @ -38 dBm	Inter-tone gaps must be detected if greater than this duration.
	50 ms @ -10 dBm	
t _B	20 ms	Drop-outs of valid tone of up to 20 ms will be ignored.

Note: Application or removal of high level signals outside the must detect range may cause momentary detection, which may be filtered by time guarding the output.

Table 3 Absolute Maximum Ratings*

DC Supply Voltage (V _{DD} - V _{SS})	16.0V
Voltage on SIGNAL IN	(V _{DD} + 0.5) to (V _{DD} -18V)
Voltage on Any Pin Except SIGNAL IN	(V _{DD} + 0.5V) to (V _{SS} - 0.5V)
Storage Temperature Range	-65° to 150°C
Operating Temperature Range	-30° to 70°C
Lead Soldering Temperature	260°C for 5 seconds

* **Note:** Exceeding these ratings may permanently damage the M-980.

Table 4 Specifications

Unless otherwise noted, $V_{DD} - V_{SS} = 4.5$ to 5.5 V and $T_a = 25$ °C						
PARAMETER		MIN	TYP	MAX	UNITS	NOTES
Supply Current			4	10	mA	
Signal Detection	Level	-38		0	dBm	1,2,9
	Duration	40			ms	
Signal Rejection	Level			-50	dBm	1,2
	Duration			0	dBm	1,3
Quiet Interval Detect	Duration	40			ms	4
		50			ms	5
"Detect" Output Pin	Logic 0			0.5	V	6
	Logic 1	4.5			V	6
"Enable", "XIN" Input Pin	Logic 0	V_{SS}		$V_{SS} + 0.2$	V	7
	Logic 1	$V_{DD} - 0.2$		V_{DD}	V	7
"XIN" Duty Cycle		40		60	%	
"XIN", "XOUT" Loading				10	pF	
"VREF" Output Pin	Deviation	-2		+2	%	8
	Resistance	3.25		6.75	Kohms	
"SIGIN" Input Pin	Max Voltage	$V_{DD} - 18$		V_{DD}	V	
	Impedance (500 Hz)	80			Kohms	

Notes:

- 0 dBm = 0.775 Vrms.
- $f = 315$ to 640 Hz.
- $f > 1025$ Hz, < 190 Hz.
- Signal dropping from -38 to -50 dBm.
- Signal dropping from -10 to -50 dBm.
- Output current = 1 mA, $V_{SS} - V_{DD} = 5.0$ V.
- Input current = 10 μ A max.
- Nominal = $(V_{DD} + V_{SS})/2$.
- -37 dBm ($T_a = 50$ °C), -36 dBm ($T_a = 60$ °C), -35 dBm ($T_a = 70$ °C)

Call Progress Tone Detection

Call progress tones are audible tones sent from switching systems to calling parties to show the status of calls. Calling parties can identify the success of a call placed by what is heard after dialing. The type of tone used and its timing vary from system to system, and though intended for human ears these signals can provide valuable information for automated calling systems.

The Teltone M-980 is a signal detector sensitive to the frequencies most often used for these progress tones. Electronic equipment monitoring the DETECT output of the M-980 can determine the nature of signals present by measuring their duty cycle. See Figure 5 for a diagram of a circuit that could be used to permit a microcomputer to directly monitor tones on the telephone line. Much of the character of the progress tones is in their duty cycle or cadence (sometimes referred to as interruption rate). This information, coupled with level and frequency indication from the M-980, can be used to decide what progress tones have been encountered.

For example, dial tones as shown in the table are usually "on" continuously and last until the first dial digit is received by the switching system. Line Busy, on the other hand, is turned

off and on at a rate of 1 Hz with a 50% duty cycle, or an interruption rate of 60 times per minute (60 IPM). The tones can be distinguished in this way. Table 5 shows some call progress tones with on/off times —0.25/0.25 being 250 ms on, 250 ms off on a repeating basis. It should be noted that while such techniques will usually be effective, there are some circumstances in which the M-980 cannot be accurately used. Examples include situations where ringback tone may be short or not even encountered. Ringback may be provided at ringing voltage frequency (20 or 30 Hz) with some harmonics and may not fall in the detect range, and speech or other strong noise may obscure tones making cadence measurement difficult. Detection of "answer" is most difficult for many reasons. One way to determine if a called party has answered is by looking for a short burst of DETECT indications without a cadence match (produced by a click and "hello" at the far end). Some applications will require special methods like speech detection, but most can be reliably handled with the M-980 and simple cadence measurement.

As can be seen, the tones used for the same purposes in different systems may not be the same. Standards do exist and should be consulted for your particular application. In North America AT&T's "Notes on the Network" or EIA's RS-464 PBX standard should be reviewed. In Europe tone plans may

vary with locale, in which case the CEPT administration in each country must be consulted. Outside these areas, national

PTT organizations can provide information on the systems within their borders.

Table 5 Call Progress Tones

FREQUENCY 1	FREQUENCY 2	ON/OFF	USE
350	+440	Continuous	Dial tones
425	—		
600	X 120		
400	—		
480	+620	0.5/0.5s	Line Busy Tones
600	X 120		
480	+620	0.25/0.25s	Reorder Tones
600	X 120		
440	+ 480	2.0/4.0s	Audible Ringing
500	X 40		
440	—	0.5s burst	Various

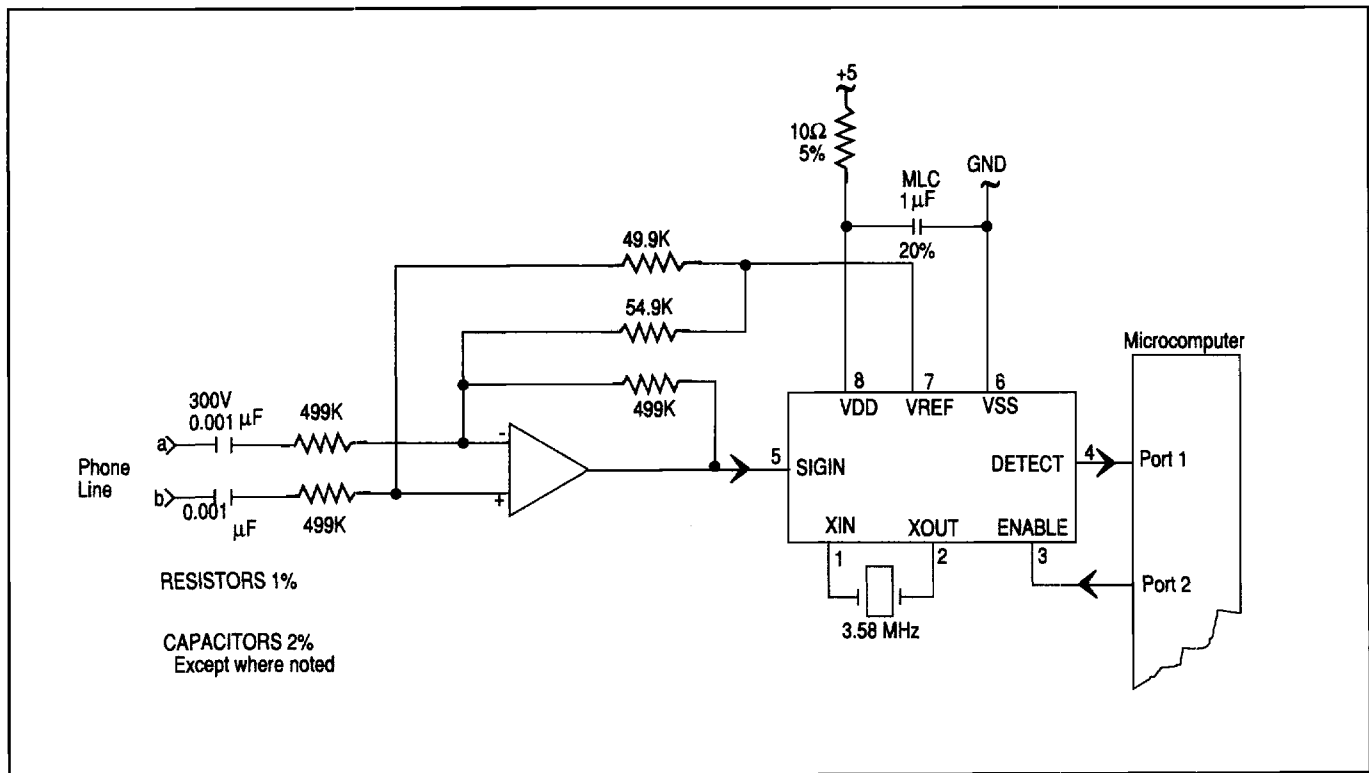

Figure 5 A Telephone Line Circuit Application

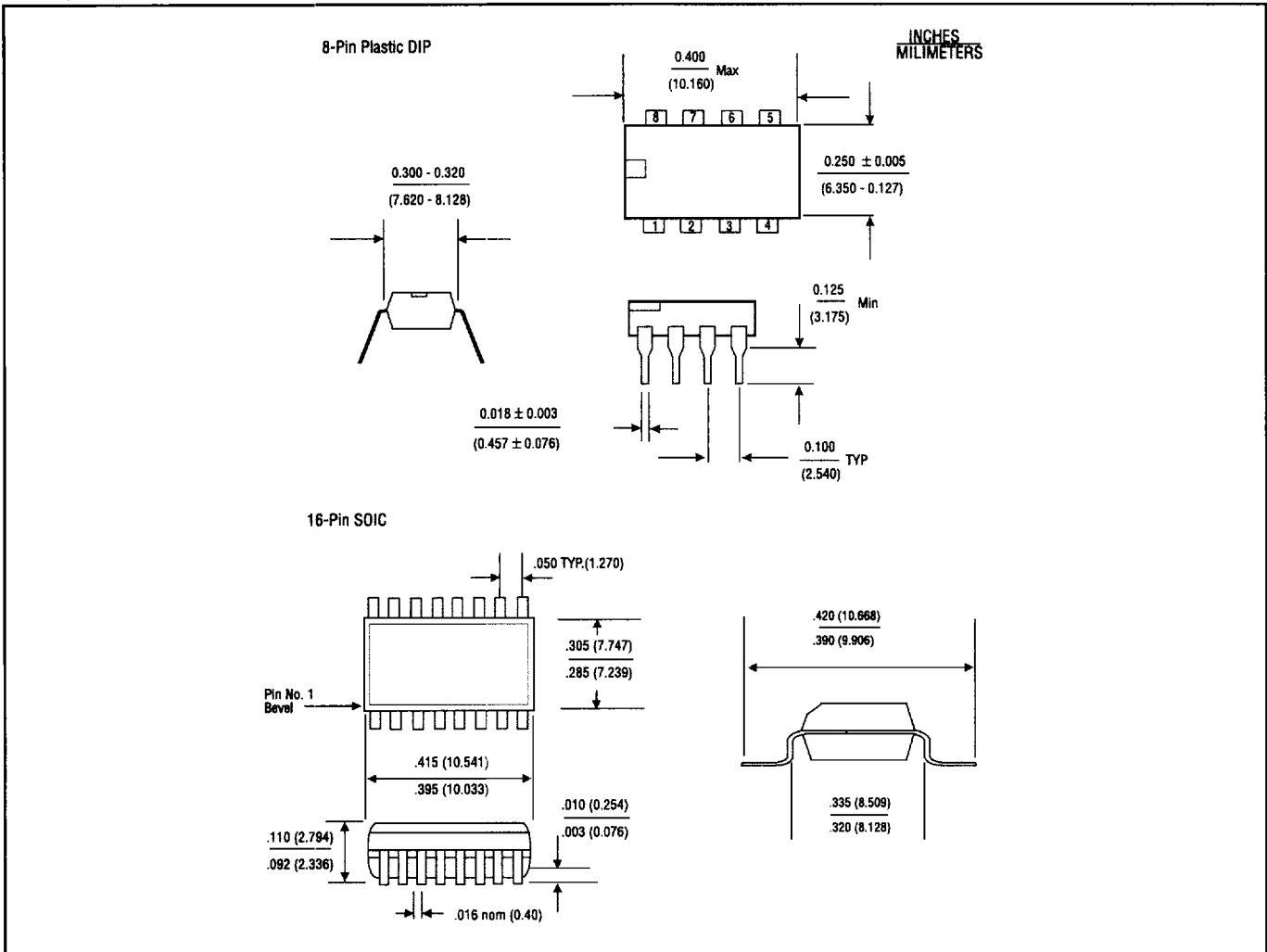

Figure 6 Package Dimensions

Ordering Information

M-980-01P	8-pin plastic DIP
(Formerly M-980)	
M-980-01S	16-pin SOIC
M-980-01T	16-pin SOIC, Tape and Reel