

# Speakerphone Audio Circuit

## GENERAL DESCRIPTION

The XR-T6420-2 is a monolithic integrated circuit for use in high performance speakerphone systems. It is designed to be used with the XR-T6421 Speakerphone Control Circuit.

The XR-T6420-2 contains the audio paths comprising the following. Two variable gain cells, a microphone amplifier, a transmitting amplifier, a receive amplifier, and a speaker amplifier. Mute and enable control logic of the variable gains cells is provided internally.

## FEATURES

- Two Matched Variable Gain Cells
- Internal Microphone Amplifier
- Independent Control of Transmitting and Receiving Levels
- External Control of Gains and Frequency Response
- Enable and Mute Logic Pins

## APPLICATIONS

- Speakerphones
- Intercoms
- Voltage Controlled Amplifiers

## ABSOLUTE MAXIMUM RATINGS

Power Supply ( $V_{CC} - V_{EE}$ )	+30 V
Power Dissipation	1 W
Derate Above +25°C	7 mW/°C
Any Input Voltage	$V_{CC} - 0.5 \text{ V to } V_{EE} + 0.5 \text{ V}$
Storage Temperature	-65°C to +150°C

## ORDERING INFORMATION

Part Number	Package	Operating Temperature
XR-T6420-2CJ	PLCC	0°C to 70°C
XR-T6420-2CP	Plastic	0°C to 70°C

## FUNCTIONAL BLOCK DIAGRAM

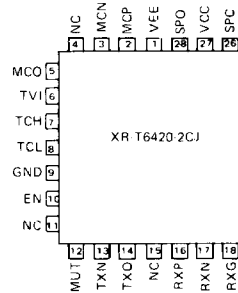
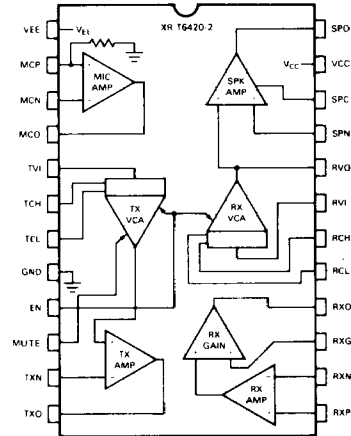

## SYSTEM DESCRIPTION

The speakerphone concept essentially requires that only one direction of sound transmission be permitted at any time. This restraint is brought about by the large gains required to provide loudspeaker volume and high microphone sensitivity. Owing to the inevitable acoustic coupling between loudspeaker and microphone, plus imperfections in the hybrid 2 to 4 wire conversion, it is necessary to lower the gain in either the transmitting or receiving path at any one time to avoid regeneration.

The XR-T6420-2 and XR-T6421 chip set enables the system designer to make a highly adaptive, high performance speakerphone. The XR-T6421 provides for all sensing and control functions, while the XR-T6420-2 contains all audio paths needed to switch the gain in either path and provide interfacing between the system and line.

# XR-T6420-2

## ELECTRICAL CHARACTERISTICS

Test Conditions:  $T_A = 25^\circ\text{C}$ ,  $V_{CC} = +5\text{ V}$ ,  $V_{EE} = -5\text{ V}$ , unless specified otherwise.

PARAMETERS	MIN.	TYP.	MAX.	UNIT	CONDITIONS
$V_{CC}$ $V_{EE}$ $I_{CC}$	3 3	4.9	8	V V mA	Pin 23
MICROPHONE AMPLIFIER					
$V_{IN}$ $R_{IN}$ $V_{OFFSET}$ $I_{BIAS}$ Open Loop Gain	80	5 20 -2	25 5 -0.5	mV k $\Omega$ mV $\mu\text{A}$ dB	Pin 2 Pin 2
SPEAKER AMPLIFIER					
$R_{IN}$ $V_{OFFSET}$ $I_{BIAS}$ Open Loop Gain $I_{SOURCE}$ , $I_{SINK}$ $V_{OUT}$ High $V_{OUT}$ Low	80 100 $V_{CC}$ -1.6 $V_{EE}$ +8	10 -2	5 -0.5	k $\Omega$ mV $\mu\text{A}$ dB mA V V	Pin 20   $R_{LOAD} = 10\Omega$ $R_{LOAD} = 5k\Omega$ $R_{LOAD} = 5k\Omega$
TRANSMIT AMPLIFIER					
$I_{BIAS}$ Open Loop Gain		-2 90	-0.5	$\mu\text{A}$ dB	
RECEIVE AMPLIFIER					
$I_{BIAS}$ Differential Mode Gain Common Mode Gain $I_{BIAS}$ Open Loop Gain	-3 -40	1.2 -1 -60 -2 90	2 -5	$\mu\text{A}$ dB dB $\mu\text{A}$ dB	Pin 13, Pin 14 Pins 15 and 16 Shorted Pins 15 and 16 Shorted Pin 15
VCAs TRANSMIT AND RECEIVE					
$V_{OUT}$ DC Maximum Gain $I_{BIAS}$ Control	-2		.3 +2 .5	V dB $\mu\text{A}$	Pins 11 and 20 $f = 1\text{ kHz}$ , Pins 5 and 19 Pins 6, 7, 17 and 18
MUTE AND ENABLE LOGIC					
$I_{SOURCE}$ Trip Voltage		-10 $V_{CC}$ -2.8	-20 $V_{CC}$ -2.1	$\mu\text{A}$ V	

## PRINCIPLES OF OPERATION

### Power Supply

Normal operation is with two supplies.  $V_{CC}$  is the highest potential and  $V_{EE}$  is the lowest. The circuit can be operated from a single supply if the ground pin is connected to a low impedance source of approximately one half the supply voltage.

### Microphone Amplifier

The microphone amplifier is an operational amplifier with the positive input internally connected to the ground pin through a 20 K ohm nominal resistance. Gain and frequency responses are set using external components.

### Transmit Voltage Controlled Amplifier ( $T_X$ VCA)

The output of the microphone amplifier is normally capacitively coupled into the  $T_X$  VCA. The input impedance is nominally 10 K ohm. The gain of the  $T_X$  VCA is dependent upon the voltage difference between the TCH and TCL inputs on pins 6 and 7. The output is internally connected to the transmit amplifier.

### Transmit Amplifier

This is an operational amplifier with a class AB output stage. Gain and frequency response are set with external components. This amplifier is used to drive the hybrid interface network.

### Receive Amplifier

The input on pins 13 and 14 is a high input impedance differencing amplifier. The output is internally referenced to the ground pin and connected to the positive input of an operational amplifier. The gain and frequency response of the amplifier can be adjusted using external components on pins 15 and 16. This amplifier is normally connected to the hybrid interface network to detect the receive signal while rejecting the transmit signal.

### Receive Voltage Controlled Attenuator ( $R_X$ VCA)

The output of the receive amplifier is capacitively coupled to the  $R_X$  VCA input on pin 19. The  $R_X$  VCA's input impedance is a nominal 10 K ohm. The gain of the  $R_X$  VCA is dependent upon the voltage difference between the RCH and RCL inputs on pins 17 and 18. The output of the  $R_X$  VCA is internally referenced to the ground pin through a 10 K ohm resistance and connected to the positive input of the speaker amplifier on pin 20.

### Speaker Amplifier

This is an operational amplifier with a class AB power output stage. Gain and frequency response are set using external components. Depending on the load driven, compensation may be necessary using pin 22.

## PIN DESCRIPTIONS

**Pin 1 -  $V_{EE}$**  — Negative DC supply.

**Pin 2 - MCP** — Microphone amplifier noninverting input. Internally connected to ground with a 20 K ohm resistance.

**Pin 3 - MCN** — Microphone amplifier inverting input.

**Pin 4 - MCO** — Microphone amplifier output.

**Pin 5 - TVI** — Transmit voltage controlled amplifier input. Input impedance is 10 K ohm.

**Pin 6 - TCH** — Transmit VCA gain control pin; high reference. Used with pin 7 to control VCA gain according to Figure 1.

**Pin 7 - TCL** — Transmit VCA gain control pin; low reference. Used with pin 6 to control VCA gain.

**Pin 8 - GND** — Ground reference pin for circuit.

**Pin 9 - ENABLE** — Active high; internally pulled high. When pulled low, causes an internal 200 mV difference between the gain control pins for both VCAs effectively causing minimum gain in both.

**Pin 10 - MUTE** — Internally pulled high. When pulled low, causes only the transmit VCA to be minimum gain.

**Pin 11 -  $T_XN$**  — Transmit amplifier inverting input.

**Pin 12 -  $T_XO$**  — Transmit amplifier output.

**Pin 13 -  $R_XP$**  — Receive amplifier positive input. High input impedance, must be DC referenced externally.

**Pin 14 -  $R_XN$**  — Receive amplifier negative input. Must be DC referenced to same source as pin 13.

**Pin 15 -  $R_XG$**  — Receive amplifier inverting input.

**Pin 16 -  $R_XO$**  — Receive amplifier op amp output.

# XR-T6420-2

**Pin 17 - RCL** – Receive VCA gain control pin low referenced used with pin 18 to control VCA gain according to Figure 1.

**Pin 18 - RCH** – Receive VCA gain control pin; high reference used with pin 17 to control gain of VCA.

**Pin 19 - RVt** – Receive VCA input. Input impedance is 10 K ohm.

**Pin 20 - RVO** – Receive VCA output. Impedance is 10 Kohm to ground.

**Pin 21 - SPN** – Speaker amplifier inverting input.

**Pin 22 - SPC** – Speaker amplifier compensation.

**Pin 23 - VCC** – Positive DC supply.

**Pin 24 - SPO** – Speaker amplifier output.

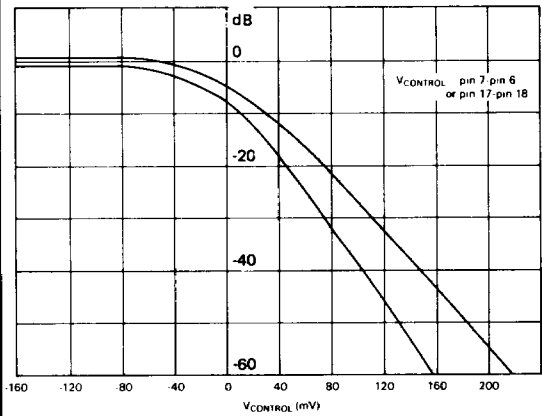

Figure 1. VCA Gain Characteristics

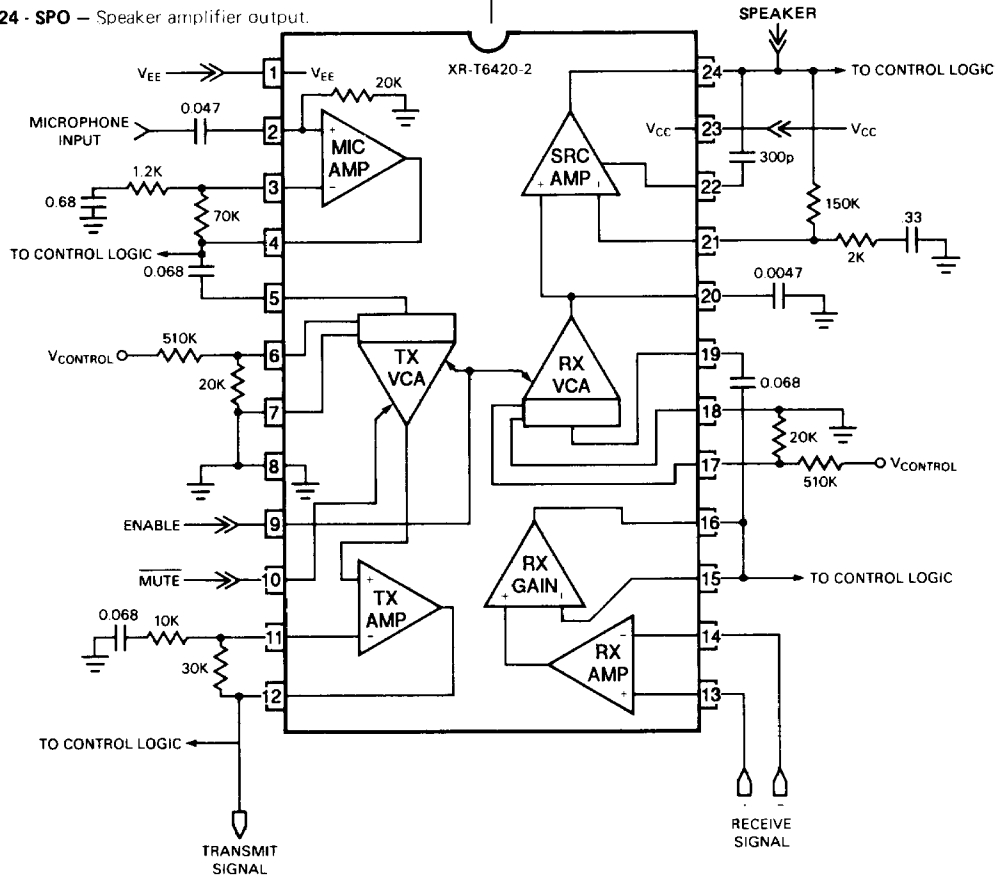

Figure 2. Typical Application Schematic