

# SPECIFICATION CONTROL DRAWING

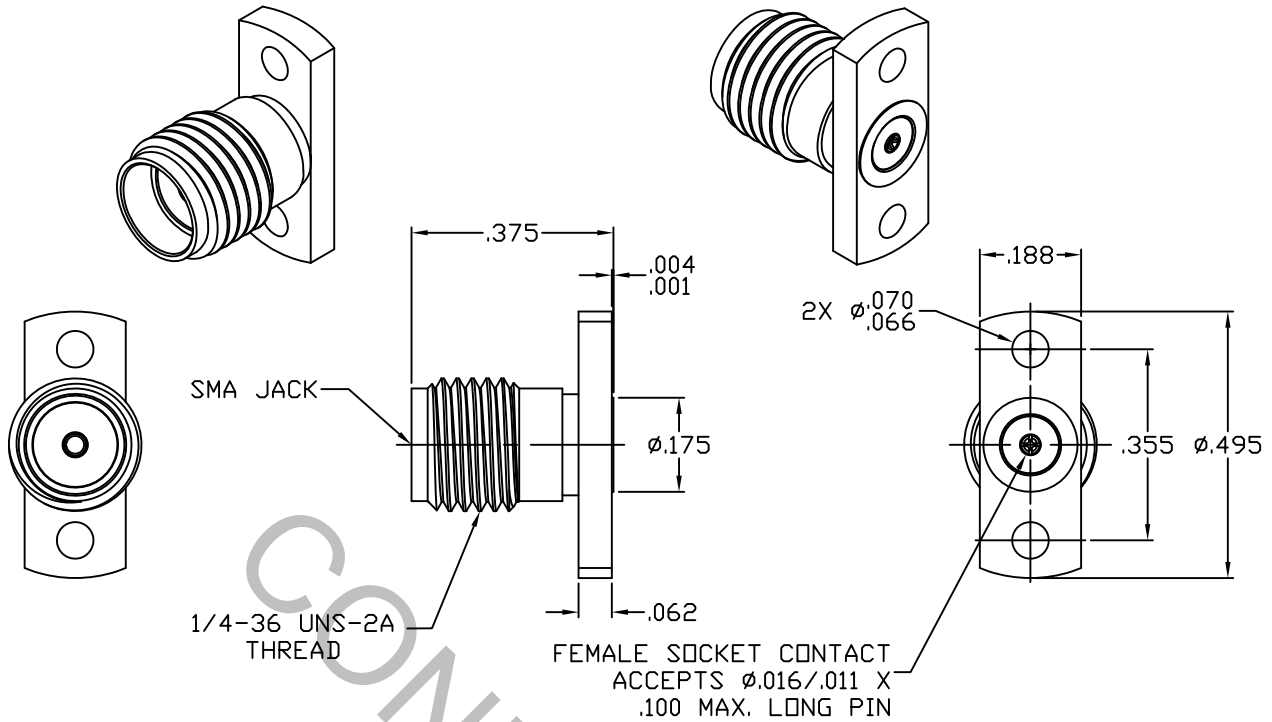

1. MATING INTERFACE DIMENSIONS FOR SMA JACK per MIL-STD-348 (Fig. 310-2).

## 2. ELECTRICAL

FREQUENCY RANGE GHz	_____	DC TO 26.5 GHz
VSWR (MAX.) *	_____	1.05 + .006 x FGHz
INSERTION LOSS (dB MAX.) *	_____	.03 dB x $\sqrt{\text{FGHz}}$
NOMINAL IMPEDANCE (OHMS)	_____	50
VOLTAGE RATING (MAX. VRMS)	_____	250
RF LEAKAGE (MIN. dB DOWN)	_____	100 dB - FGHz
TEMPERATURE RATING (DEGREES CENTIGRADE)	_____	-65 °C TO + 165 °C
DIELECTRIC WITHSTANDING VOLTAGE (MAX. VRMS)	_____	750
INSULATION RESISTANCE (MIN. MEGOHMS)	_____	5,000
CONTACT RESISTANCE		
• CENTER CONTACT (MAX. MILLIOHMS)	_____	6.0
• OUTER CONTACT (MAX. MILLIOHMS)	_____	2.0

\* TERMINATED IN A 50 OHM LOAD

**RoHS**  
COMPLIANT

This Document contains proprietary and confidential information.

REV.	DCN NO.	DATE	APP.	DIMENSIONS ARE IN INCHES TOLERANCES			 <small>INCORPORATED</small> HAVERHILL, MA. 01835
				DECIMALS	FRACTIONAL	ANGULAR	
—	875	7/92	CT	$\pm$ .030		$\pm$ 1 °	
AA	08-1667	7/23/08	DC	$\pm$ .010	$\pm$ 1/64	$\pm$ 15'	
AB	17-1879	7/19/17	DC	$\pm$ .005			
				DRAWN	CT	DATE	7/92
				APPROVED	DGG	DATE	7/92
				CODE IDENT.			
				2J899		SHEET 1 OF 2	
						DWG. NO.	9952-0881-6213
							TITLE SMA, JACK 2 HOLE FLANGE FIELD REPLACEABLE

# SPECIFICATION CONTROL DRAWING

## 3. MECHANICAL

### CAPTIVATION-CENTER CONTACT

MAX. AXIAL FORCE \_\_\_\_\_ 6.0 LBS.

MAX. RADIAL TORQUE \_\_\_\_\_ N/A

### CENTER CONTACT AXIAL FORCES

● INSERTION (MAX. OUNCES) \_\_\_\_\_ INTERFACE 48.0, REAR 32.0

● WITHDRAWAL (MIN. OUNCES) \_\_\_\_\_ INTERFACE 2.0, REAR 1.0

CONNECTOR DURABILITY (MIN. CYCLES) \_\_\_\_\_ 500

## 4. ENVIRONMENTAL

TEMPERATURE CYCLING \_\_\_\_\_ MIL-STD-202, METHOD 102, COND. C ( -65°c TO + 165°c )

SHOCK \_\_\_\_\_ MIL-STD-202, METHOD 213, COND. I (100 G's)

VIBRATION \_\_\_\_\_ MIL-STD-202, METHOD 204, COND. D (20 G's)

MOISTURE RESISTANCE \_\_\_\_\_ MIL-STD-202, METHOD 106, LESS STEP 7b

CORROSION \_\_\_\_\_ MIL-STD-202, METHOD 101, COND. B (48 HOURS)

BAROMETRIC PRESSURE (ALTITUDE) \_\_\_\_\_ MIL-STD-202, METHOD 105, COND. C ( 70,000 FT. ) ( 190 VRMS )

## 5. MATERIAL

BODY \_\_\_\_\_ STAINLESS STEEL PER ASTM A 582, TYPE 303, COND. A

CONTACT \_\_\_\_\_ BERYLLIUM COPPER PER ASTM B196/B 196M-03, COPPER ALLOY  
UNS C17300, TEMPER TD04

INSULATOR \_\_\_\_\_ TEFLON PER ASTM-D-1710, TYPE 1, CLASS B

## 6. FINISH

BODY \_\_\_\_\_ PASSIVATE PER AMS-2700, TYPE 2, CLASS 4

CONTACT \_\_\_\_\_ GOLD PER ASTM B 488, TYPE 1, CODE C, CLASS 1.27  
(.000050 MIN. THK.) OVER NICKEL PER SAE-AMS-QQ-N-290  
CLASS 1 (.000050 MIN. THK.) OVER COPPER PER AMS-2418  
(.000010 MIN. THK.)

INSULATOR \_\_\_\_\_ N/A