

CX65105

1700 - 2200 MHz Linear Power Amplifier

Conexant's CX65105 power amplifier is a fully matched 8-pin Leadless Chip Carrier (LCC) surface mount module, developed for Personal Communication System (PCS) and Wireless Local Loop (WLL) applications. This small, power-efficient amplifier has a full 1700 to 2200 MHz bandwidth coverage packed into a single compact package. All active circuitry in the module is contained in a single Gallium Arsenide (GaAs) Microwave Monolithic Integrated Circuit (MMIC). This device is manufactured with Conexant's Aluminum (Al)GaAs Heterojunction Bipolar Transistor (HBT) process, which allows for single supply operation while maintaining high efficiency and good linearity.

Figure 1 shows a functional block diagram for the CX65105. The device package and pinout are shown in Figure 2.

Distinguishing Features

- Typical P_{OUT} of 27 dBm
- High linearity
- Low power consumption
- 8-pin LCC package
- Single +5 V supply

Applications

- PCS/DCS/UMTS
- Repeaters
- WLL, and Industrial, Scientific, Medical (ISM) bands
- Mobile radio
- Telematics

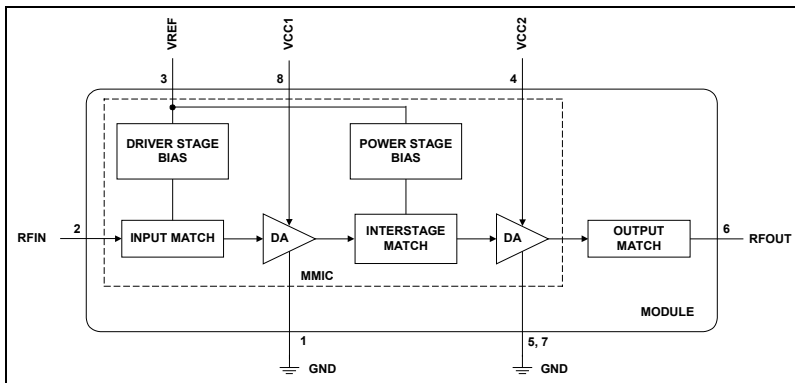

Figure 1. CX65105 Functional Block Diagram

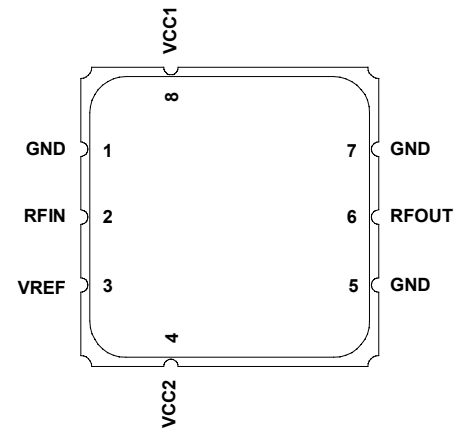

Figure 2. CX65105 Pinout – 8-Pin LCC Package Top View

Electrical and Mechanical Specifications

The signal pin assignments and functions are described in Table 1. The absolute maximum ratings of the CX65105 are provided in Table 2. The recommended operating conditions are specified in Table 3 and electrical specifications are provided in Table 4.

Typical performance characteristics over temperature of the CX65105 are illustrated in Figures 3, 4, 5, 6, 7, and 8.

Table 1. CX65105 Signal Descriptions

Pin #	Name	Description
1	GND	Ground
2	RFIN	RF input
3	VREF	Reference voltage
4	VCC2	Supply voltage
5	GND	Ground
6	RFOUT	RF output
7	GND	Ground
8	VCC1	Supply voltage

Table 2. CX65105 Absolute Maximum Ratings

Parameter	Symbol	Min	Typical	Max	Units
RF input power	PIN			7	dBm
Supply voltage	VCC			8.5	V
Reference voltage	VREF			4	
Case operating temperature	Tc	-30		110	°C
Storage temperature	TST	-55		125	°C
Note: No damage to device if only one parameter is applied at a time with other parameters at nominal conditions.					

Table 3. CX65105 Recommended Operating Conditions

Parameter	Symbol	Min	Typical	Max	Units
Supply voltage	VCC		5		V
Reference voltage	VREF		3.6		V
Operating frequency	FO	1700	1900	2200	MHz
Case operating temperature	Tc	-30	25	85	°C

Table 4. CX65105 Electrical Characteristics
 (VCC = 5 V, VREF = 3.6 V, Frequency = 1900 MHz, Tc = 25 °C)

Parameter	Symbol	Test Conditions	Min	Typical	Max	Units
Analog Inputs						
Frequency range			1700	1900	2200	MHz
Quiescent current	Iq			143	185	mA
Small signal gain	G	PIN = -15 dBm	22.5	24.0		dB
Output power	POUT	PIN = 4 dBm	26	27		dBm
Efficiency	PAE	PIN = 4 dBm	20	25		%
Noise Figure (NF)	NF			6	7	dB
Output IP3	OIP3	Two tones with 100 kHz spacing PIN = 0 dBm per tone	36	40		dBm

Note: The above specifications apply only to the 1900 MHz operating frequency.

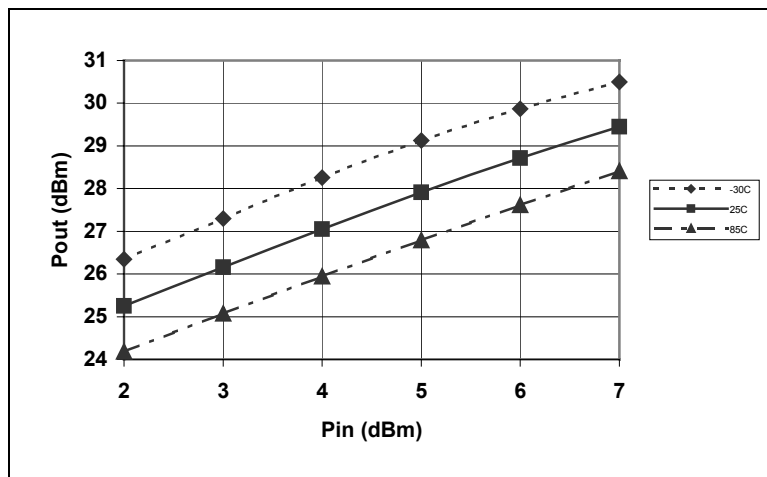

Figure 3. Typical POUT vs PIN Over Temperature

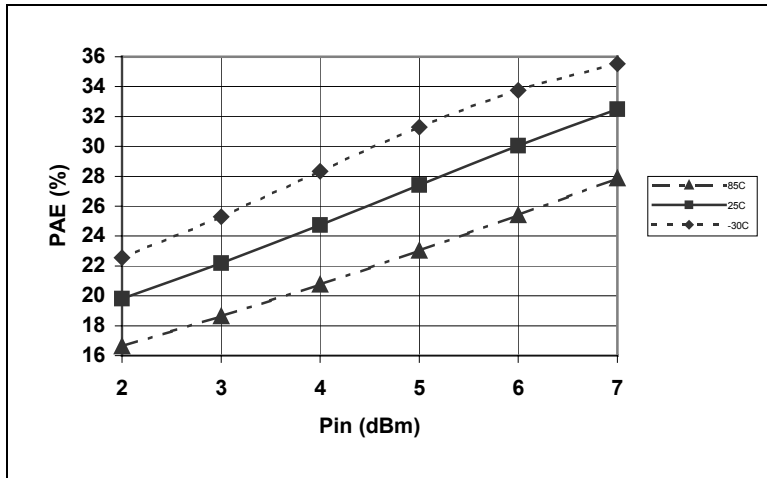

Figure 4. Typical PAE vs Pin Over Temperature

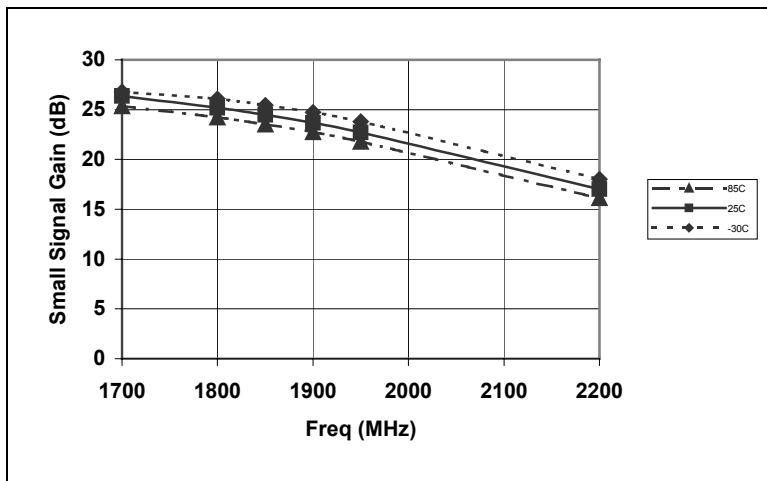

Figure 5. Typical Small Signal Gain vs Frequency Over Temperature

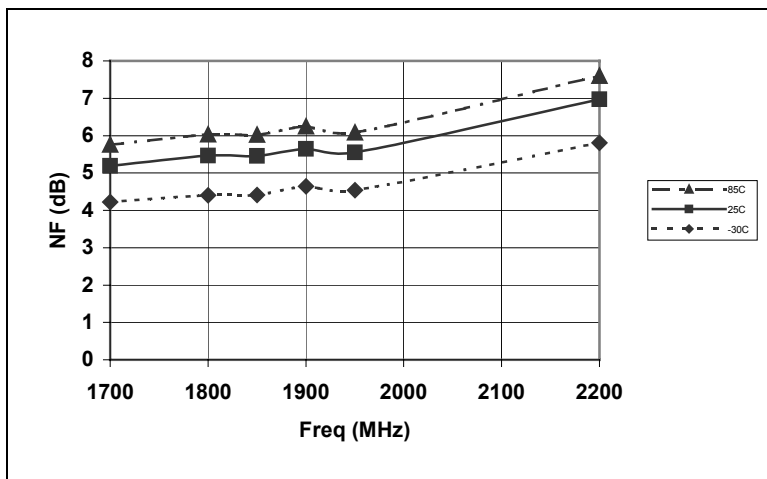

Figure 6. Typical Noise Figure vs Frequency Over Temperature

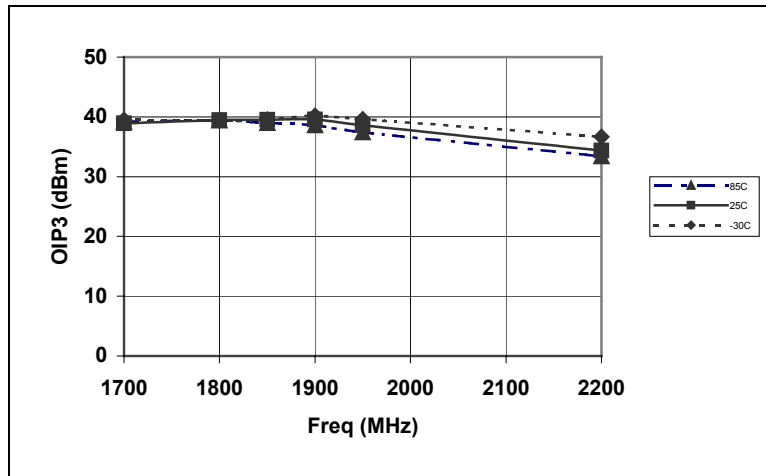

Figure 7. Typical OIP3 vs Frequency Over Temperature

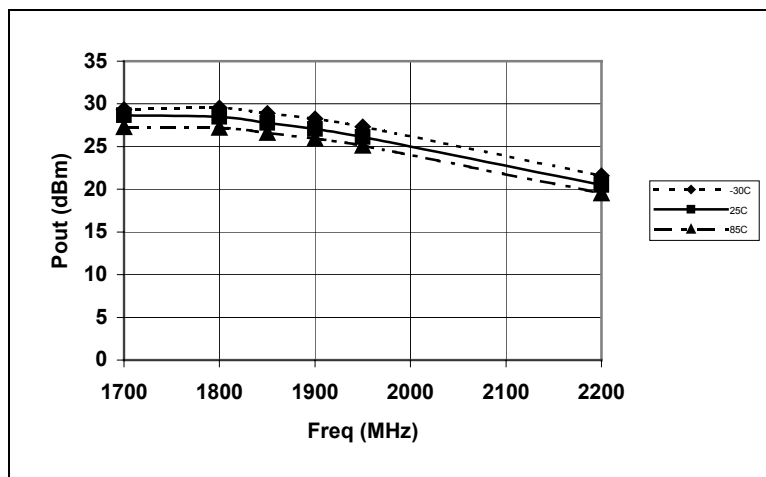

Figure 8. Typical Pout vs Frequency Over Temperature

Evaluation Board Description

Conexant's CX65105 Evaluation Board is used to test the CX65105 power amplifier's performance. The CX65105 Evaluation Board schematic diagram is shown in Figure 9. The schematic shows the basic design of the board for the 1700 to 2200 MHz range. Figure 10 provides the Evaluation Board assembly diagram. Figure 11 provides the Evaluation Board layer detail.

Circuit Design Considerations

The following design considerations are general in nature and must be followed regardless of final use or configuration:

1. Paths to ground should be made as short as possible.
2. The ground pad of the CX65105 power amplifier has special electrical and thermal grounding requirements. This pad is the main thermal conduit for heat dissipation. Since the circuit board acts as the heat sink, it must shunt as much heat as possible from the amplifier. As such, design the connection to the ground pad to dissipate the maximum wattage produced to the circuit board. Multiple vias to the grounding layer are required.
3. Two external output bypass capacitors, 0.01 μF and 4.7 μF , are required on the VCC1 (pin 8) supply input. The same two capacitors are also required on the VCC2 (pin 4) supply input. Both capacitors should be placed in parallel

between the supply line and ground. Also, a bypass capacitor of 0.01 μF is required on the VREF input (pin 3). See Figure 9 for a detailed diagram.

4. VCC1 (pin 8) and VCC2 (pin 4) may be connected together at the supply.
5. At the RF input (pin 2), a DC blocking capacitor is required.
6. The RF output includes an onboard internal DC blocking capacitor. All impedance matching is provided internally. Therefore, the application only needs to provide a good 50 Ω load.

Testing Procedure

Use the following procedure to set up the CX65105 Evaluation Board for testing. Refer to Figure 12 for guidance:

1. Connect a +5.0 V supply voltage to VCC1 and VCC2, and +3.6 V supply voltage to VREF. If available, enable the current limiting function of the power supplies to 1.0 A for the +5.0 V supply current and 30 mA for the +3.6 V supply current.
2. Connect a signal generator to the RF signal input port. Set it to the desired RF frequency at a power level of 4 dBm or less to the Evaluation Board but do NOT enable the RF signal.
3. Connect a spectrum analyzer to the RF signal output port.
4. Enable the power supply.
5. Enable the RF signal.
6. Take measurements.

Caution: *If the input signal exceeds the rated power, the CX65105 Evaluation Board can be permanently damaged.*

Package Dimensions

Figure 13 shows the package dimensions for the 8-pin CX65105 LCC and Figure 14 provides the tape and reel dimensions.

Package and Handling Information

Since the device package is sensitive to moisture absorption, it is baked and vacuum packed before shipping. Instructions on the shipping container label regarding exposure to moisture after the container seal is broken must be followed. Otherwise, problems related to moisture absorption may occur when the part is subjected to high temperature during solder assembly.

If the part is attached in a reflow oven, the temperature ramp rate should not exceed 5 $^{\circ}\text{C}$ per second. Maximum temperature should not exceed 225 $^{\circ}\text{C}$ and the time spent at a temperature that exceeds 210 $^{\circ}\text{C}$ should be limited to less than 10 seconds. If the part is manually attached, precaution should be taken to ensure that the part is not subjected to a temperature that exceeds 300 $^{\circ}\text{C}$ for more than 10 seconds.

Care must be taken when attaching this product, whether it is done manually or in a production solder reflow environment. For additional details on both attachment techniques, precautions, and recommended handling procedures, refer to the Conexant document *Solder Reflow Application Note*, document number 101536.

Production quantities of this product are shipped in a standard tape and reel format. For packaging details, refer to the Conexant document *Tape and Reel Information Application Note*, document number 101568.

Electro-Static Discharge (ESD) Sensitivity

The CX65105 is a static-sensitive electronic device. Do not operate or store near strong electrostatic fields. Take proper ESD precautions.

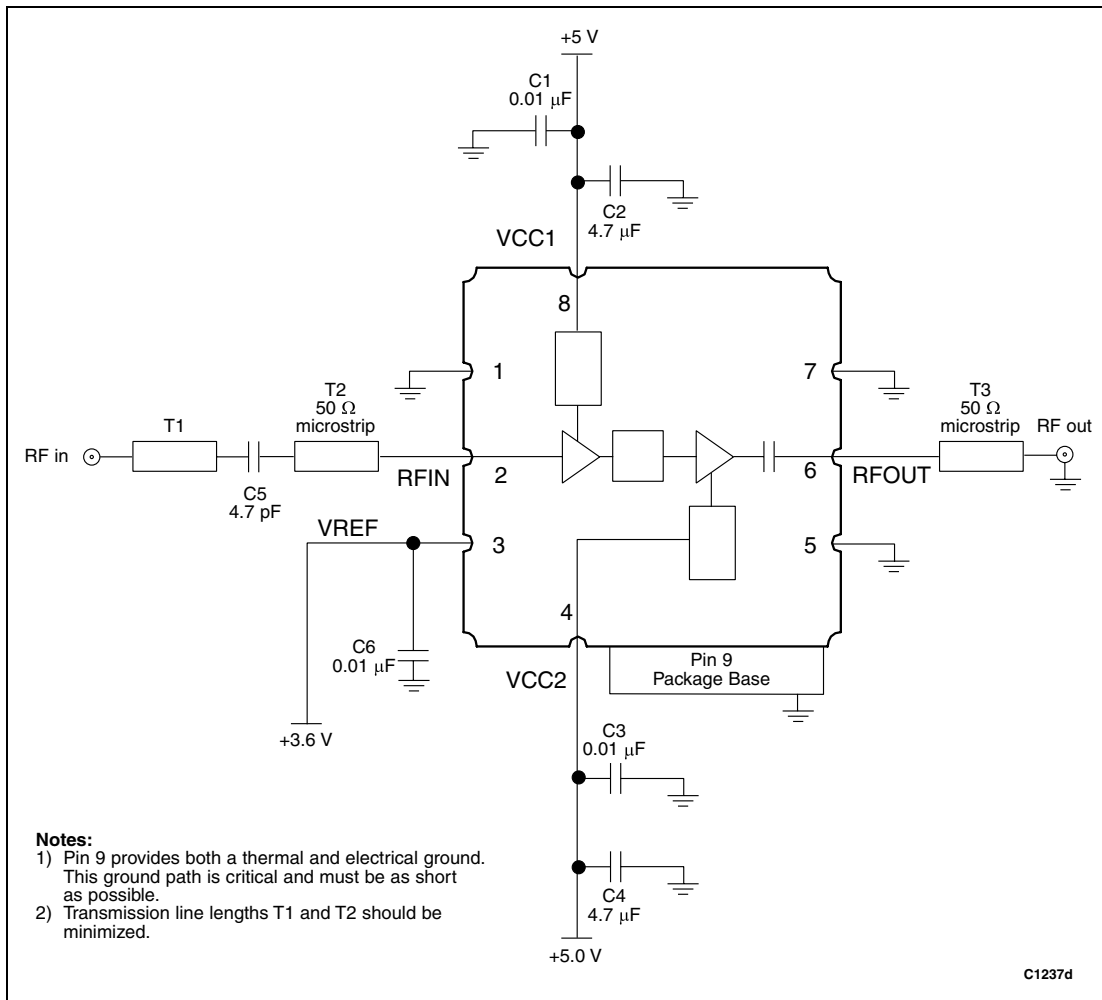

Figure 9. Evaluation Board Schematic, 1700 MHz to 2200 MHz

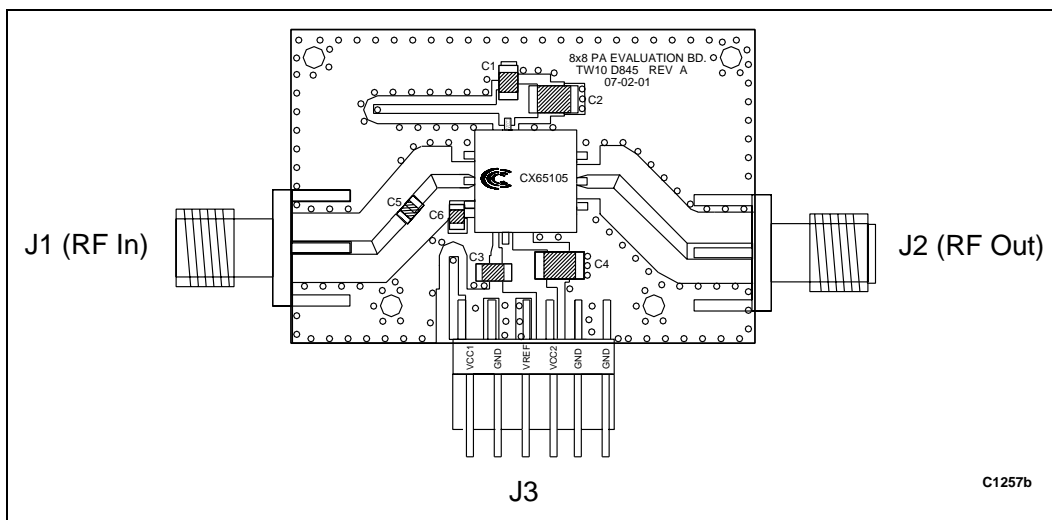
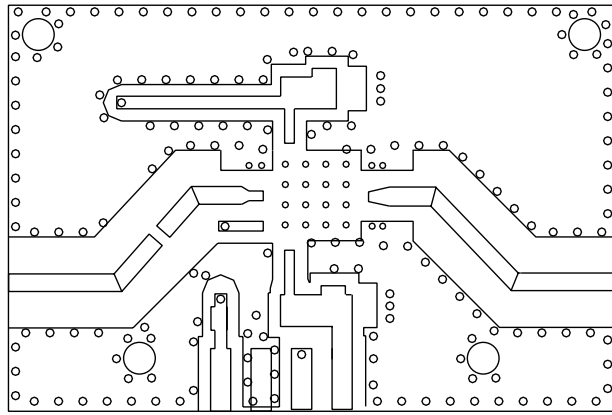
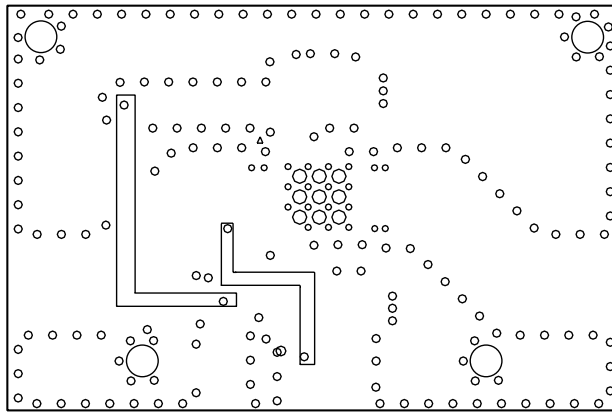

Figure 10. Evaluation Board Assembly Diagram (Top View)



Layer 1: Top - Metal



Layer 2: Inner Traces

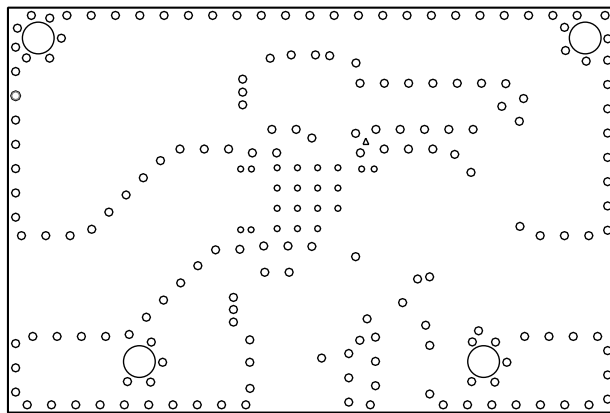

Layer 3: Solid Ground Plane

C1253d

Figure 11. Evaluation Board Layer Detail

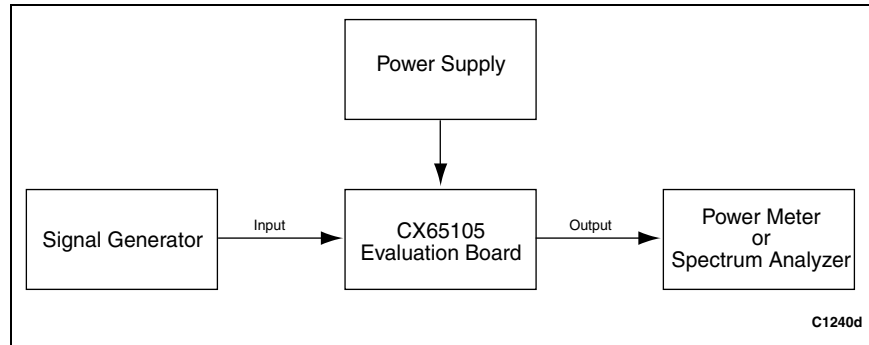

Figure 12. CX65105 Evaluation Board Testing Configuration

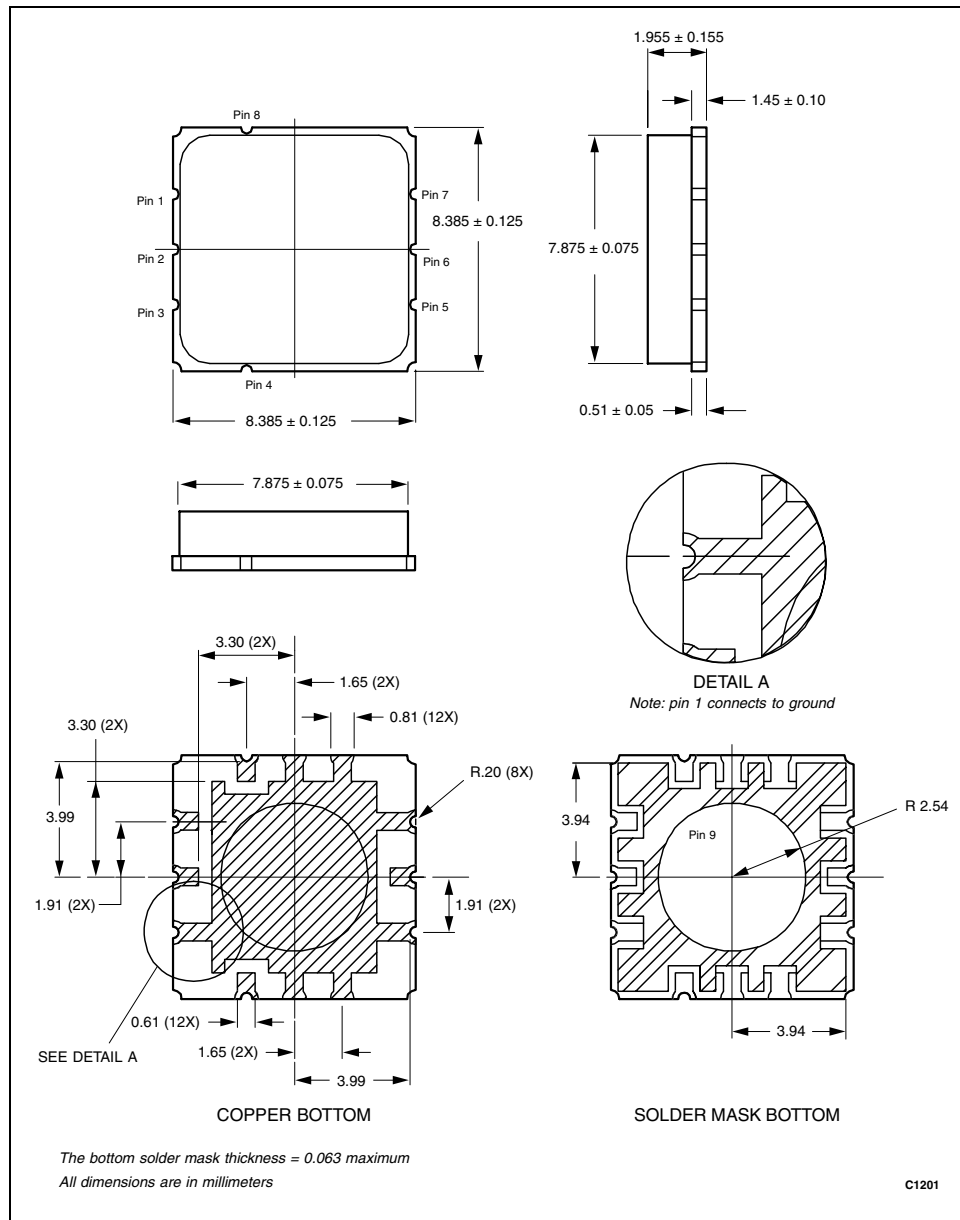

Figure 13. CX65105 8-Pin LCC Package Dimension Drawing

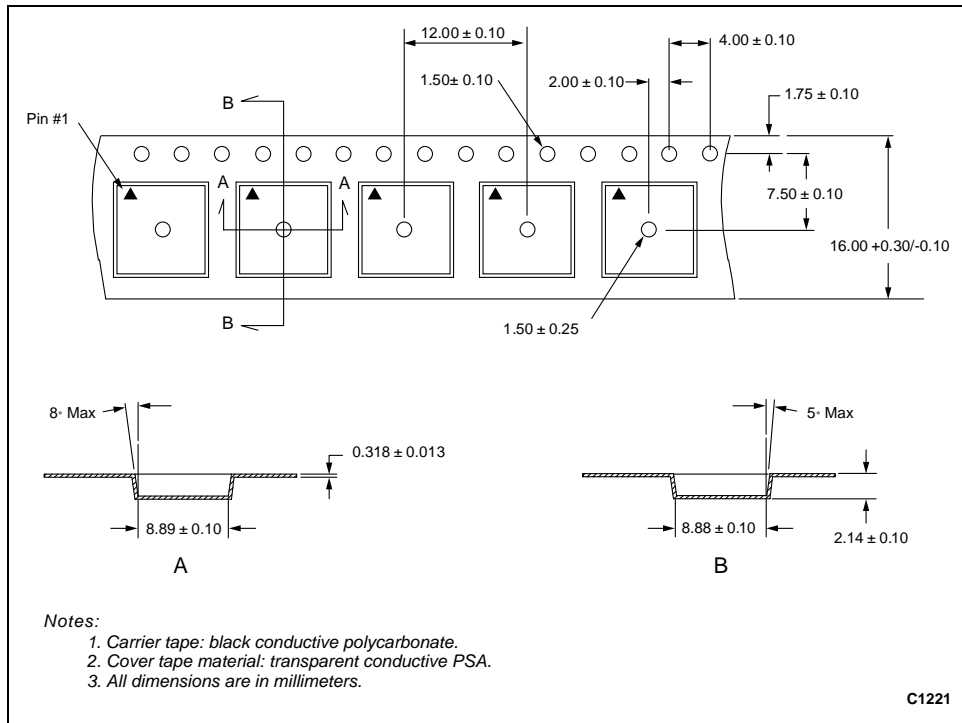

Figure 14. CX65105 8-Pin LCC Tape and Reel Dimensions

Ordering Information

Model Name	Ordering Part Number	Evaluation Kit Part Number
CX65105 1700-2200 MHz Linear Power Amplifier	CX65105-11	TW10-D842

© 2001, 2002, Conexant Systems, Inc. All Rights Reserved.

Information in this document is provided in connection with Conexant Systems, Inc. ("Conexant") products. These materials are provided by Conexant as a service to its customers and may be used for informational purposes only. Conexant assumes no responsibility for errors or omissions in these materials. Conexant may make changes to specifications and product descriptions at any time, without notice. Conexant makes no commitment to update the information and shall have no responsibility whatsoever for conflicts or incompatibilities arising from future changes to its specifications and product descriptions.

No license, express or implied, by estoppel or otherwise, to any intellectual property rights is granted by this document. Except as provided in Conexant's Terms and Conditions of Sale for such products, Conexant assumes no liability whatsoever.

THESE MATERIALS ARE PROVIDED "AS IS" WITHOUT WARRANTY OF ANY KIND, EITHER EXPRESS OR IMPLIED, RELATING TO SALE AND/OR USE OF CONEXANT PRODUCTS INCLUDING LIABILITY OR WARRANTIES RELATING TO FITNESS FOR A PARTICULAR PURPOSE, CONSEQUENTIAL OR INCIDENTAL DAMAGES, MERCHANTABILITY, OR INFRINGEMENT OF ANY PATENT, COPYRIGHT OR OTHER INTELLECTUAL PROPERTY RIGHT. CONEXANT FURTHER DOES NOT WARRANT THE ACCURACY OR COMPLETENESS OF THE INFORMATION, TEXT, GRAPHICS OR OTHER ITEMS CONTAINED WITHIN THESE MATERIALS. CONEXANT SHALL NOT BE LIABLE FOR ANY SPECIAL, INDIRECT, INCIDENTAL, OR CONSEQUENTIAL DAMAGES, INCLUDING WITHOUT LIMITATION, LOST REVENUES OR LOST PROFITS, WHICH MAY RESULT FROM THE USE OF THESE MATERIALS.

Conexant products are not intended for use in medical, lifesaving or life sustaining applications. Conexant customers using or selling Conexant products for use in such applications do so at their own risk and agree to fully indemnify Conexant for any damages resulting from such improper use or sale.

The following are trademarks of Conexant Systems, Inc.: Conexant™, the Conexant C symbol, and "What's Next in Communications Technologies"™. Product names or services listed in this publication are for identification purposes only, and may be trademarks of third parties. Third-party brands and names are the property of their respective owners.

Additional information, posted at www.conexant.com, is incorporated by reference.

Reader Response: Conexant strives to produce quality documentation and welcomes your feedback. Please send comments and suggestions to tech.pubs@conexant.com. For technical questions, contact your local Conexant sales office or field applications engineer.

www.conexant.com

General Information:

U.S. and Canada: (800) 854-8099

International: (949) 483-6996

Headquarters – Newport Beach

4311 Jamboree Rd.

Newport Beach, CA 92660-3007



CONEXANT™

What's next in communications technologies