

To our customers,

Old Company Name in Catalogs and Other Documents

On April 1st, 2010, NEC Electronics Corporation merged with Renesas Technology Corporation, and Renesas Electronics Corporation took over all the business of both companies. Therefore, although the old company name remains in this document, it is a valid Renesas Electronics document. We appreciate your understanding.

Renesas Electronics website: <http://www.renesas.com>

April 1st, 2010
Renesas Electronics Corporation

Issued by: Renesas Electronics Corporation (<http://www.renesas.com>)

Send any inquiries to <http://www.renesas.com/inquiry>.

Notice

1. All information included in this document is current as of the date this document is issued. Such information, however, is subject to change without any prior notice. Before purchasing or using any Renesas Electronics products listed herein, please confirm the latest product information with a Renesas Electronics sales office. Also, please pay regular and careful attention to additional and different information to be disclosed by Renesas Electronics such as that disclosed through our website.
2. Renesas Electronics does not assume any liability for infringement of patents, copyrights, or other intellectual property rights of third parties by or arising from the use of Renesas Electronics products or technical information described in this document. No license, express, implied or otherwise, is granted hereby under any patents, copyrights or other intellectual property rights of Renesas Electronics or others.
3. You should not alter, modify, copy, or otherwise misappropriate any Renesas Electronics product, whether in whole or in part.
4. Descriptions of circuits, software and other related information in this document are provided only to illustrate the operation of semiconductor products and application examples. You are fully responsible for the incorporation of these circuits, software, and information in the design of your equipment. Renesas Electronics assumes no responsibility for any losses incurred by you or third parties arising from the use of these circuits, software, or information.
5. When exporting the products or technology described in this document, you should comply with the applicable export control laws and regulations and follow the procedures required by such laws and regulations. You should not use Renesas Electronics products or the technology described in this document for any purpose relating to military applications or use by the military, including but not limited to the development of weapons of mass destruction. Renesas Electronics products and technology may not be used for or incorporated into any products or systems whose manufacture, use, or sale is prohibited under any applicable domestic or foreign laws or regulations.
6. Renesas Electronics has used reasonable care in preparing the information included in this document, but Renesas Electronics does not warrant that such information is error free. Renesas Electronics assumes no liability whatsoever for any damages incurred by you resulting from errors in or omissions from the information included herein.
7. Renesas Electronics products are classified according to the following three quality grades: “Standard”, “High Quality”, and “Specific”. The recommended applications for each Renesas Electronics product depends on the product’s quality grade, as indicated below. You must check the quality grade of each Renesas Electronics product before using it in a particular application. You may not use any Renesas Electronics product for any application categorized as “Specific” without the prior written consent of Renesas Electronics. Further, you may not use any Renesas Electronics product for any application for which it is not intended without the prior written consent of Renesas Electronics. Renesas Electronics shall not be in any way liable for any damages or losses incurred by you or third parties arising from the use of any Renesas Electronics product for an application categorized as “Specific” or for which the product is not intended where you have failed to obtain the prior written consent of Renesas Electronics. The quality grade of each Renesas Electronics product is “Standard” unless otherwise expressly specified in a Renesas Electronics data sheets or data books, etc.
 - “Standard”: Computers; office equipment; communications equipment; test and measurement equipment; audio and visual equipment; home electronic appliances; machine tools; personal electronic equipment; and industrial robots.
 - “High Quality”: Transportation equipment (automobiles, trains, ships, etc.); traffic control systems; anti-disaster systems; anti-crime systems; safety equipment; and medical equipment not specifically designed for life support.
 - “Specific”: Aircraft; aerospace equipment; submersible repeaters; nuclear reactor control systems; medical equipment or systems for life support (e.g. artificial life support devices or systems), surgical implantations, or healthcare intervention (e.g. excision, etc.), and any other applications or purposes that pose a direct threat to human life.
8. You should use the Renesas Electronics products described in this document within the range specified by Renesas Electronics, especially with respect to the maximum rating, operating supply voltage range, movement power voltage range, heat radiation characteristics, installation and other product characteristics. Renesas Electronics shall have no liability for malfunctions or damages arising out of the use of Renesas Electronics products beyond such specified ranges.
9. Although Renesas Electronics endeavors to improve the quality and reliability of its products, semiconductor products have specific characteristics such as the occurrence of failure at a certain rate and malfunctions under certain use conditions. Further, Renesas Electronics products are not subject to radiation resistance design. Please be sure to implement safety measures to guard them against the possibility of physical injury, and injury or damage caused by fire in the event of the failure of a Renesas Electronics product, such as safety design for hardware and software including but not limited to redundancy, fire control and malfunction prevention, appropriate treatment for aging degradation or any other appropriate measures. Because the evaluation of microcomputer software alone is very difficult, please evaluate the safety of the final products or system manufactured by you.
10. Please contact a Renesas Electronics sales office for details as to environmental matters such as the environmental compatibility of each Renesas Electronics product. Please use Renesas Electronics products in compliance with all applicable laws and regulations that regulate the inclusion or use of controlled substances, including without limitation, the EU RoHS Directive. Renesas Electronics assumes no liability for damages or losses occurring as a result of your noncompliance with applicable laws and regulations.
11. This document may not be reproduced or duplicated, in any form, in whole or in part, without prior written consent of Renesas Electronics.
12. Please contact a Renesas Electronics sales office if you have any questions regarding the information contained in this document or Renesas Electronics products, or if you have any other inquiries.

(Note 1) “Renesas Electronics” as used in this document means Renesas Electronics Corporation and also includes its majority-owned subsidiaries.

(Note 2) “Renesas Electronics product(s)” means any product developed or manufactured by or for Renesas Electronics.



THREE-PHASE SPINDLE MOTOR DRIVER FOR MONOLITHIC CD-ROM

DESCRIPTION

The μ PD16836 is a three-phase spindle motor driver for CD-ROM drives which consists of a CMOS control circuit and MOS bridge output. It employs a three-phase full-wave PWM driving method and a MOS FET in the output stage to lower the power consumption compared with drivers using conventional bipolar transistors.

FEATURES

- Low ON resistance (Sum of ON resistance of top and bottom transistors) $R_{on} = 1.2 \Omega$ (TYP.)
- Low power consumption using three-phase full-wave PWM driving system
- START/STOP pins enable braking operation in STOP mode
- Standby pin turns off internal circuitry in standby mode
- Low current consumption: $I_{DD} = 3\text{mA}$ (MAX.), $I_{DD(ST)} = 100 \mu\text{A}$ (MAX.)
- Internal thermal shutdown circuit
- Internal overcurrent protection circuit (can be externally set)
- Internal FG output function
- Reverse prevention circuit
- 24-pin plastic SOP (375 mil)

ORDERING INFORMATION

Part Number	Package
μ PD16836GT	24-pin plastic SOP (375 mil)

ABSOLUTE MAXIMUM RATINGS ($T_A = 25 \text{ }^\circ\text{C}$)

Parameter	Symbol	Conditions	Ratings	Unit
Supply voltage	V_{DD}		-0.5 to +7.0	V
	V_M		-0.5 to +15.0	V
Input voltage	V_{IN}		-0.5 to $V_{DD} + 0.5$	V
Instantaneous output current ^{Note 1}	I_{OP}	$PW \leq 5 \text{ ms}$, Duty $\leq 40 \%$	± 1.3	A
Power dissipation ^{Note 2}	P_T		1.25	W
Peak junction temperature	$T_{CH(MAX)}$		150	$^\circ\text{C}$
Storage temperature range	T_{stg}		-55 to +150	$^\circ\text{C}$

- Notes**
1. Permissible current value per one phase, when mounted on the printed circuit board
 2. When mounted on the printed circuit board (100 mm \times 100 mm \times 1 mm, glass epoxy)

The information in this document is subject to change without notice.

RECOMMENDED OPERATING RANGE

Parameter	Symbol	MIN.	TYP.	MAX.	Unit
Supply voltage	V _{DD}	4.5		5.5	V
	V _M	10.8		13.2	V
Instantaneous output current	I _{OP}			1.0	A/phase
CL pin input voltage	V _{CL}	0.3		1.0	V
Operating temperature range	T _A	-20		75	°C

ELECTRICAL SPECIFICATIONS (Unless otherwise specified, T_A = 25 °C, V_{DD} = 5 V, V_M = 12 V)

Parameter	Symbol	Conditions	MIN.	TYP.	MAX.	Unit
<Overall>						
Current consumption 1 (V _{DD})	I _{DD}	STB = L		1.5	3.0	mA
Current consumption 2 (standby)	I _{DD (ST)}	STB = H			0.1	mA
<ST/SP, REV, STB>						
High-level input voltage	V _{IH}	ST/SP = H	0.6×V _{DD}		V _{DD}	V
Low-level input voltage	V _{IL}	ST/SP = L			0.8	V
Input pull-down resistor	R _{IND}		60	100	140	kΩ
<Control circuit>						
Triangular wave oscillation frequency	f _{PWM}	C _T = 100 pF	40	100	250	kHz
<Hole amplifier>						
In-phase input voltage range	V _{Hch}		1.0		2.8	V
Hysteresis voltage	V _{Hhis}			20		mV
Input bias current	I _{Hbias}				1.0	μA
<FG output>						
IND pin high-level voltage	V _{FG_H}	I _o = -4 mA	3.5			V
IND pin low-level voltage	V _{FG_L}	I _o = +4 mA			0.5	V
<Output block>						
Output ON resistance	R _{ON} ^{Note}	I _o = 200 mA, T _A = -20 to 70 °C		1.2	1.8	Ω
Output turn-ON time	t _{ON}	R _M = 5 Ω (Star connection)		1.0	2.0	μs
Output turn-OFF time	t _{OFF}			1.0	2.0	μs
<Torque command>						
Control reference input voltage range	ECR		1.5		3.0	V
Control input voltage range	EC		1.0		3.5	V
Input current	I				100	μA
Input differential voltage	ECR-EC	Duty = 100 %		0.32		V
DEADZONE (+)	EC d+		5	75	150	mV
DEADZONE (-)	EC d-		-150	-75	-150	mV

Note Sum of ON resistance of top and bottom transistors

The thermal shutdown circuit operates at T_{CH} ≥ 150 °C

The low-voltage malfunction prevention circuit (UVLO) operates at V_{DD} = 4 V (TYP.)

PIN CONFIGURATION

REV	1	24	V _{DD}
ST/SP	2	23	C _T
STB	3	22	IND
V _M	4	21	EC
OUT0	5	20	ECR
NC	6	19	H2+
OUT1	7	18	H2-
RF	8	17	H1+
OUT2	9	16	H1-
NC	10	15	H0+
NC	11	14	H0-
GND	12	13	C _L

PIN FUNCTIONS

Package: 24-pin plastic SOP (375 mil)

Pin Number	Pin Name	I/O	Pin Functions
1	REV	I	Reverse operation input pin (reverse brake)
2	ST/SP	I	Start/stop input pin
3	STB	I	Standby operation input pin
4	V _M	-	Motor block power supply voltage (12 V)
5	OUT0	O	Motor connection pin (output pin)
6	NC	-	Open pin
7	OUT1	O	Motor connection pin
8	RF	I	Sense resistor connection pin
9	OUT2	O	Motor connection pin
10	NC	-	Open pin
11	NC	-	Open pin
12	GND	-	GND pin
13	C _L	I	Reference voltage input pin for overcurrent detection
14	H0-	I	Hole signal input pin
15	H0+	I	Hole signal input pin
16	H1-	I	Hole signal input pin
17	H1+	I	Hole signal input pin
18	H2-	I	Hole signal input pin
19	H2+	I	Hole signal input pin
20	ECR	I	Control reference voltage input pin
21	EC	I	Control voltage input pin
22	IND	O	Index signal output pin
23	C _T	I	Capacitor connection pin for oscillator frequency setting
24	V _{DD}	-	Control block power supply voltage input pin (5 V)

BLOCK DIAGRAM

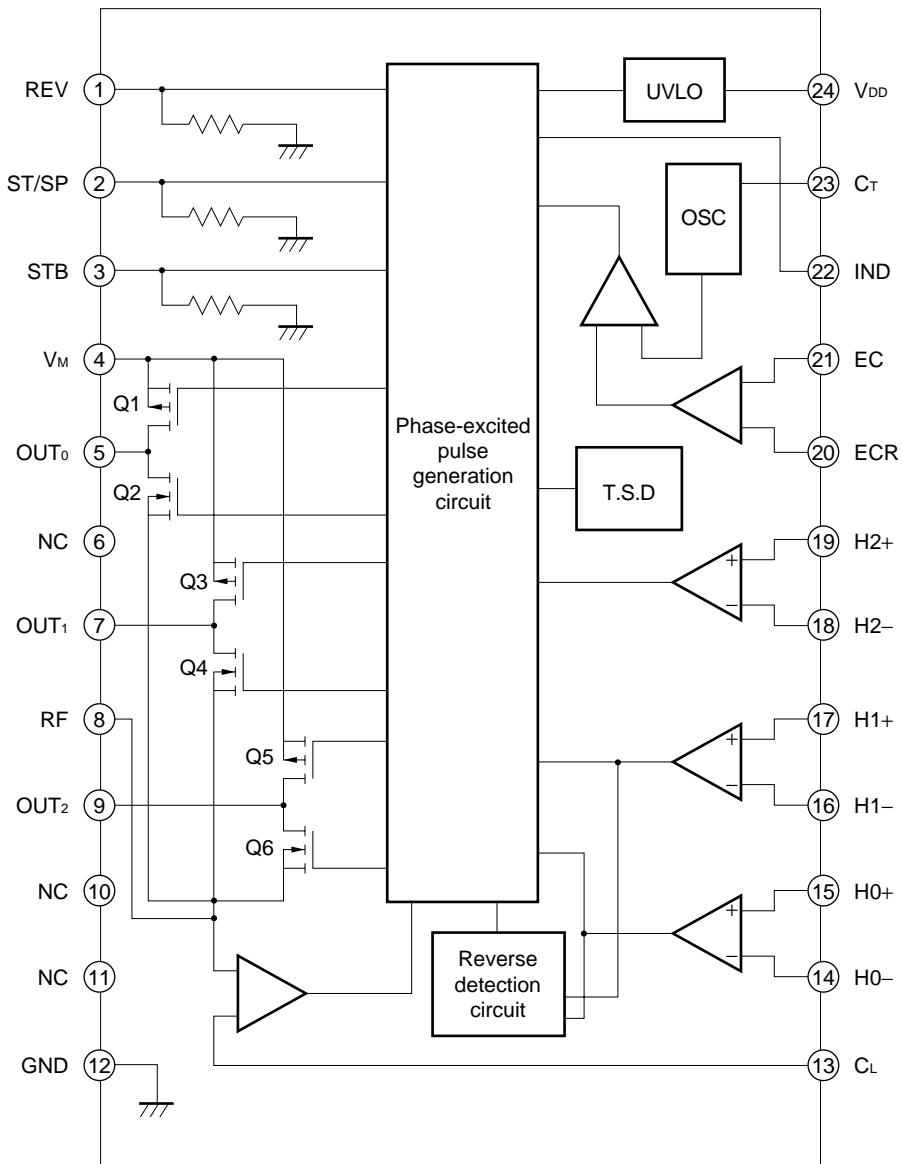

TYPICAL CHARACTERISTIC CURVES (T_A = 25 °C)

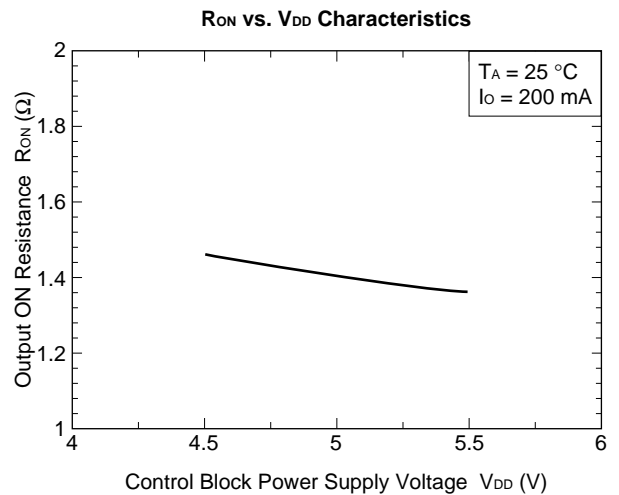
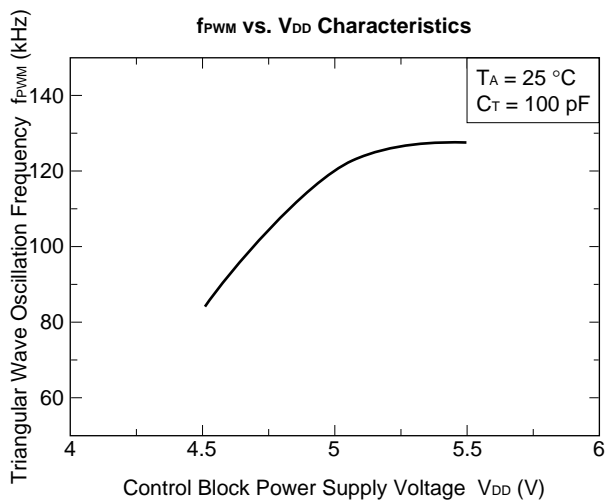
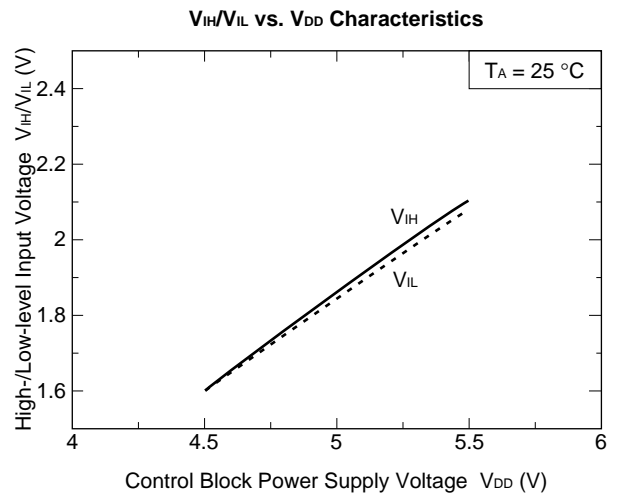
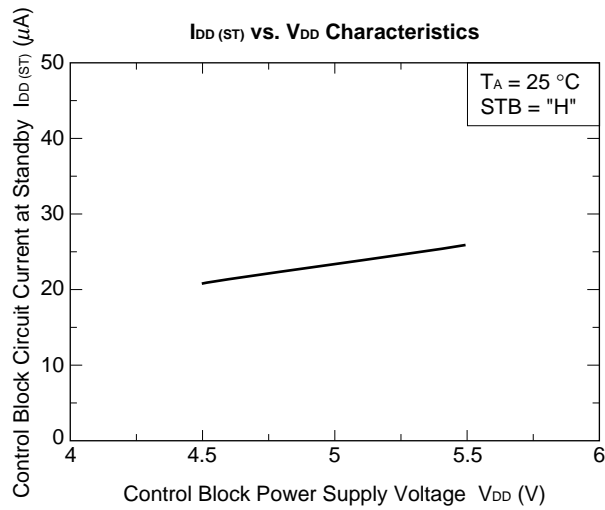
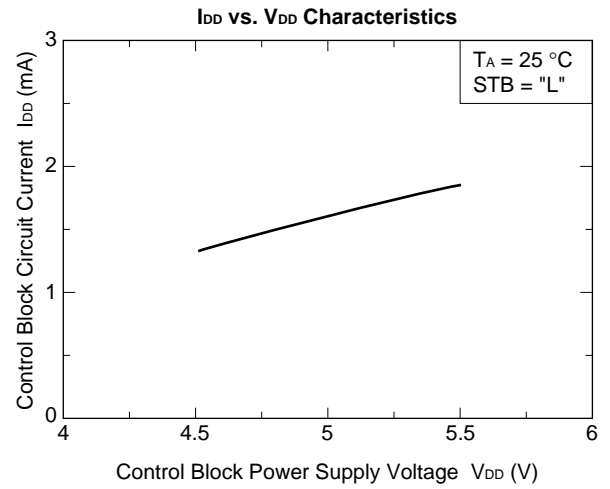
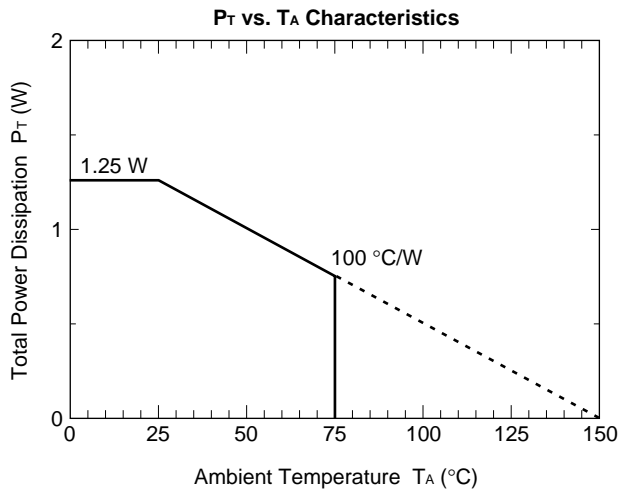

R_{ON} vs. T_A Characteristics

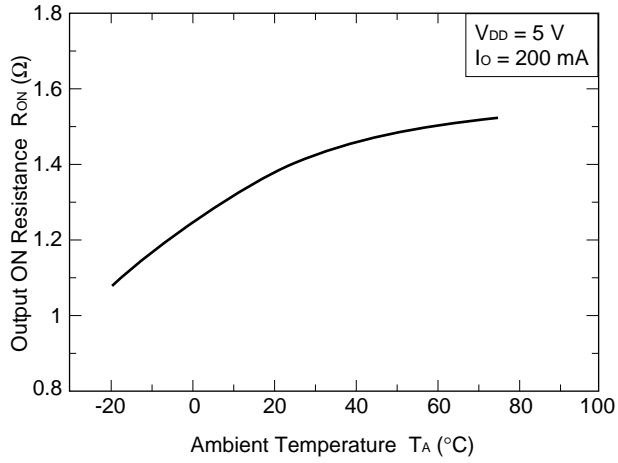

t_{ON}, t_{OFF} vs. V_{DD} Characteristics

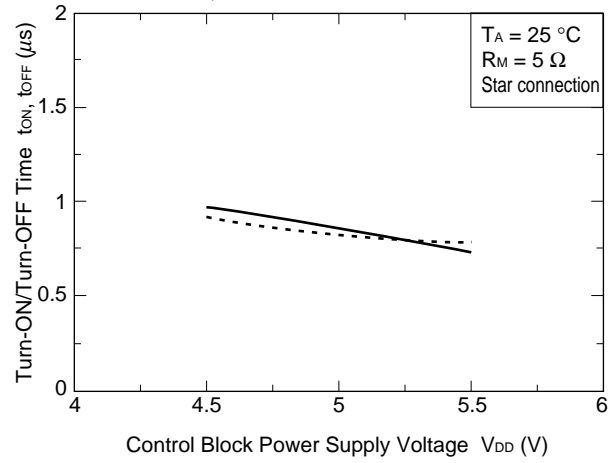

ECR – EC vs. V_{DD} Characteristics

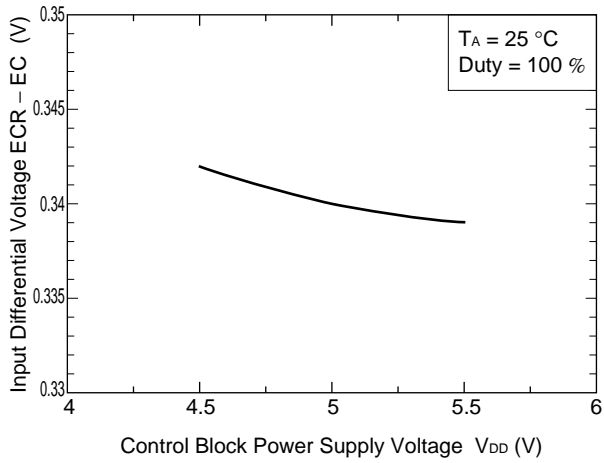

I vs. V_{DD} Characteristics

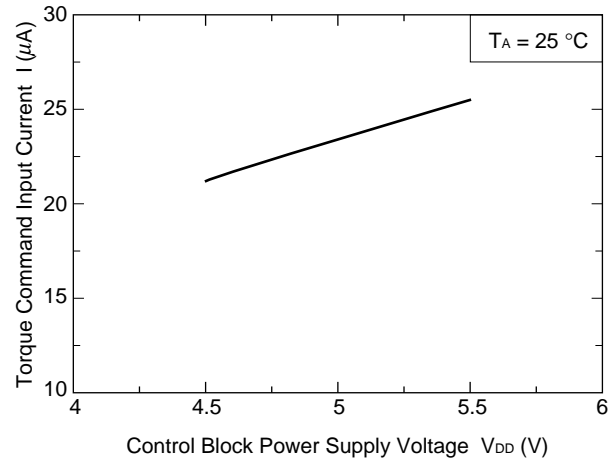

EC d₊, EC d₋ vs. V_{DD} Characteristics

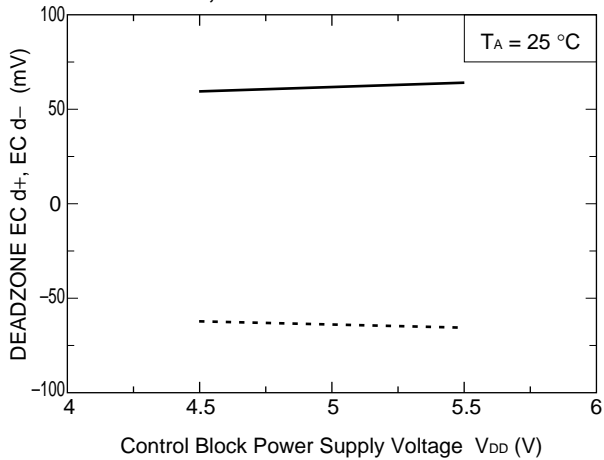

FUNCTION OPERATION TABLE

(1) ST/SP = "H"

Input Signal				Circuit Operation Mode	Source → Sink
CMP0	CMP1	CMP2	PWM		
H	H	L	H	Operation	W → V
H	H	L	L	Brake	
H	L	L	H	Operation	W → U
H	L	L	L	Brake	
H	L	H	H	Operation	V → U
H	L	H	L	Brake	
L	L	H	H	Operation	V → W
L	L	H	L	Brake	
L	H	H	H	Operation	U → W
L	H	H	L	Brake	
L	H	L	H	Operation	U → V
L	H	L	L	Brake	

Brake: For circuit operation, each high-side switch of the source and sink turns ON.

(2) ST/SP = "L"

Input Signal				Circuit Operation Mode
CMP0	CMP1	CMP2	PWM	
-	-	-	-	Stop

Remark Q1, Q3, and Q5 are ON. Q2, Q4, and Q6 are OFF.

(3) Torque command

The relationship between the control reference voltage (ECR) and control voltage (ECR – EC), and torque is as follows. Dead band width is 150 mV (TYP).

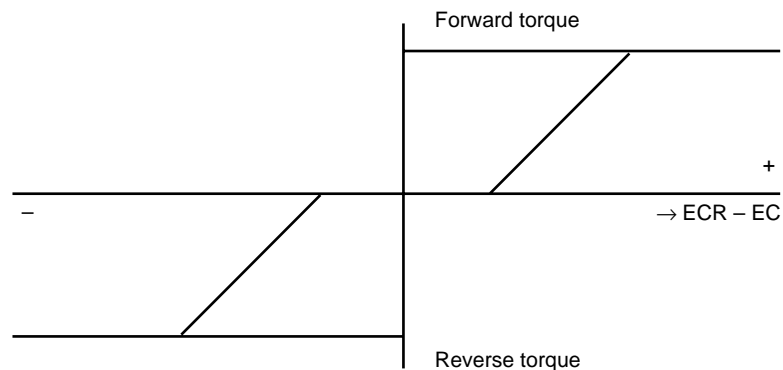

	Reverse Pin Voltage (REV)	
	L	H
ECR > EC	Forward	Reverse ^{Note}
ECR < EC	Reverse ^{Note}	Stop

Note Stops after detecting reverse.

(4) Standby mode

The internal power supply for the μPD16836 is turned off by setting the standby mode.

Each pin output is high-impedance in the standby mode. The internal oscillation block also stops, and the circuit current can be reduced.

After the normal operation mode has been set, a few of 10's of μs are necessary for the motor to restart.

STB Pin	Operation Mode
L	Normal mode
H	Standby mode

TIMING CHART

(1) Hole signal input

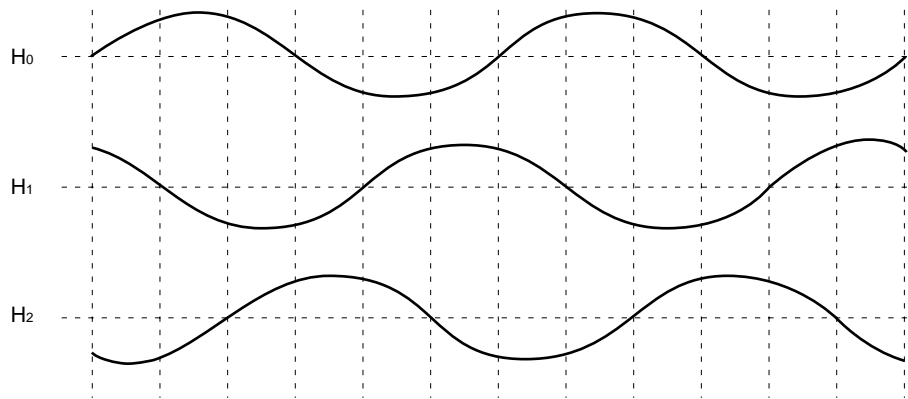

(2) CMP signal

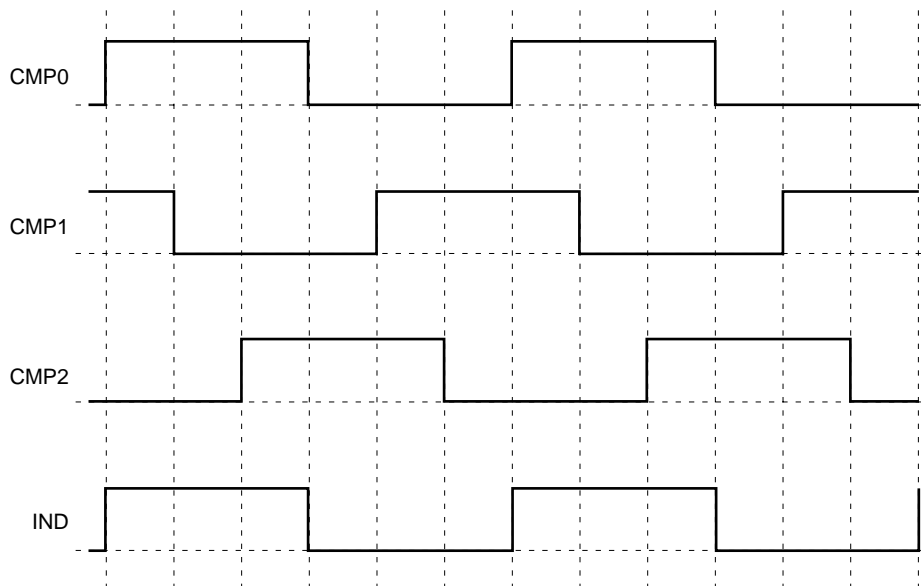

(3) Output MOSFET driving and comparator selection

Q1		SW	SW		ON	ON		SW	SW		ON	ON	
Q2		SW	SW					SW	SW				
Q3	SW		ON	ON		SW	SW		ON	ON		SW	SW
Q4	SW					SW	SW					SW	SW
Q5	ON	ON		SW	SW		ON	ON		SW	SW		ON
Q6				SW	SW					SW	SW		

(4) Motor driving waveform

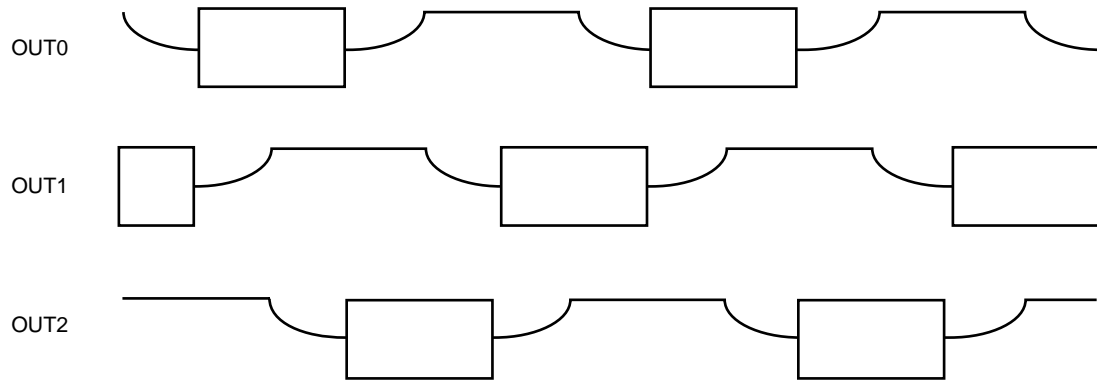

PACKAGE DRAWING

24 PIN PLASTIC SOP (375 mil)

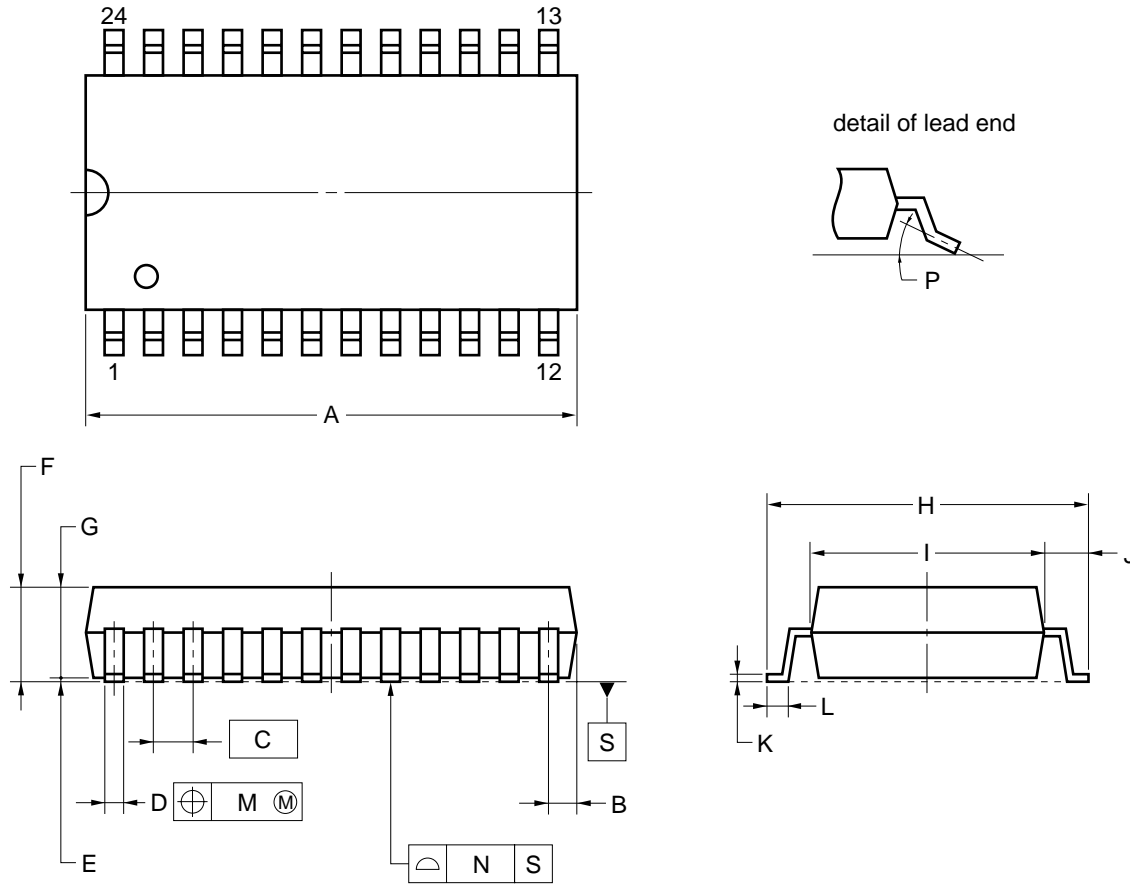

NOTE

1. Controlling dimension — millimeter.
2. Each lead centerline is located within 0.12 mm (0.005 inch) of its true position (T.P.) at maximum material condition.

ITEM	MILLIMETERS	INCHES
A	15.3 ^{+0.41} _{-0.2}	0.602 ^{+0.017} _{-0.008}
B	0.87 MAX.	0.035 MAX.
C	1.27 (T.P.)	0.050 (T.P.)
D	0.42 ^{+0.08} _{-0.07}	0.017 ^{+0.003} _{-0.004}
E	0.125±0.075	0.005±0.003
F	2.9 MAX.	0.115 MAX.
G	2.50±0.2	0.098 ^{+0.009} _{-0.008}
H	10.3±0.2	0.406 ^{+0.008} _{-0.009}
I	7.2±0.2	0.283 ^{+0.009} _{-0.008}
J	1.6±0.2	0.063±0.008
K	0.17 ^{+0.08} _{-0.07}	0.007 ^{+0.003} _{-0.004}
L	0.8±0.2	0.031 ^{+0.009} _{-0.008}
M	0.12	0.005
N	0.10	0.004
P	3° ^{+7°} _{-3°}	3° ^{+7°} _{-3°}

P24GT-50-375B-2

ELECTRICAL SPECIFICATIONS

Solder this product under the following recommended conditions.

For details of the recommended soldering conditions, refer to information document **Semiconductor Device Mounting Technology Manual (C10535E)**.

For soldering methods and conditions other than those recommended, consult NEC.

Soldering Methods	Soldering Conditions	Recommended Conditions Symbol
Infrared reflow	Package peak temperature: 235 °C, Time: 30 secs. max. (210 °C min.), Number of times: three times max., Number of days: none ^{Note} , Flux: Rosin-based flux with little chlorine content (chlorine: 0.2 Wt% max.) is recommended.	IR35-00-3
VPS	Package peak temperature: 215 °C, Time: 40 secs. max. (200 °C min.), Number of times: three times max., Number of days: none ^{Note} , Flux: Rosin-based flux with little chlorine content (chlorine: 0.2 Wt% max.) is recommended.	VP15-00-1
Wave soldering	Package peak temperature: 260 °C, Time: 10 secs. max., Preheating temperature: 120 °C max., Number of times: once, Flux: Rosin-based flux with little chlorine content (chlorine: 0.2 Wt% max.) is recommended.	WS60-00-1

Note Number of days in storage after the dry pack has been opened. The storage conditions are at 25 °C, 65% RH MAX.

Caution Do not use two or more soldering methods in combination.

No part of this document may be copied or reproduced in any form or by any means without the prior written consent of NEC Corporation. NEC Corporation assumes no responsibility for any errors which may appear in this document.

NEC Corporation does not assume any liability for infringement of patents, copyrights or other intellectual property rights of third parties by or arising from use of a device described herein or any other liability arising from use of such device. No license, either express, implied or otherwise, is granted under any patents, copyrights or other intellectual property rights of NEC Corporation or others.

While NEC Corporation has been making continuous effort to enhance the reliability of its semiconductor devices, the possibility of defects cannot be eliminated entirely. To minimize risks of damage or injury to persons or property arising from a defect in an NEC semiconductor device, customers must incorporate sufficient safety measures in its design, such as redundancy, fire-containment, and anti-failure features.

NEC devices are classified into the following three quality grades:

"Standard", "Special", and "Specific". The Specific quality grade applies only to devices developed based on a customer designated "quality assurance program" for a specific application. The recommended applications of a device depend on its quality grade, as indicated below. Customers must check the quality grade of each device before using it in a particular application.

Standard: Computers, office equipment, communications equipment, test and measurement equipment, audio and visual equipment, home electronic appliances, machine tools, personal electronic equipment and industrial robots

Special: Transportation equipment (automobiles, trains, ships, etc.), traffic control systems, anti-disaster systems, anti-crime systems, safety equipment and medical equipment (not specifically designed for life support)

Specific: Aircrafts, aerospace equipment, submersible repeaters, nuclear reactor control systems, life support systems or medical equipment for life support, etc.

The quality grade of NEC devices is "Standard" unless otherwise specified in NEC's Data Sheets or Data Books. If customers intend to use NEC devices for applications other than those specified for Standard quality grade, they should contact an NEC sales representative in advance.

Anti-radioactive design is not implemented in this product.