

December 1992

DESCRIPTION

The SSI 32R516 is a bipolar monolithic integrated circuit designed for use with a center-tapped ferrite or MIG recording heads. The SSI 32R516 offers the performance upgrades of the SSI 32R511 along with improved head port characteristics and increased read gain. It provides a low noise read path, write current control, and data protection circuitry for as many as 8 channels. The SSI 32R516 requires +5V and +12V power supplies and is available in a variety of packages.

The SSI 32R516R performs the same function as the SSI 32R516 with the addition of internal 650Ω damping resistors. The SSI 32R516M and SSI 32R516RM are functionally equivalent to the SSI 32R516 and SSI 32R516R however, they have the mirror image pin arrangement to simplify layout when using multiple devices.

FEATURES

- **High performance**
Read mode gain = 120 V/V
Input noise = 1.3 nV/√Hz maximum
Input capacitance = 18 pF
Write current range = 10 mA to 60 mA
- **Enhanced system write to read recovery time**
- **Power supply fault protection**
- **Pin compatible with the SSI 32R501 & SSI 32R511**
- **Designed for center-tapped ferrite or MIG heads**
- **Programmable write current source**
- **Easily multiplexed for larger systems**
- **Includes write unsafe detection**
- **TTL compatible control signals**
- **+5V, +12V power supplies**
- **Mirror image pin arrangements**

BLOCK DIAGRAM

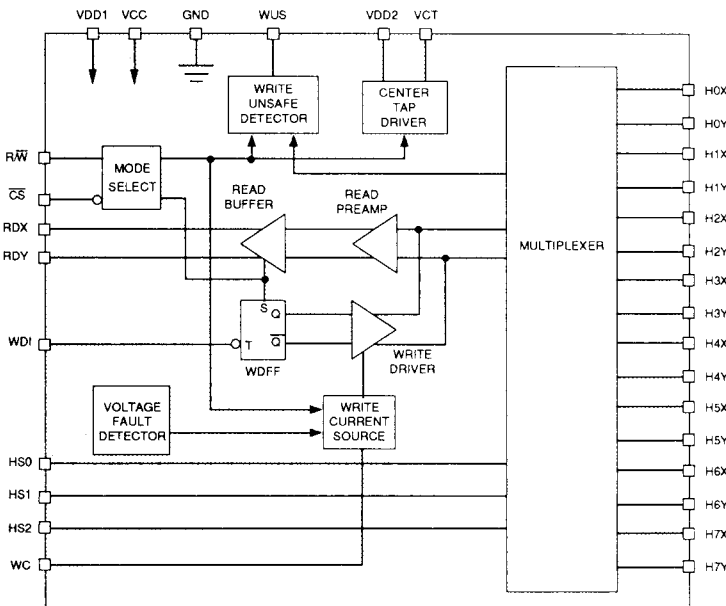

PIN DIAGRAM

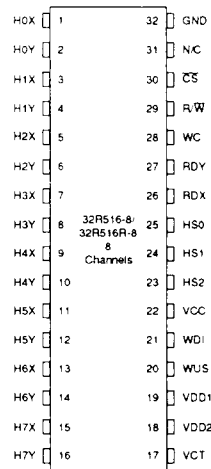

32-Lead SOW

SSI 32R516/516R

4, 6, 8-Channel Ferrite/MIG

Read/Write Device

CIRCUIT OPERATION

The SSI 32R516 gives the user the ability to address up to 8 center-tapped ferrite heads and provide write drive or read amplification. Head selection and mode control is accomplished using the HS_n, \overline{CS} and R/ \overline{W} inputs as shown in tables 1 & 2. Internal pullups are provided for the \overline{CS} & R/ \overline{W} inputs to force the device into a non-writing condition if either control line is opened accidentally.

TABLE 1: Mode Select

\overline{CS}	R/ \overline{W}	MODE
0	0	Write
0	1	Read
1	X	Idle

TABLE 2: Head Select

HS2	HS1	HS0	HEAD
0	0	0	0
0	0	1	1
0	1	0	2
0	1	1	3
1	0	0	4
1	0	1	5
1	1	0	6
1	1	1	7

0 = Low level 1 = High level

WRITE MODE

Taking both \overline{CS} and R/ \overline{W} low selects write mode which configures the SSI 32R516 as a current switch and activates the Write Unsafe (WUS) detector circuitry. Write current is toggled between the X and Y side of the selected head on each high to low transition of the Write Data Input (WDI). Note that a preceding read mode selection initializes the Write Data Flip-Flop, WDFF, to pass write current through the "X" side of the head. The zero-peak write current magnitude is programmed by an external resistor R_{wc} from pin WC to GND and is given by:

$$I_w = K/R_{wc}, \text{ where } K = \text{Write Current Constant}$$

The Write Unsafe detection circuitry monitors voltage transitions at the selected head connections and flags any of the following conditions as a high level on the Write Unsafe open collector output:

- Head open
- WDI frequency too low
- Device not selected
- Head center tap open
- Device in read mode
- No write current

Two negative transitions on WDI, after the fault is corrected, will clear the WUS flag.

To further assure data security a voltage fault detection circuit prevents application of write current during power loss or power sequencing.

To enhance write to read recovery time the change in RDX, RDY common mode voltage is minimized by biasing these outputs to a level within the read mode range when in write mode.

Power dissipation in write mode may be reduced by placing a resistor (RCT) between VDD1 & VDD2. The optimum resistor value is $82\Omega \times 60/I_w$ (I_w in mA). At low write currents (<15 mA) read mode dissipation is higher than write mode and RCT, though recommended, may not be considered necessary. In this case VDD2 is connected directly to VDD1.

READ MODE

Taking \overline{CS} low and R/ \overline{W} high selects read mode which configures the SSI 32R516 as a low noise differential amplifier for the selected head. The RDX and RDY outputs are driven by emitter followers and are in phase with the "X" and "Y" head ports. These outputs should be AC coupled to the load. The internal write current source is gated off in read mode eliminating the need for any external gating.

Read mode selection also initializes the Write Data Flip-Flop (WDFF) to pass write current through the "X" side of the head at a subsequent write mode selection.

IDLE MODE

Taking \overline{CS} high selects the idle mode which switches the RDX, RDY outputs into a high impedance state and deactivates the internal write current source. This facilitates multi-device installations by allowing the read outputs to be wire OR'ed and the write current programming resistor to be common to all devices.

SSI 32R516/516R 4, 6, 8-Channel Ferrite/MIG Read/Write Device

1

PIN DESCRIPTIONS

NAME	I/O	DESCRIPTION
HS0-HS2	I	Head Select
\overline{CS}	I	Chip Select: a low level enables device
R/W	I	Read/Write: a high level selects read mode
WUS	O*	Write Unsafe: a high level indicates an unsafe writing condition
WDI	I	Write Data In: negative transition toggles direction of head current
H0X-H7X H0Y-H7Y	I/O	X, Y head connections
RDX, RDY	O*	X, Y Read Data: differential read signal out
WC	*	Write Current: used to set the magnitude of the write current
VCT	-	Voltage Center Tap: voltage source for head center tap
VCC	-	+5V
VDD1	-	+12V
VDD2	-	Positive power supply for the center tap voltage source
GND	-	Ground

*When more than one R/W device is used, these signals can be wire OR'ed.

ELECTRICAL SPECIFICATIONS

ABSOLUTE MAXIMUM RATINGS (All voltages referenced to GND. Currents into device are positive.)

PARAMETER		VALUE	UNITS
DC Supply Voltage	VDD1	-0.3 to +14	VDC
DC Supply Voltage	VDD2	-0.3 to +14	VDC
DC Supply Voltage	VCC	-0.3 to +6	VDC
Digital Input Voltage Range	VIN	-0.3 to VCC + 0.3	VDC
Head Port Voltage Range	VH	-0.3 to VDD1 + 0.3	VDC
WUS Pin Voltage Range	Vwus	-0.3 to +14	VDC
Write Current Zero Peak	IW	90	mA
RDX, RDY Output Current	Io	-10	mA
VCT Output Current	Ivct	-90	mA
WUS Output Current	Iwus	+12	mA
Storage Temperature Range	Tstg	-65 to 150	°C
Lead Temperature PDIP, Flat Pack (10 sec Soldering)		260	°C
Package Temperature PLCC, SO (20 sec Reflow)		215	°C

SSI 32R516/516R

4, 6, 8-Channel Ferrite/MIG

Read/Write Device

RECOMMENDED OPERATION CONDITIONS

PARAMETER	CONDITIONS	MIN	NOM	MAX	UNITS
DC Supply Voltage	VDD1	10.8	12.0	13.2	VDC
DC Supply Voltage	VCC	4.5	5.0	5.5	VDC
Head Inductance	Lh	5		10	μ H
Damping Resistor	RD	32R516 only		2000	Ω
RCT Resistor	RCT*	lw = 60 mA	82		Ω
Write Current	IW	10		60	mA
Junction Temperature Range	Tj	+25		+135	$^{\circ}$ C

*For lw = 60 mA. At other lw levels refer to Applications Information that follows this specification.

DC CHARACTERISTICS

(Unless otherwise specified, recommended operating conditions apply.)

POWER SUPPLY

PARAMETER	CONDITIONS	MIN	NOM	MAX	UNITS
VCC Supply Current	Read/Idle Mode			30	mA
	Write Mode			30	mA
VDD Supply Current (sum of VDD1 and VDD2)	Idle Mode			20	mA
	Read Mode			40	mA
	Write Mode			20 + lw	mA
Power Dissipation (Tj = +125 $^{\circ}$ C)	Idle Mode			400	mW
	Read Mode			620	mW
	Write Mode, IW = 45 mA, RCT = 0 Ω			800	mW
	Write Mode, IW = 45 mA, RCT = 110 Ω			610	mW
	Write Mode, IW = 60 mA RCT = 82 Ω			680	mW

SSI 32R516/516R 4, 6, 8-Channel Ferrite/MIG Read/Write Device

1

DC CHARACTERISTICS (continued)

DIGITAL I/O

PARAMETER	CONDITIONS	MIN	NOM	MAX	UNITS
VIL Input Low Voltage				0.8	VDC
VIH Input High Voltage		2.0		VCC + 0.3	VDC
IIL Input Low Current	VIL = 0.8V	-0.4			mA
IIH Input High Current	VIH = 2.0V			100	μA
VOL WUS Output Low Voltage	IOL = 8 mA			0.5	VDC
IOH WUS Output High Current	VOH = 5.0V			100	μA

WRITE MODE

Center Tap Voltage	VCT	Write Mode		6.9		VDC
Head Current (per side)		Write Mode, 0 ≤ VCC ≤ 3.7V, 0 ≤ VDD1 ≤ 8.7V	-200		200	μA
Write Current Range			10		60	mA
Write Current Constant "K"		IW = 10 - 60 mA	2.375		2.80	V
Iwc to Head Current Gain				0.99		mA/mA
Unselected Head Leakage Current					85	μA
RDX, RDY Output Offset Voltage		Write/Idle Mode	-20		+20	mV
RDX, RDY Common Mode Output Voltage		Write/Idle Mode		5.5		VDC
RDX, RDY Leakage		RDX, RDY = 6V Write/Idle Mode	-100		100	μA

READ MODE

Center Tap Voltage		Read Mode		4.2		VDC
Head Current (per side)		Read or Idle Mode 0 ≤ VCC ≤ 5.5V 0 ≤ VDD1 ≤ 13.2V	-200		200	μA
Input Bias Current (per side)					45	μA
Input Offset Voltage		Read Mode	-4		+4	mV
Common Mode Output Voltage		Read Mode	4.5	5.5	6.5	VDC

SSI 32R516/516R

4, 6, 8-Channel Ferrite/MIG

Read/Write Device

DYNAMIC CHARACTERISTICS AND TIMING

(Unless otherwise specified, recommended operating conditions apply and $I_W = 35 \text{ mA}$, $L_h = 5 \mu\text{H}$, $R_d = 750\Omega$ (32R516) only, $f(\text{WDI}) = 5 \text{ MHz}$, $CL(\text{RDX}, \text{RDY}) \leq 35 \text{ pF}$.)

WRITE MODE

PARAMETER	CONDITIONS	MIN	NOM	MAX	UNITS
Differential Head Voltage Swing		7.0			V(pk)
Unselected Head Transient Current				2	mA(pk)
Differential Output Capacitance				15	pF
Differential Output Resistance	32R516	10K			Ω
	32R516R	430	650	870	Ω
WDI Transition Frequency	WUS = low	125			kHz

READ MODE

Differential Voltage Gain	$V_{in} = 1 \text{ mVpp @ } 300 \text{ kHz}$, $RL(\text{RDX}), RL(\text{RDY}) = 1 \text{ K}\Omega$	100	120	140	V/V
Dynamic Range	AC Input Voltage, V_i , Where Gain Falls by 10%. $V + f = 300 \text{ KHz}$	-3			mVpp
Bandwidth (-3dB)	$ Z_s < 5\Omega$, $V_{in} = 1 \text{ mVpp}$	30			MHz
Input Noise Voltage	$BW = 15 \text{ MHz}$, $L_h = 0$, $R_h = 0$		1.0	1.3	nV/ $\sqrt{\text{Hz}}$
Differential Input Capacitance	$f = 5 \text{ MHz}$		14	18	pF
Differential Input Resistance	32R516, $f = 5 \text{ MHz}$	2K			Ω
Differential Input Resistance	32R516R, $f = 5 \text{ MHz}$	350		800	Ω
Common Mode Rejection Ratio	$V_{cm} = VCT + 100 \text{ mVpp}$ @ 5 MHz	50			dB
Power Supply Rejection Ratio	$100 \text{ mVpp @ } 5 \text{ MHz}$ on VDD1, VDD2 or VCC	45			dB
Channel Separation	Unselected Channels: $V_{in} = 100 \text{ mVpp @ } 5 \text{ MHz}$; Selected Channel: $V_{in} = 0 \text{ mVpp}$	45			dB
Single Ended Output Resistance	$f = 5 \text{ MHz}$			30	Ω
Output Current	AC Coupled Load, RDX to RDY	± 2.1			mA

DYNAMIC CHARACTERISTICS AND TIMING (continued)

SWITCHING CHARACTERISTICS

PARAMETER	CONDITIONS	MIN	NOM	MAX	UNITS
R \overline{W} To Write	Delay to 90% of Write Current		.15	.7	μ s
R \overline{W} to Read	Delay to 90% of 100 mV, 10 MHz Read Signal Envelope or to 90% decay of Write Current		.25	.7	μ s
\overline{CS} to Select	Delay to 90% of Write Current or to 90% of 100 mV, 10 MHz Read Signal Envelope		.2	1.0	μ s
\overline{CS} to Unselect	Delay to 90% Decay of Write Current		.1	1.0	μ s
HS0 - HS2 to any head	Delay to 90% of 100 mV, 10 MHz Read Signal Envelope		.25	1.0	μ s
WUS, Safe to Unsafe - TD1	$I_w = 35$ mA	1.6		8.0	μ s
WUS, Unsafe to Safe - TD2	$I_w = 35$ mA			1.0	μ s
Head Current ($L_h = 0 \mu$ H, $R_h = 0\Omega$)					
Prop. Delay - TD3	From 50% Points			25	ns
Asymmetry	WDI has 50% Duty Cycle and 1ns Rise/Fall Time			1	ns
Rise/Fall Time	10% - 90% Points			20	ns

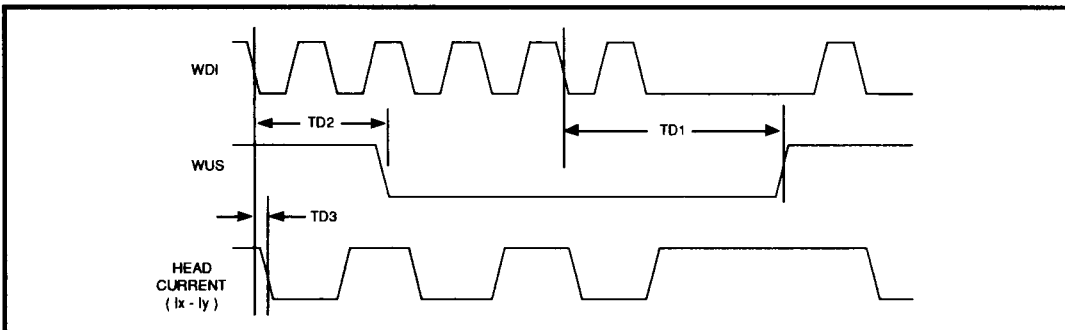

FIGURE 1: Write Mode Timing Diagram

SSI 32R516/516R

4, 6, 8-Channel Ferrite/MIG

Read/Write Device

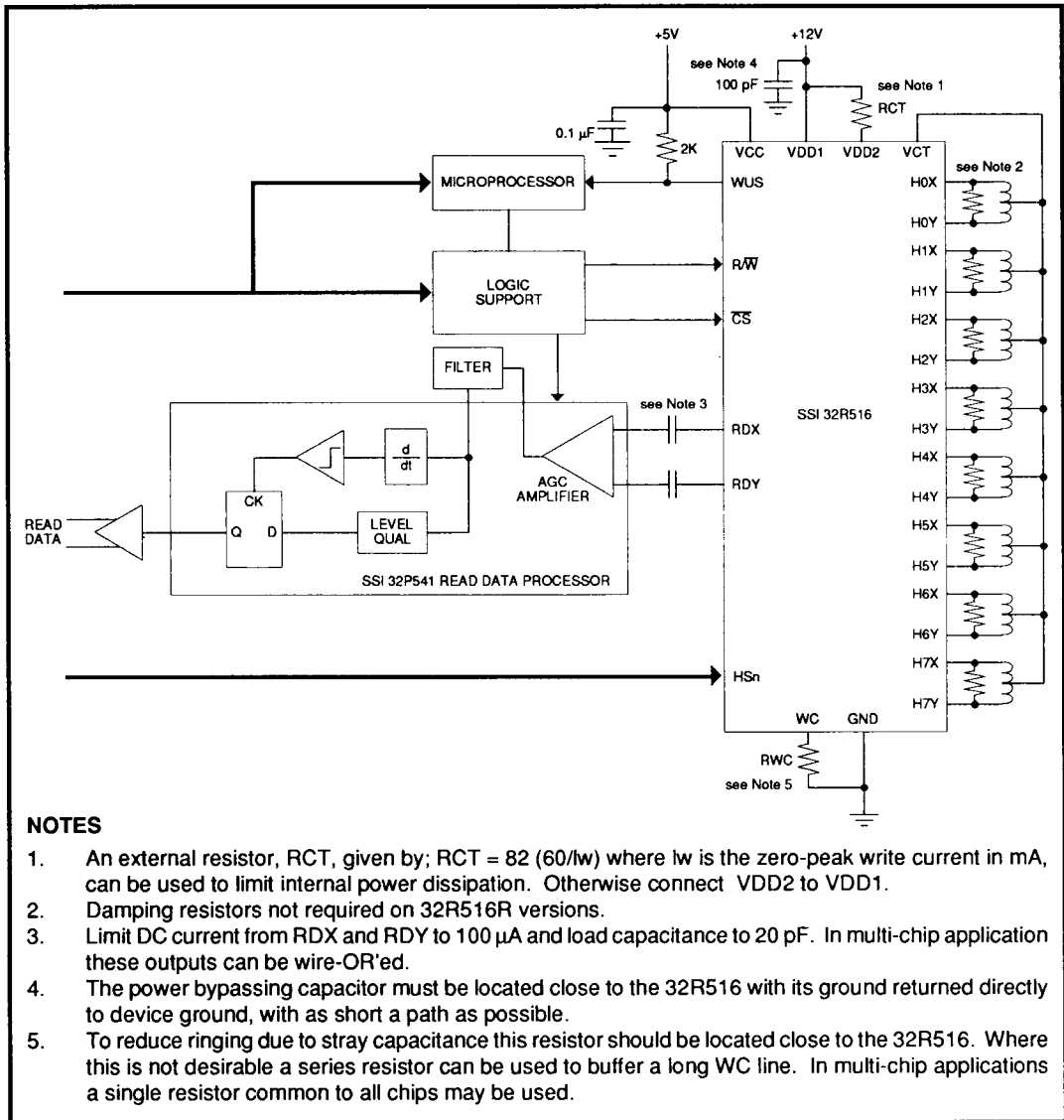
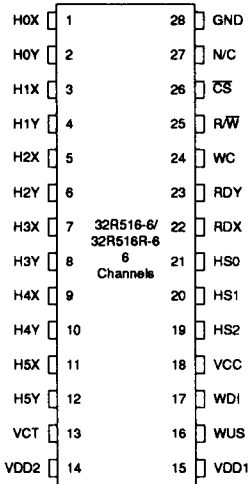

FIGURE 2: Applications Information

SSI 32R516/516R 4, 6, 8-Channel Ferrite/MIG Read/Write Device

1

PACKAGE PIN DESIGNATIONS (Top View)



28-Lead SOL

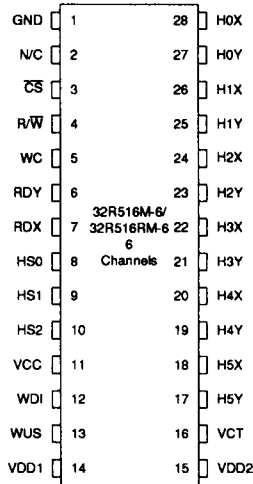

28-Lead SOL
Mirror Image

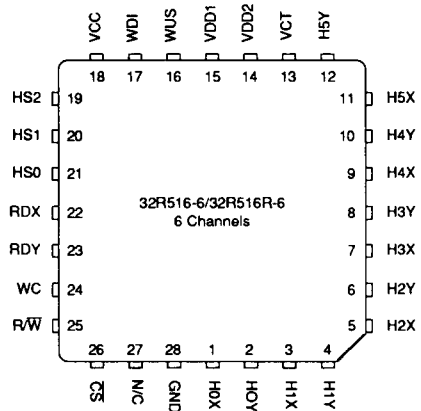

28-Lead PLCC

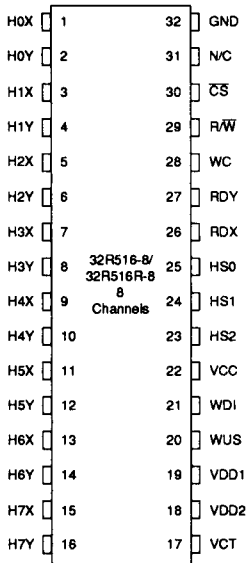

32-Lead SOW

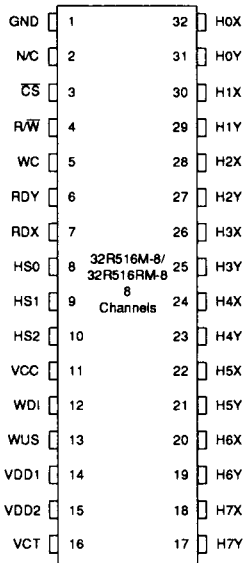

32-Lead SOW
Mirror Image

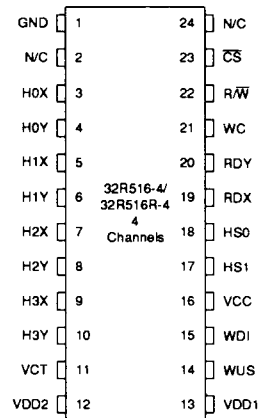

24-Lead SOL

SSI 32R516/516R

4, 6, 8-Channel Ferrite/MIG

Read/Write Device

PACKAGE PIN DESIGNATIONS (Continued)

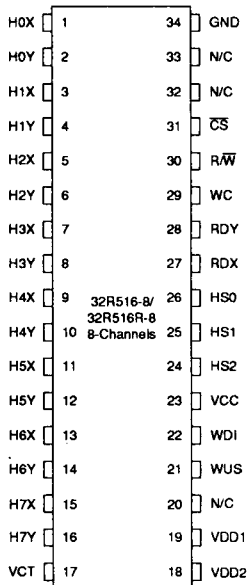

34-Lead SOL

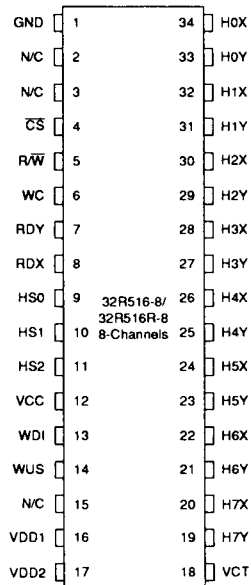

**34-Lead SOL
Mirror Image**

THERMAL CHARACTERISTICS: θ_{ja}

24-lead	SOL	75°C/W
28-lead	PLCC	65°C/W
	SOL	75°C/W
32-lead	SOW	60°C/W
34-lead	SOL	70°C/W
44-lead	PLCC	50°C/W

SSI 32R516/516R

4, 6, 8-Channel Ferrite/MIG

Read/Write Device

1

ORDERING INFORMATION

PART DESCRIPTION	ORDER NO.	PKG. MARK
SSI 32R516		
4-Channel SOL	32R516-4CL	32R516-4CL
6-Channel PLCC	32R516-6CH	32R516-6CH
6-Channel SOL	32R516-6CL	32R516-6CL
8-Channel SOW	32R516-8CW	32R516-8CW
8-Channel SOL	32R516-8CL	32R516-8CL
SSI 32R516R		
4-Channel SOL	32R516R-4CL	32R516R-4CL
6-Channel PLCC	32R516R-6CH	32R516R-6CH
6-Channel SOL	32R516R-6CL	32R516R-6CL
8-Channel SOW	32R516R-8CW	32R516R-8CW
8-Channel SOL	32R516R-8CL	32R516R-8CL
SSI 32R516M		
6-Channel SOL	32R516M-6CL	32R516M-6CL
8-Channel SOW	32R516M-8CW	32R516M-8CW
8-Channel SOL	32R516M-8CL	32R516M-8CL
SSI 32R516RM		
6-Channel SOL	32R516RM-6CL	32R516RM-6CL
8-Channel SOW	32R516RM-8CW	32R516RM-8CW
8-Channel SOL	32R516RM-8CL	32R516RM-8CL

No responsibility is assumed by Silicon Systems for use of this product nor for any infringements of patents and trademarks or other rights of third parties resulting from its use. No license is granted under any patents, patent rights or trademarks of Silicon Systems. Silicon Systems reserves the right to make changes in specifications at any time without notice. Accordingly, the reader is cautioned to verify that the data sheet is current before placing orders.

Silicon Systems, Inc., 14351 Myford Road, Tustin, CA 92680 (714) 573-6000, FAX (714) 573-6914