

PNA4SxxM Series (PNA4S01M/4S03M/4S04M)

Bipolar Integrated Circuit with Photodetection Function

For infrared remote control systems

■ Features

- Surface-mounting type for reflow soldering
- Metal shieldless
- Space saved by miniaturization
- Ready for automatic mounting

■ Absolute Maximum Ratings (Ta = 25°C)

Parameter	Symbol	Ratings	Unit
Power supply voltage	V _{CC}	-0.5 to +7	V
Power dissipation	P _D	200	mW
Operating ambient temperature	T _{opr}	-20 to +60	°C
Storage temperature	T _{stg}	-30 to +70	°C

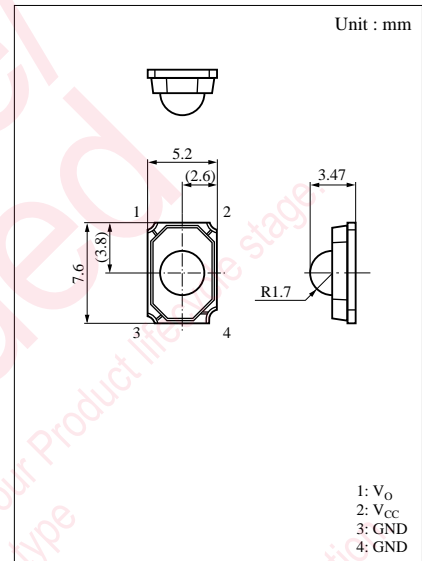

■ Main Characteristics (Ta = 25°C V_{CC} = 5V)

Parameter	Symbol	Conditions	min	typ	max	Unit
Operating supply voltage	V _{CC}		4.7	5.0	5.3	V
Current consumption	I _{CC}	No signal condition	1.8	2.4	3.0	mA
Maximum reception distance	L _{max} ^{*1}		5.0			m
Low-level output voltage	V _{OL} ^{*2}	L≤5.0m, 10L=400μA		0.35	0.5	V
High-level output voltage	V _{OH}	No signal condition	4.8	5.0	V _{CC}	V
Low-level pulse width	T _{WL} ^{*1}	L=5.0m, 16Pulse	200	400	600	μs
High-level pulse width	T _{WH} ^{*1}	L=5.0m, 16Pulse	200	400	600	μs
Carrier frequency	PNA4S01M	f ₀		36.7		kHz
	PNA4S03M			40.0		
	PNA4S04M			56.9		

^{*1} Fig.1 burst wave, L=L_{max}, 16 pulses

^{*2} Fig.2 continuous wave, L≤L_{max}

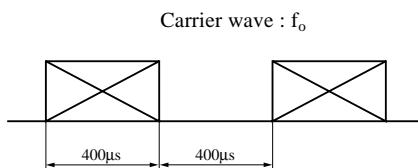

Fig.1

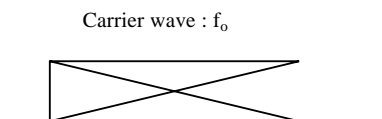
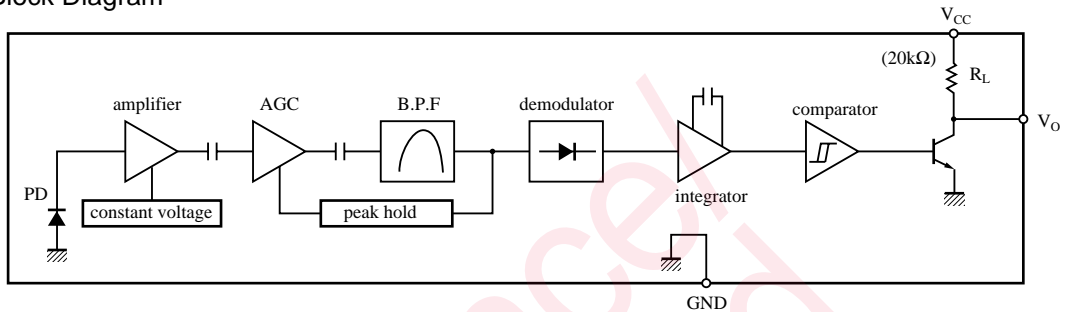
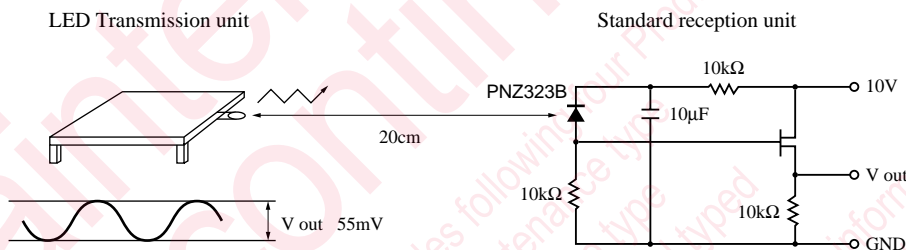

Fig.2

■ Block Diagram



■ Panasonic Transmitter Specifications



- The light output of the LED transmission unit is adjusted so that the transmission output (V out) of the standard reception unit will be 55 mV when the transmission waveform (duty = 50%) is output from the LED transmission unit. Here, infrared sensitivity (SIR) of PNZ323B is 0.53 μA when emission illuminance (H) is 12.45 $\mu\text{W}/\text{cm}^2$.
- The maximum reception distance under these specifications is an assurance that T_{WH} and T_{WL} values will be within the tolerance ranges when 16 consecutive pulses of an optical output equivalent to the maximum reception distance are transmitted by the above transmission unit (The maximum reception distance is measured in the dark without external disturbance noise.)

L max — Ta

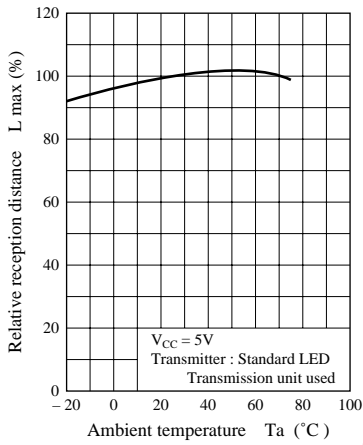

B.P.F frequency characteristics (PNA4S02M)*



Spectral sensitivity characteristics

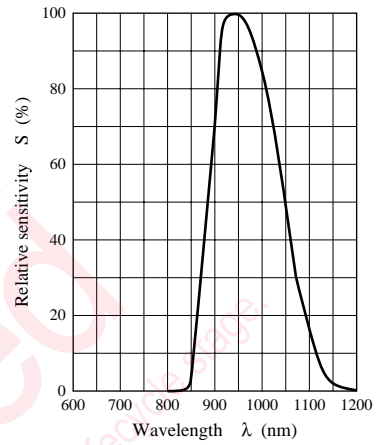

* The peaks for PNA4S01M, PNA4S08M are all f_0 .

Directivity characteristics

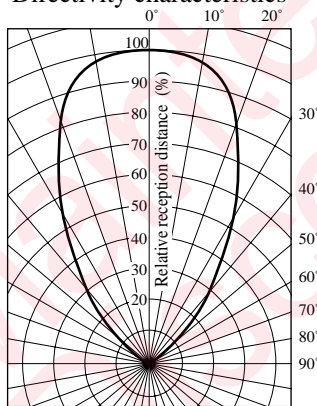

Maintenance/Discontinued includes following four Product life cycle types
 planned maintenance type
 maintenance type
 planned discontinued type
 discontinued type
 Please visit following URL about latest information.
<http://www.semicon.panasonic.co.jp/en/>

Request for your special attention and precautions in using the technical information and semiconductors described in this book

- (1) If any of the products or technical information described in this book is to be exported or provided to non-residents, the laws and regulations of the exporting country, especially, those with regard to security export control, must be observed.
- (2) The technical information described in this book is intended only to show the main characteristics and application circuit examples of the products, and no license is granted under any intellectual property right or other right owned by our company or any other company. Therefore, no responsibility is assumed by our company as to the infringement upon any such right owned by any other company which may arise as a result of the use of technical information described in this book.
- (3) The products described in this book are intended to be used for standard applications or general electronic equipment (such as office equipment, communications equipment, measuring instruments and household appliances).
Consult our sales staff in advance for information on the following applications:
 - Special applications (such as for airplanes, aerospace, automobiles, traffic control equipment, combustion equipment, life support systems and safety devices) in which exceptional quality and reliability are required, or if the failure or malfunction of the products may directly jeopardize life or harm the human body.
 - Any applications other than the standard applications intended.
- (4) The products and product specifications described in this book are subject to change without notice for modification and/or improvement. At the final stage of your design, purchasing, or use of the products, therefore, ask for the most up-to-date Product Standards in advance to make sure that the latest specifications satisfy your requirements.
- (5) When designing your equipment, comply with the range of absolute maximum rating and the guaranteed operating conditions (operating power supply voltage and operating environment etc.). Especially, please be careful not to exceed the range of absolute maximum rating on the transient state, such as power-on, power-off and mode-switching. Otherwise, we will not be liable for any defect which may arise later in your equipment.
 - Even when the products are used within the guaranteed values, take into the consideration of incidence of break down and failure mode, possible to occur to semiconductor products. Measures on the systems such as redundant design, arresting the spread of fire or preventing glitch are recommended in order to prevent physical injury, fire, social damages, for example, by using the products.
- (6) Comply with the instructions for use in order to prevent breakdown and characteristics change due to external factors (ESD, EOS, thermal stress and mechanical stress) at the time of handling, mounting or at customer's process. When using products for which damp-proof packing is required, satisfy the conditions, such as shelf life and the elapsed time since first opening the packages.
- (7) This book may be not reprinted or reproduced whether wholly or partially, without the prior written permission of Matsushita Electric Industrial Co., Ltd.