

TOSHIBA CMOS DIGITAL INTEGRATED CIRCUIT SILICON MONOLITHIC

# T6B23

## COLUMN DRIVER LSI FOR A DOT MATRIX LCD

The T6B23 is a column driver with 80 output channels for a dot matrix LCD.

The T6B23 realizes low power consumption using the CMOS Si-Gate process. The T6B23 has two types of data flow:

(1)  $O_1 \rightarrow O_{80}$ , (2)  $O_{80} \rightarrow O_1$ .

### FEATURES

- 80-output column driver
- Data input format
  - : ENABLE mode
  - : SHIFT mode
- Two types of data flow:
  - (1)  $O_1 \rightarrow O_{80}$
  - (2)  $O_{80} \rightarrow O_1$
- Low power consumption
- Logic voltage :  $5.0V \pm 10\%$
- LCD drive voltage :  $V_{DD} - 3.0V$  to  $V_{DD} - 11.0V$
- 100-pin plastic flat package

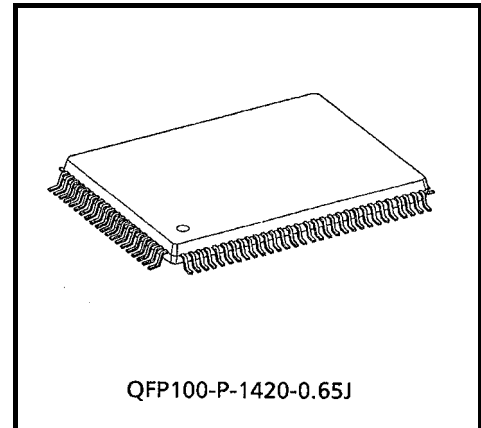

Weight : 1.6 g (typ.)

## PIN ASSIGNMENT

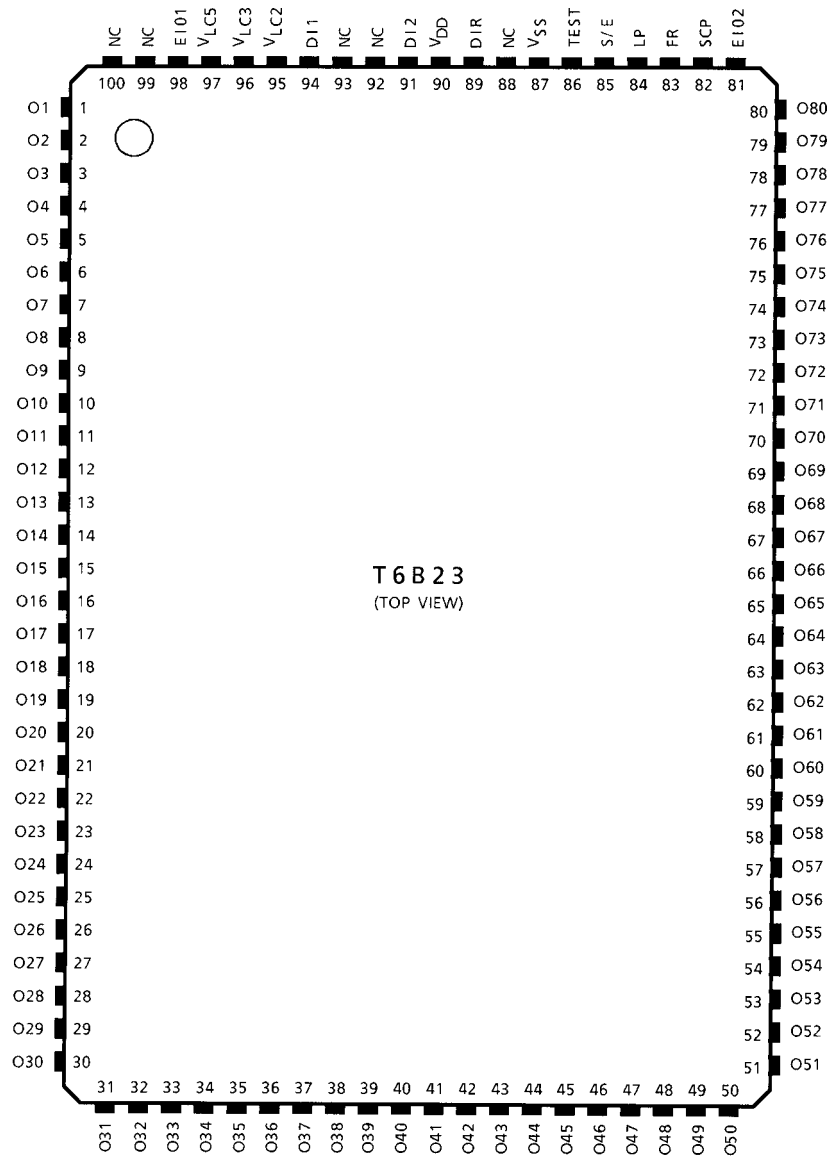

## BLOCK DIAGRAM

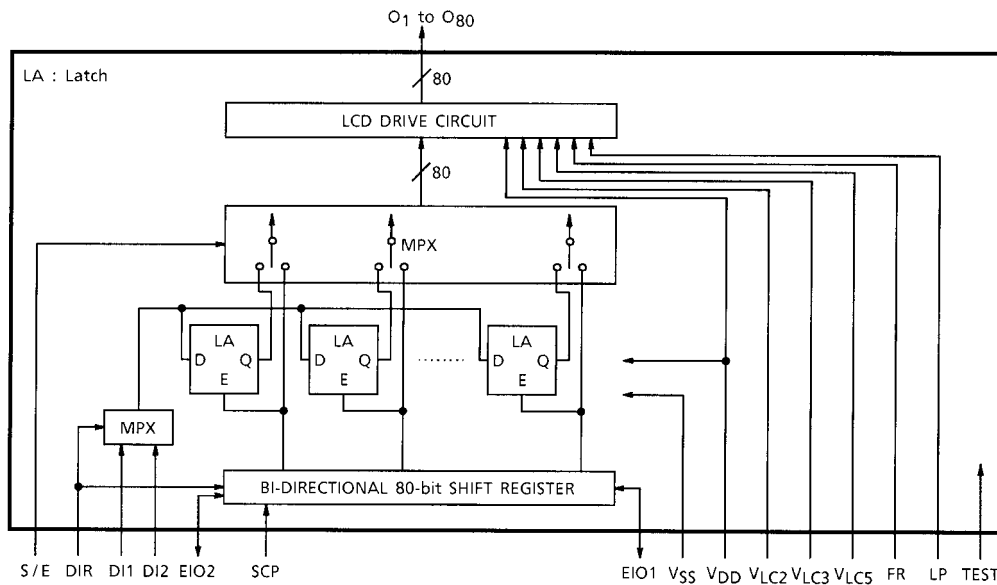

## PIN FUNCTIONS

PIN NAME	I / O	FUNCTIONS	LEVEL
O1 to O80	Output	LCD drive output	$V_{DD}$ to $V_{LC5}$
D11, D12	Input	Data signal input	$V_{DD}$ to $V_{SS}$
EIO1, EIO2	I / O	ENABLE I / O When S / E = H, this pin is for input.	
SCP	Input	(Shift Clock Pulse) Shift clock pulse input	
FR	Input	(Frame) Frame signal input	
LP	Input	(Latch Pulse) Latch pulse signal input	
S / E	Input	Extension driver select input	
DIR	Input	Input data flow direction select input	
TEST	Input	Test pin: usually connected to $V_{SS}$ .	
$V_{LC2, 3, 5}$	—	Power supply for LCD drive	
$V_{DD}$	—	Power supply (5V)	
$V_{SS}$	—	Power supply (0V)	

## FUNCTION OF DATA AND ENABLE PINS

S / E DIR	DI1	DI2	EIO1	EIO2	DATA FLOW	FIRST DATA	LAST DATA	MODE	
L	L	Open	DATA INPUT	ENABLE signal input	ENABLE signal output	$O_{80} \rightarrow O_1$	$O_1$	$O_{80}$	ENABLE
L	H	DATA INPUT	Open	ENABLE signal output	ENABLE signal input	$O_1 \rightarrow O_{80}$	$O_{80}$	$O_1$	
H	L	Open	Open	DATA INPUT	DATA OUTPUT	$O_1 \rightarrow O_{80}$	$O_{80}$	$O_1$	SHIFT
H	H	Open	Open	DATA OUTPUT	DATA INPUT	$O_{80} \rightarrow O_1$	$O_1$	$O_{80}$	

## TIMING DIAGRAM

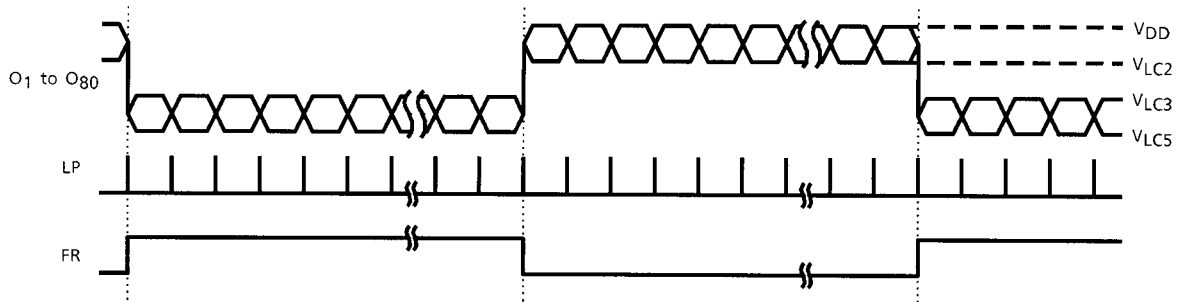

## ABSOLUTE MAXIMUM RATINGS (Ta = 25°C)

ITEM	SYMBOL	RATING	UNIT
Supply Voltage (1)	V <sub>DD</sub> (Note 1)	- 0.3 to 7.0	V
Supply Voltage (2)	V <sub>L</sub> C2, V <sub>L</sub> C3, V <sub>L</sub> C5 (Note1, 2)	V <sub>DD</sub> - 12.0 to V <sub>DD</sub> + 0.3	V
Input Voltage	V <sub>IN</sub> (Note 1)	- 0.3 to V <sub>DD</sub> + 0.3	V
Operating Temperature	T <sub>opr</sub>	- 20 to 75	°C
Storage Temperature	T <sub>stg</sub>	- 55 to 125	°C

Note 1: Referenced to V<sub>SS</sub> = 0 V

Note 2: Ensure that the following condition is always maintained.  
 $V_{DD} \geq V_{LC2} \geq V_{LC3} \geq V_{LC5}$

## ELECTRICAL CHARACTERISTICS

### DC CHARACTERISTICS

TEST CONDITIONS (Unless Otherwise Noted,  $V_{SS} = 0\text{ V}$ ,  $V_{DD} = 5.0\text{ V} \pm 10\%$ ,  $V_{LC5} = 0\text{ V}$ ,  $T_a = -20\text{ to }75^\circ\text{C}$ )

ITEM	SYMBOL	TEST CIR-CUIT	TEST CONDITION	MIN	TYP.	MAX	UNIT	PIN NAME	
Operating Voltage (1)	$V_{DD}$	—	—	4.5	5.0	5.5	V	$V_{DD}$	
Operating Voltage (2)	$V_{LC5}$	—	—	$V_{DD} - 11.0$	—	$V_{DD} - 3.0$	V	$V_{LC5}$	
Input Voltage	H Level	$V_{IH}$	—	$V_{DD} - 1.0$	—	$V_{DD}$	V	(*)	
	L Level	$V_{IL}$	—	0	—	1.0	V	(*)	
Output Voltage	H Level	$V_{OH}$	$I_{OH} = -0.4\text{ mA}$	$V_{DD} - 0.4$	—	$V_{DD}$	V	EIO1, EIO2	
	L Level	$V_{OL}$	$I_{Oh} = 0.4\text{ mA}$	0	—	0.4	V	EIO1, EIO2	
Output Resistance	$R_{COL}$	—	$I_d = \pm 50\mu\text{A}$	—	—	30	$k\Omega$	$O_1$ to $O_{80}$	
Operating Frequency	$f_{scp}$	—	$T_a = -20\text{ to }75^\circ\text{C}$	—	—	400	kHz	SCP	
Current Consumption	$I_{SS}$	—	$V_{DD} = 5.0\text{ V}$ $V_{LC2} = 3.0\text{ V}$ $V_{LC3} = 2.0\text{ V}$ $V_{LC5} = 0.0\text{ V}$ $f_{FR} = 39\text{ Hz}$ $f_{SCP} = 250\text{ kHz}$ $O_1$ to $O_{80}$ :No Load	Binary Data Input	—	—	1.0	mA	$V_{SS}$
				Input Data : LOW Constant	—	—	0.4	mA	

\*: SCP, LP, FR, EIO1, EIO2, DI1, DI2, DIR, S / E, TEST

## AC CHARACTERISTICS

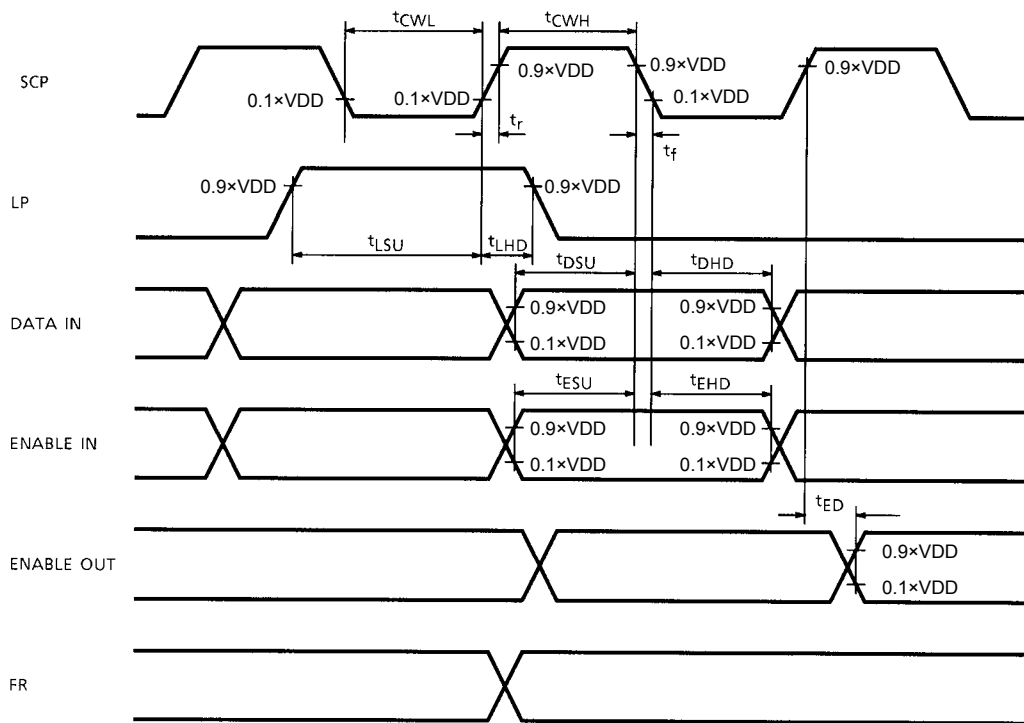

**TEST CONDITIONS** (Unless Otherwise Noted,  $V_{SS} = 0\text{ V}$ ,  $V_{DD} = 5\text{ V} \pm 10\%$ ,  $V_{LC5} = 0\text{ V}$ ,  $T_a = -20\text{ to }75^\circ\text{C}$ )

ITEM	SYMBOL	MIN	MAX	UNIT
Operating Frequency	$f_{SCP}$	—	400	KHz
SCP Pulse Width	$t_{CWL}, t_{CWH}$	800	—	ns
SCP Rise / Fall Time	$t_r, t_f$	—	200	ns
LP Set-up Time	$t_{LSU}$	500	—	ns
LP Hold Time	$t_{LHD}$	—	10	ns
Data Set-up Time	$t_{DSU}$ (Note 1)	300	—	ns
Data Hold Time	$t_{DHD}$ (Note 1)	300	—	ns
Enable Set-up Time	$t_{ESU}$ (Note 2)	300	—	ns
Enable Hold Time	$t_{EHD}$ (Note 2)	300	—	ns
Enable Delay Time	$t_{ED}$ (Note 3)	—	500	ns

### LOAD CIRCUIT

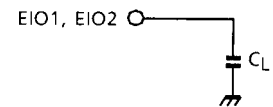

$C_L = 50\text{pF}$   
(including wiring capacitance)

Note 1: Applies to DI1 and DI2.

Note 2: Applies to EIO1 and EIO2.

Note 3: With load circuit connected

## APPLICATION CIRCUIT

(a) S / E = L (ENABLE mode)

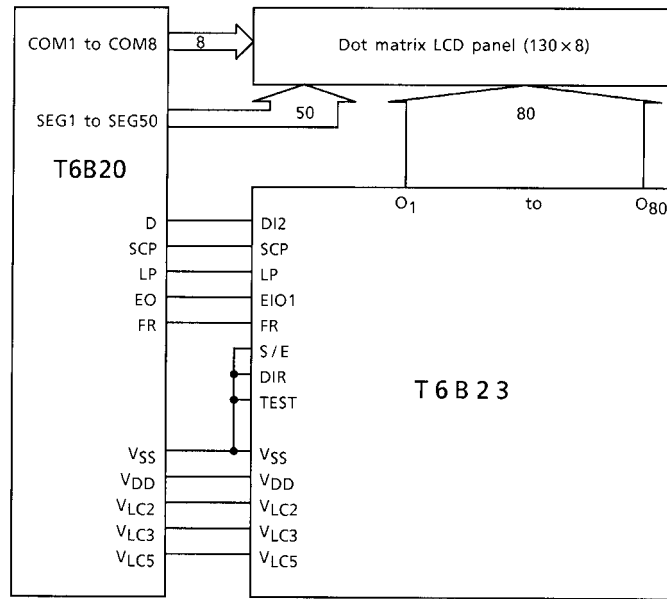

(b) S / E = H (SHIFT mode)

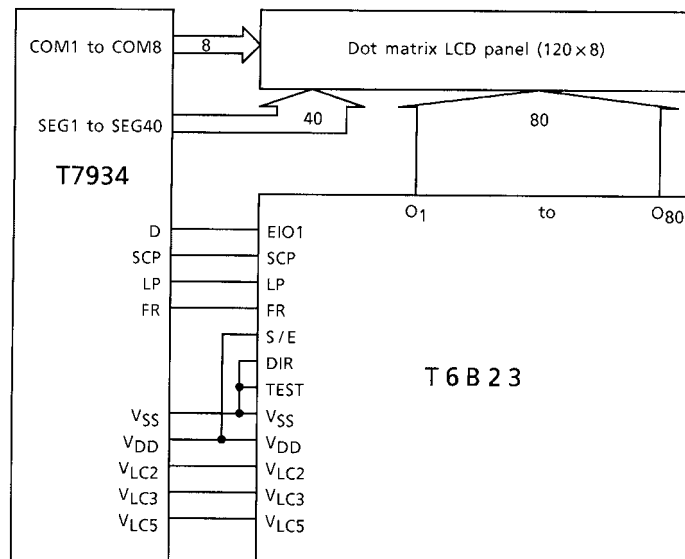

## Package Dimensions

QFP100-P-1420-0.65J

Unit: mm

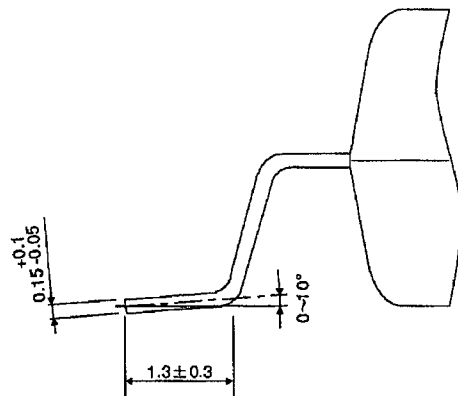
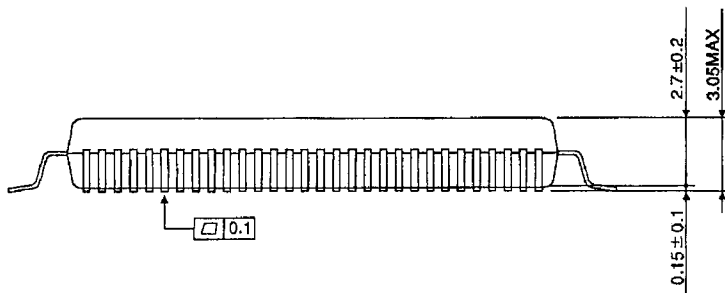
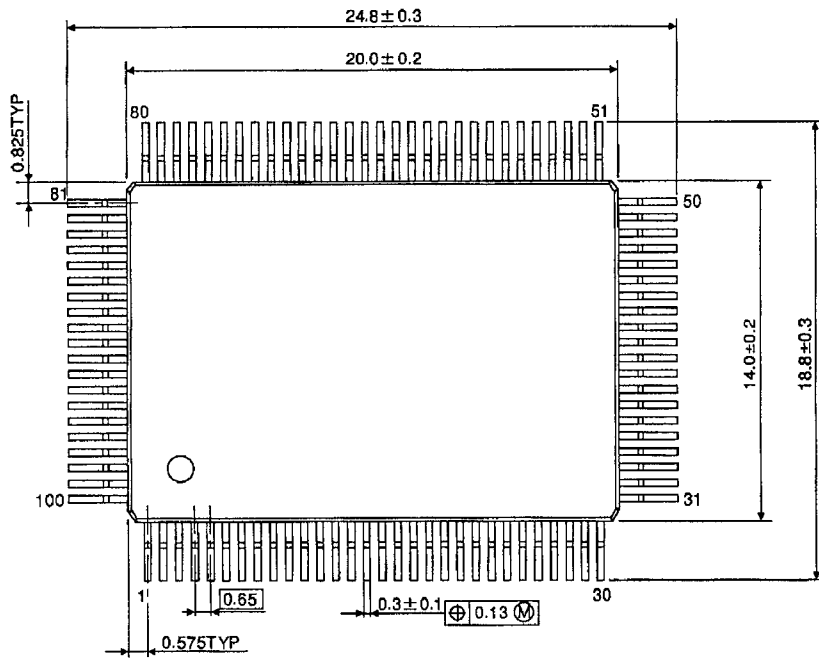

Weight : 1.6 g (Typ.)

**RESTRICTIONS ON PRODUCT USE**

000707EBA

- TOSHIBA is continually working to improve the quality and reliability of its products. Nevertheless, semiconductor devices in general can malfunction or fail due to their inherent electrical sensitivity and vulnerability to physical stress. It is the responsibility of the buyer, when utilizing TOSHIBA products, to comply with the standards of safety in making a safe design for the entire system, and to avoid situations in which a malfunction or failure of such TOSHIBA products could cause loss of human life, bodily injury or damage to property.  
In developing your designs, please ensure that TOSHIBA products are used within specified operating ranges as set forth in the most recent TOSHIBA products specifications. Also, please keep in mind the precautions and conditions set forth in the "Handling Guide for Semiconductor Devices," or "TOSHIBA Semiconductor Reliability Handbook" etc..
- The TOSHIBA products listed in this document are intended for usage in general electronics applications (computer, personal equipment, office equipment, measuring equipment, industrial robotics, domestic appliances, etc.). These TOSHIBA products are neither intended nor warranted for usage in equipment that requires extraordinarily high quality and/or reliability or a malfunction or failure of which may cause loss of human life or bodily injury ("Unintended Usage"). Unintended Usage include atomic energy control instruments, airplane or spaceship instruments, transportation instruments, traffic signal instruments, combustion control instruments, medical instruments, all types of safety devices, etc.. Unintended Usage of TOSHIBA products listed in this document shall be made at the customer's own risk.
- The products described in this document are subject to the foreign exchange and foreign trade laws.
- The information contained herein is presented only as a guide for the applications of our products. No responsibility is assumed by TOSHIBA CORPORATION for any infringements of intellectual property or other rights of the third parties which may result from its use. No license is granted by implication or otherwise under any intellectual property or other rights of TOSHIBA CORPORATION or others.
- The information contained herein is subject to change without notice.