

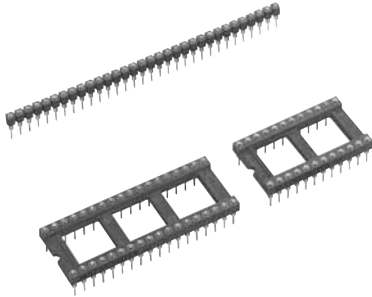

HIGH RELIABILITY IC SOCKET WITH ROUND PIN

ROUND PIN TYPE IC SOCKETS



FEATURES

1. With advanced design method of the frame, stress transmission from the PC board is greatly reduced.
2. This is a high reliability IC socket with round pin external contacts constructed with 4 point internal contacts. Because of the gold plating on all surfaces, the 4 point contact construction offers superior resistance to vibration, shock, and environmental conditions, resulting in high reliability.
3. Terminal shape prevents entrance of solder flux. Because of the round pin construction and sufficient distance being provided between the PC board mounting surface and the frame, flux cannot rise up into the contact section.

CONSTRUCTION OF CONTACT

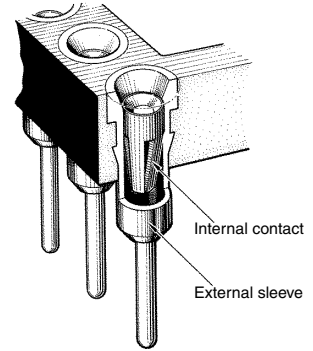

Compliance with RoHS Directive

ORDERING INFORMATION

AXS 1 0 [] [] [] []

10: Round PIN type IC sockets

<No. of contacts (2 digits)>

08: 8 contacts	14: 14 contacts	16: 16 contacts	18: 18 contacts
20: 20 contacts	22: 22 contacts	24: 24 contacts	28: 28 contacts
32: 32 contacts	36: 36 contacts	40: 40 contacts	48: 48 contacts
64: 64 contacts			

<Terminal layout and shape>

1: DIL terminal layout, solder DIP terminal
 2: SIL terminal layout, solder DIP terminal
 7: DIL terminal layout, solder DIP terminal (24 contacts: row pitch is 7.62 mm)

<Surface treatment (Internal contact/External sleeve)>

1: Au plating 0.25μm/Sn plating
 3: Au plating 0.76μm/Sn plating
 7: Au plating 0.76μm/Au plating
 9: Sn plating/Sn plating



PRODUCT TYPES

1. Solder dip terminal type

Item		Economical type (Extremely resistant to fretting with IC)	General-purpose type (Extremely resistant to fretting with IC)	High-reliability type (Contact resistance is stable even if left unadhered for extended periods.)	Testing use	Packaging	
External sleeve		Sn plating			Au plating		
Internal contact		Sn plating	Au plating (0.25μm)	Au plating (0.76μm)	Au plating (0.76μm)		
Type	No. of contacts	Part No.	Part No.	Part No.	Part No.	Inner carton (Stick)	Outer carton
DIL	8	AXS100819	AXS100811	AXS100813	AXS100817	50 pcs.	300 pcs.
	14	AXS101419	AXS101411	AXS101413	AXS101417	25 pcs.	300 pcs.
	16	AXS101619	AXS101611	AXS101613	AXS101617	25 pcs.	300 pcs.
	18	AXS101819	AXS101811	AXS101813	AXS101817	20 pcs.	300 pcs.
	20	AXS102019	AXS102011	AXS102013	AXS102017	20 pcs.	300 pcs.
	22	AXS102219	AXS102211	AXS102213	AXS102217	15 pcs.	300 pcs.
	24*1	AXS102419	AXS102411	AXS102413	AXS102417	15 pcs.	300 pcs.
	24*2	AXS102479	AXS102471	AXS102473	AXS102477	15 pcs.	300 pcs.
	28	AXS102819	AXS102811	AXS102813	AXS102817	15 pcs.	300 pcs.
	32	AXS103219	AXS103211	AXS103213	AXS103217	10 pcs.	300 pcs.
	36	AXS103619	AXS103611	AXS103613	AXS103617	10 pcs.	300 pcs.
	40	AXS104019	AXS104011	AXS104013	AXS104017	10 pcs.	300 pcs.
	48	AXS104819	AXS104811	AXS104813	AXS104817	8 pcs.	200 pcs.
64	AXS106419	AXS106411	AXS106413	AXS106417	5 pcs.	100 pcs.	
SIL	32	AXS103229	AXS103221	AXS103223	AXS103227	10 pcs.	100 pcs.

*1 Pitch: 15.24mm

*2 Pitch: 7.62mm

(Note) All are stick packaged.

- SIL type produced after order products: Supports up to 32 contacts. (Minimum order is 1,000 pieces)

SPECIFICATIONS

1. Characteristics

Item		Specifications	Condition
Electrical characteristics	Rated current	1A	
	Breakdown voltage	1,000V AC for 1 min.	Detection current: 1mA
	Insulation resistance	Min. 1,000MΩ	Using 500V DC megger
	Contact resistance	Max. 20mΩ	Measured based on the HP4338B measurement method of JIS C 5402
	Electrostatic capacitance	Max. 2pF	at 1kHz
Mechanical characteristics	Vibration resistance	10 to 2,000Hz, 147m/s ² {15G}	After carrying current (Max. 100mA) during the test, no interruption of current longer than 1μs does not occur.
	Shock resistance	980m/s ² {100G}	After carrying current (Max. 100mA) during the test, no interruption of current longer than 1μs does not occur.
	Insertion force of single contact	Max. 3.33N {340gf}	Measured by a 0.41mm dia. steel gauge with a surface roughness of 0.1 s.
	Pull-out force of single contact	Min. 0.392N {40gf}	Measured by a 0.41mm dia. steel gauge with a surface roughness of 0.1 s.
	Insertion and removal life	Min. 100 times	With usage of applicable leads
Applicable leads		Square lead: at 0.5±0.1×0.25±0.05 Round lead: Diameter 0.4 to 0.53mm	
Environmental resistance	H ₂ S gas	Contact resistance after test: Max. 20mΩ	After 96 hours of exposure to humidity 75 to 80% R.H., temperature 40°C±2°C, concentration 3±1 ppm
	SO ₂ gas	Contact resistance after test: Max. 20mΩ	After 48 hours of exposure to humidity 90 to 95% R.H., temperature 40°C±2°C, concentration 10±3 ppm
	Humidity	Contact resistance after test: Max. 20mΩ Insulation resistance after test: Min. 300MΩ	After 96 hours of exposure to humidity 90 to 95% R.H., temperature 40°C±2°C
	Thermal shock resistance	Contact resistance after test: Max. 20mΩ Insulation resistance after test: Min. 300MΩ	Low temperature: -55°C (30 min.) 1 cycle High temperature: +125°C (30 min.) 1 cycle No. of cycles: 5 cycles
	Ambient temperature	Au plating: -55°C to +125°C Sn plating: -55°C to +85°C (No freezing at low temperature)	
	Soldering temperature	350°C: within 3 sec. 260°C: with 10 sec.	

2. Materials and surface treatment

Part name	Material	Surface treatment
Frame	Glass-reinforced PBT (UL94V-0)	—
External sleeve	Brass	Ni plating on base, Sn plating on surface or Ni plating on base, Au plating on surface
Internal contact	Beryllium copper	Ni plating on base, Sn plating on surface Ni plating on base, Au plating on surface (0.25μm) Ni plating on base, Au plating on surface (0.76μm)



DIMENSIONS (Unit: mm)

The CAD data of the products with a **CAD Data** mark can be downloaded from: <http://panasonic-electric-works.net/ac>

• DIL solder-DIP terminal type

CAD Data

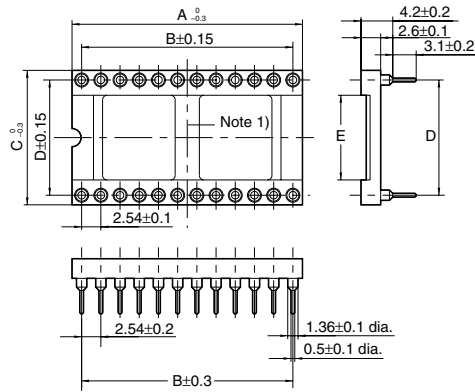

Recommended PC board pattern (BOTTOM VIEW)

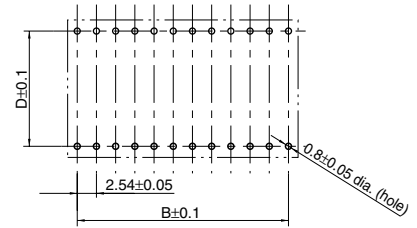

Note) Rib is not provided for 8, 14 and 16 contacts;
1 rib is provided for 18, 20, 22, 24 and 28 contacts; 2 ribs are provided for 32, 36, 40 and 48 contacts; 4 ribs are provided for 64 contacts.

Dimension table (mm)

No. of contacts	A	B	C	D	E
8	10.16	7.62	10.16	7.62	4.3
14	17.78	15.24	10.16	7.62	4.3
16	20.32	17.78	10.16	7.62	4.3
18	22.86	20.32	10.16	7.62	4.3
20	25.4	22.86	10.16	7.62	4.3
22	27.94	25.4	12.7	10.16	6.4
24*1	30.48	27.94	17.78	15.24	11.2
24*2	30.48	27.94	10.16	7.62	4.3
28	35.56	33.02	17.78	15.24	11.2
32	40.64	38.1	17.78	15.24	11.2
36	45.72	43.18	17.78	15.24	11.2
40	50.8	48.26	17.78	15.24	11.2
48	60.96	58.42	17.78	15.24	11.2
64	81.28	78.74	25.4	22.86	17.8

*1 Pitch: 15.24mm

*2 Pitch: 7.62mm

• Rib layout (for DIL type)

8 to 16 contacts

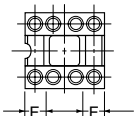

Dimension table (mm)

No. of contacts	F
8	2.9
14	3.0
16	3.1

32 to 48 contacts

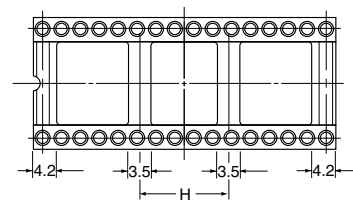

Dimension table (mm)

No. of contacts	H
32	11.5
36	13.5
40	15.5
48	15.5

18 to 28 contacts

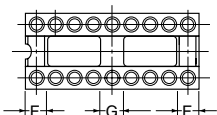

Dimension table (mm)

No. of contacts	F	G
18	3.5	3.0
20	3.5	3.0
22	3.7	3.0
24*1	4.0	3.2
24*2	4.2	3.0
28	4.0	3.2

*1 Pitch: 15.24mm

*2 Pitch: 7.62mm

64 contacts

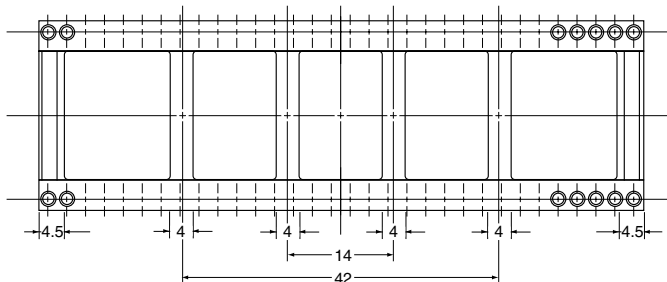

General tolerance: ±0.3



• SIL solder-DIP type (32 contacts)

CAD Data

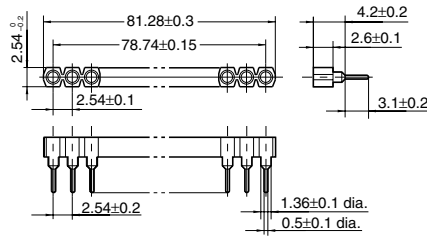
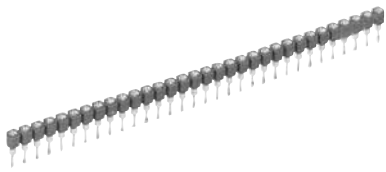

Recommended PC board pattern
(BOTTOM VIEW)

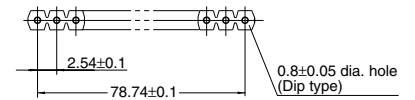

• Terminal (Common for DIL and SIL terminals)

Dip terminal

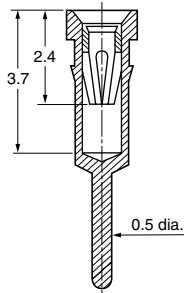

NOTES

1. Do not use for inserting of leads other than of applicable dimension. There is the possibility of distorting the internal contacts.
2. Because repeated flexing of the terminals can lead to the breakage of the terminal, care should be taken.
3. Soldering should be done under the following conditions.
 260°C : Within 10 seconds soldering bath
 350°C : Within 3 seconds soldering iron
4. Flux of the non-corroding rosin type should be used.
5. Liquid flux of minimum chemical action type alcohol can be used.
6. Sufficient care should be taken to prevent flux from entering the upper surface of the IC socket.
7. For mounting and removing the IC, a special tool for insertion and removal of IC's should be used.

For other details, please verify with the product specification sheets.