

T-51-10-12



TC8702  
TC8704  
TC8705

2

**BINARY OUTPUT ANALOG-TO-DIGITAL CONVERTERS**

**FEATURES**

- High Accuracy — Up to 12-Bit Resolution With  $\pm 1/2$  LSB Error
- Monotonic Performance — No Missing Codes
- Monolithic CMOS Construction Gives Low Power Dissipation ..... 20 mW Typ
- Contains All Required Active Elements — Needs Only Passive Support Components, Reference Voltage, and Dual-Power Supply
- High Stability Over Full Temperature Range
  - Gain Temperature Coefficient ...  $<25$  ppm/ $^{\circ}$ C Typ
  - Zero Drift .....  $<30$   $\mu$ V/ $^{\circ}$ C Typ
  - Differential Nonlinearity Drift .....  $<25$  ppm/ $^{\circ}$ C Typ
- Latched Parallel Binary Outputs
- Three-State, Bus Compatible Outputs (TC8704 and TC8705)
- LPTTL, 74LS, CMOS Compatible Outputs and Control Inputs
- Strobed or Free-Running Conversion
- Infinite Input Range — Any Positive Voltage Can Be Applied Via a Scaling Resistor

**TEST CIRCUIT**

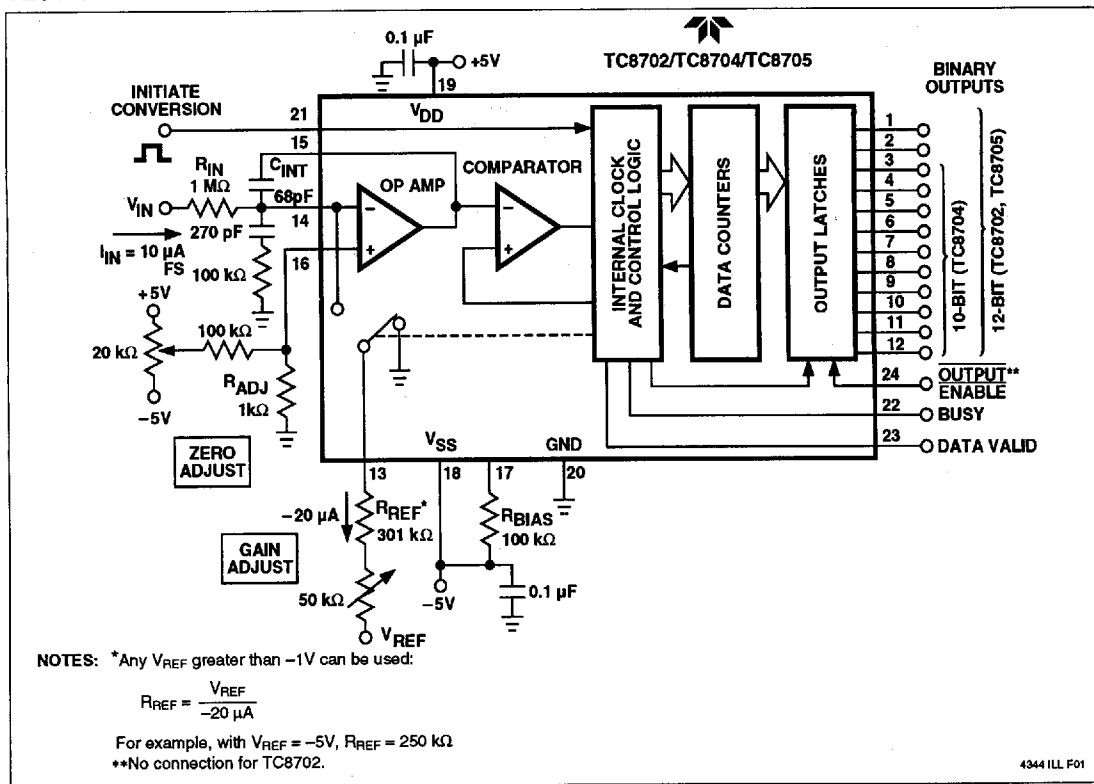

T-51-10-12

## BINARY OUTPUT ANALOG-TO-DIGITAL CONVERTERS

TC8702  
TC8704  
TC8705

### GENERAL DESCRIPTION

The TC8702/TC8704/TC8705 are 10- and 12-bit monolithic CMOS analog-to-digital converters (ADCs). Fully self-contained in a single 24-pin dual-in-line package, each converter requires only passive support components, reference and power supplies.

Conversion is performed by an incremental charge balancing technique which has inherently high accuracy, linearity and noise immunity. An amplifier integrates the sum of the unknown analog current and pulses of a reference current, and the number of pulses (charge increments) needed to maintain the amplifier summing junction near zero are counted. At the end of conversion, the total count is latched into the digital outputs as a 10- or 12-bit binary word.

The TC8704/8705 features a three-state output bus controlled by an output enable input. The output enable control switches to a high impedance or off-state when held high. The off-state allows bus-organized output connections. On the TC8702, outputs are always active.

### PIN CONFIGURATION

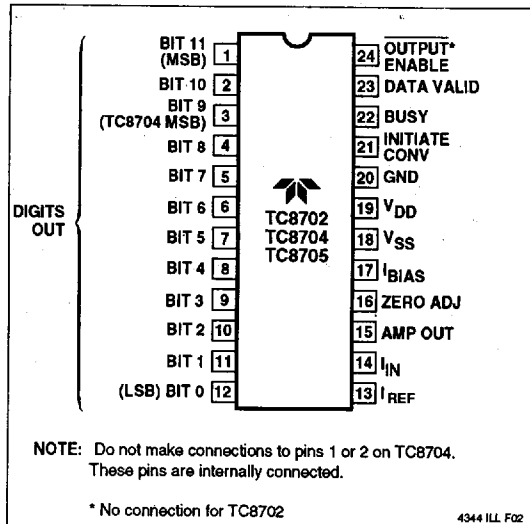

### ORDERING INFORMATION

Part No.	Previous Part No.	Resolution	Conversion Time (ms)	Package	Temperature Range
TC8702EHG	TSC8702CN	12-Bit	20	24-Pin CerDIP	-40°C to +85°C
TC8702MJG	TSC8702CN	12-Bit	20	24-Pin CerDIP	-55°C to +125°C
TC8704CPG	TSC8704CJ	10-Bit	5	24-Pin Plastic DIP	0°C to +70°C
TC8704EJG	TSC8704CL	10-Bit	5	24-Pin CerDIP	-40°C to +85°C
TC8704MJG	TSC8704BL	10-Bit	5	24-Pin CerDIP	-55°C to +125°C
TC8705CPG	TSC8705CJ	12-Bit	20	24-Pin Plastic DIP	0°C to +70°C
TC8705EHG	TSC8705CL	12-Bit	20	24-Pin CerDIP	-40°C to +85°C
TC8705MHG	TSC8705BL	12-Bit	20	24-Pin CerDIP	-55°C to +125°C

T-51-10-12

## BINARY OUTPUT ANALOG-TO-DIGITAL CONVERTERS

TC8702  
TC8704  
TC8705

2

### ABSOLUTE MAXIMUM RATINGS

$V_{DD} - V_{SS}$ .....	+18V
$I_{IN}$ .....	$\pm 10$ mA
$I_{REF}$ .....	$\pm 10$ mA
Digital Input Voltage .....	-0.3V to $V_{DD} + 0.3V$
Operating $V_{DD}$ and $V_{SS}$ Range .....	+3.5V to +7V
Storage Temperature Range .....	-65°C to +150°C
Operating Temperature Range	
CPG .....	0°C to +70°C
EJG .....	-40°C to +85°C
MJG, MHG .....	-55°C to +125°C

Package Dissipation .....	500 mW
Lead Temperature (Soldering, 10 sec) .....	+300°C

Static-sensitive device. Unused devices must be stored in conductive material. Protect devices from static discharge and static fields. Stresses above those listed under "Absolute Maximum Ratings" may cause permanent damage to the device. These are stress ratings only and functional operation of the device at these or any other conditions above those indicated in the operation sections of the specifications is not implied. Exposure to absolute maximum rating conditions for extended periods may affect device reliability.

**ELECTRICAL CHARACTERISTICS:**  $V_{DD} = +5V$ ,  $V_{SS} = -5V$ ,  $V_{GND} = 0$ ,  $V_{REF} = -6.4V$ ,  $R_{BIAS} = 100$  k $\Omega$ , test circuit shown, unless otherwise specified.  $T_A = +25^\circ C$  unless full temperature range is specified (-55°C to +125°C for MJG and MHG packages, -40°C to +85°C for EJG package, 0°C to +70°C for CPG package).

Parameter	Test Conditions	Definition	Min	Typ	CPE/EJ Max	MJ/MH Max	Unit
<b>Accuracy</b>							
Resolution Accuracy							
TC8704		Binary Word Length of Digital Output	10	—	—	—	Bits
TC8702/TC8705			12	—	—	—	Bits
Relative Accuracy		Output Deviation From Straight Line Between Normalized Zero and Full-Scale Input (TC8705CPG Only)	—	$\pm 1/4$	$\pm 1/2$	$\pm 1/2$	LSB
Differential Nonlinearity		Deviation From 1 LSB Between Transition Points	—	$\pm 1/4$	$\pm 1/2$	$\pm 1/2$	LSB
Differential Nonlinearity Temperature Drift	Full Temperature Range	Variation in Differential Nonlinearity Due to Temperature Change	—	$\pm 2.5$	$\pm 5$	$\pm 5$	ppm/°C
Gain Variance		Variation From Exact A (Compensate by Trimming $R_{IN}$ or $R_{REF}$ )	—	$\pm 2$	$\pm 5$	$\pm 5$	% of Nominal
Gain Temperature Drift	Full Temperature Range	Variation in A Due to Temperature Change	—	$\pm 25$	$\pm 75$	$\pm 80$	ppm/°C
Zero Offset	$I_{IN} = 0$ , $C_{INT} = 68$ pF, $R_{ADJ} = 1$ k $\Omega$ (See Test Circuit)	Correction at Zero Adjust to Give Zero Output When Input is Zero	—	$\pm 10$	$\pm 50$	$\pm 50$	mV
Zero Temperature Drift	Full Temperature Range	Variation in Zero Offset Due to Temperature Change	—	$\pm 3$	$\pm 5$	$\pm 8$	ppm/°C
<b>Analog Input (See Note)</b>							
$I_{IN}$ Full Scale		Full-Scale Analog Input Current to Achieve Specified Accuracy	—	10	—	—	$\mu A$
$I_{REF}$		Reference Current Input to Achieve Specified Accuracy	—	-20	—	—	$\mu A$
<b>Digital Input</b>							
$V_{IN}^{(1)}$	Full Temperature Range	Logic "1" Input Threshold for Initiate Conversion Input	3.5	—	—	—	V
$V_{IN}^{(0)}$	Full Temperature Range	Logic "0" Input Threshold for Initiate Conversion Input	—	—	1.5	1.5	V

T-51-10-12

## BINARY OUTPUT ANALOG-TO-DIGITAL CONVERTERS

**TC8702**  
**TC8704**  
**TC8705**

### ELECTRICAL CHARACTERISTICS (Cont.)

Parameter	Test Conditions	Definition	Min	Typ	CP/EJ Max	MJ/MH Max	Unit
<b>Propagation Delay</b>							
Output Enable (TC8704, TC8705)	$C_L = 100 \text{ pF}$ , $R_L = 1 \text{ k}\Omega$	$t_{PLH}$ , $t_{PHL}$	—	500	—	1000	ns
<b>Digital Output</b>							
$I_{O(OFF)}$ (TC8704, TC8705)	$OE = 3.5V$ $0.4V < V_C < 2.4V$	Off-State Output Current	—	0.1	$\pm 10$	$\pm 10$	$\mu A$
$V_{OUT}^{(1)}$	Full Temperature Range, $I_{OUT} = -10 \mu A$ $I_{OUT} = -500 \mu A$	Logic "1" Output Voltage for Digits Out, Busy, and Data Valid Outputs	4.5 2.4	— —	— —	— —	V V
$V_{OUT}^{(0)}$	Full Temperature Range, $V_{DD} = 4.75V$ $I_{OUT} = 500 \mu A$	Logic "0" Output Voltage for Digits Out, Busy, and Data Valid Outputs	—	—	0.4	0.4	V
<b>Dynamic</b>							
Conversion Time TC8704 TC8702, TC8705	Full Temperature Range	Time Required to Perform One Complete A/D Conversion	— —	5 20	6 24	6 24	ms ms
Conversion Rate in Free-Run Mode TC8704 TC8702, TC8705	$V_{INT CONV} = +5V$		167 42	200 50	— —	— —	sec
Minimum Pulse Width for Initiate Conversion	Full Temperature Range		500	—	—	—	ns
<b>Supply Current</b>							
$I_{DD}$ Quiescent J/H Packages P Package	Full Temperature Range, $V_{INT CONV} = 0V$	Current Required From Positive Supply During Operation	— —	1.4 1.4	2.5 5	3.5 —	mA mA
$I_{SS}$ Quiescent J/H Packages P Package	Full Temperature Range, $V_{INT CONV} = 0V$	Current Required From Negative Supply During Operation	— —	-1.6 -1.6	-2.5 -5	-3.5 —	mA mA
Supply Sensitivity	$V_{DD} \pm 1V$ , $V_{SS} \pm 1V$	Change in Full-Scale Gain vs Supply Voltage Change	—	$\pm 0.5$	$\pm 1$	$\pm 1$	%/V
	$I_{VDD1} = I_{VSS1} =$ $5V \pm 1V$	Change in full-Scale Gain vs Supply Voltage Change for Tracking Supplies	—	$\pm 0.05$	$\pm 0.1$	$\pm 0.1$	%/V

**NOTE:**  $I_{IN}$  and  $I_{REF}$  pins connect to the summing junction of an operational amplifier. Voltage sources cannot be attached directly but must be buffered by external resistors. See "Test Circuit."

T-51-10-12

## BINARY OUTPUT ANALOG-TO-DIGITAL CONVERTERS

TC8702  
TC8704  
TC8705

2

### TIMING DIAGRAMS

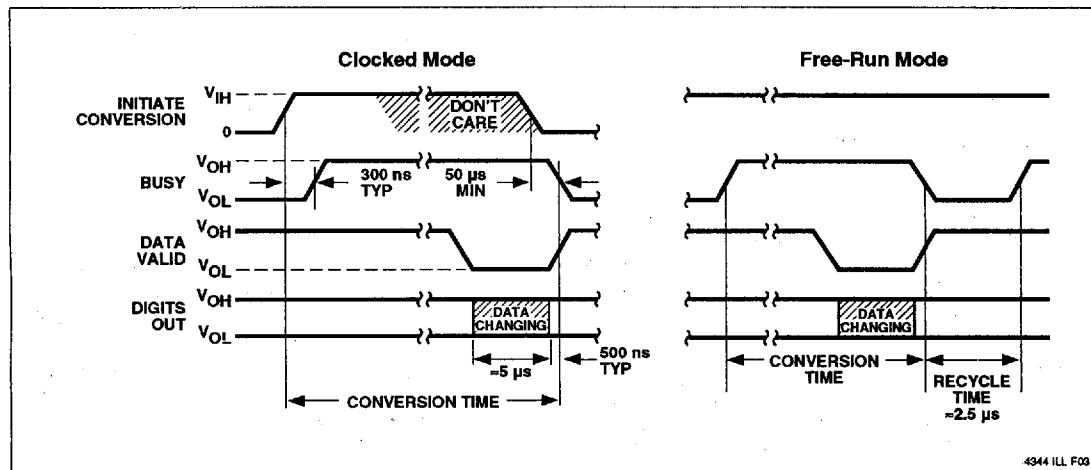

### CIRCUIT DESCRIPTION

During conversion, the sum of a continuous current ( $I_{IN}$ ) and pulses of a reference current ( $I_{REF}$ ) is integrated for a fixed number of clock periods.  $I_{IN}$  is proportional to the analog voltage;  $I_{REF}$  is switched in for exactly one clock period just frequently enough to maintain the output of the integrator near zero. Thus, the charge from the continuous  $I_{IN}$  is balanced against the pulses of  $I_{REF}$ . The total number of  $I_{REF}$  pulses needed during the conversion period to maintain the charge balance is counted, and the result (in binary) is latched into the outputs at the end of the conversion.

The converter contains two counters and a clock, in addition to an operational amplifier, comparator, latching output buffers, and housekeeping logic. One counter is a clock counter which starts counting clock pulses after a reset pulse; when the required count is reached, the clock counter generates a pulse to start the end-of-conversion routine. The other counter is a data counter, which is reset synchronously with the clock counter and counts the number of times  $I_{REF}$  is switched into the summing input of the amplifier during the period defined by the clock counter.

When the initiate conversion input is strobed with a positive signal, the busy line latches high and a 10  $\mu$ s (times given are approximate) start-up cycle begins. The integrating capacitor is discharged and both counters are reset during this start-up period. Conversion begins at the end of the reset pulse and ends with a pulse generated either by the clock counter or by an overflow condition in the data counter. This pulse disables further inputs into both counters and triggers a 10  $\mu$ s shutdown cycle. During the shutdown cycle, data valid goes low for 5  $\mu$ s. This

binary sequence is shown in the timing diagrams. Busy is true high and, when the circuit is busy, initiate conversion has no effect and may be high or low. Data valid is also true high. The data from a conversion remains valid for as long as power is applied to the circuit or until data valid falls at the end of a subsequent conversion, at which time the output data is updated to reflect the latest conversion.

### PIN FUNCTIONS

#### Initiate Conversion Input

Accepts CMOS and most +5V logic inputs. Applying a logic "1" to the initiate conversion pin initiates the A/D conversion cycle. Once conversion has been initiated, the cycle cannot be interrupted, and the initiate conversion pin is disabled until conversion is complete. Two modes of operation are permitted: clocked or free-running. For clocked operation, the initiate conversion input is held at logic "0" for standby and taken to logic "1" when a conversion is desired. For free-running operation, the initiate conversion pin is connected to  $V_{DD}$  or similar permanent logic "1" voltage.

#### Busy Output

A digital status output which is compatible with CMOS logic and low-power TTL (can sink and source 500  $\mu$ A). A logic "1" output on the busy pin indicates a conversion cycle is in process. A logic "1" to logic "0" transition indicates conversion is complete and the result has been latched at the digit out pins. A logic "0" to logic "1" transition indicates a new conversion cycle has been initiated. If the

T-51-10-12

## BINARY OUTPUT ANALOG-TO-DIGITAL CONVERTERS

TC8702  
TC8704  
TC8705

device is operating in the free-running mode, the busy output will remain low for approximately 2.5  $\mu$ s, marking the completion and initiation of consecutive conversion cycles.

### Data Valid Output

A digital status which is compatible with CMOS logic and low-power TTL (can sink and source 50  $\mu$ A). A logic "1" output at the data valid pin indicates the digits out pins are latched with the result of the last conversion cycle. The data valid output goes to logic "0" approximately 5  $\mu$ s before the completion of a conversion cycle. During this 5  $\mu$ s interval new data is being transferred to the digits out pins, and the digits out are not valid.

### Digits Out

The binary digit outputs (Bit 0 . . . Bit 11) which are the result of the A/D conversion. These outputs are CMOS logic and low-power TTL compatible.

## APPLICATIONS INFORMATION

### Input/Output Relationships

The analog input voltage ( $V_{IN}$ ) is related to the output by the transfer equation:

$$\text{Digital counts} = \frac{V_{IN} \cdot A \cdot R_{REF}}{R_{IN} \cdot V_{REF}}$$

$A = 2064$  for TC8704;  $8208$  for TC8702/TC8705

where digital counts is the value of the binary output word presented at digits out pins in response to  $V_{IN}$ .

The digital output code format is as follows:

Analog Input	Digital Outputs	
	MSB	LSB
$V_{IN} \leq \text{Full Scale}$	1 . . . 111 . . . 1	
= Full Scale -1 LSB	1 . . . 111 . . . 1	
= 1 LSB	0 . . . 000 . . . 1	
$\leq 0$	0 . . . 000 . . . 0	

Two's complement coding can be generated by inverting the Most Significant Bit (MSB) signal.

### External Component Selection

Obtaining a high-accuracy conversion system depends on the voltage regulation of  $V_{REF}$  and thermal stability of  $R_{IN}$  and  $R_{REF}$ . The exact dependence is given by the transfer function. System accuracy also depends, to a lesser degree, on the voltage regulation of  $V_{DD}$  and  $V_{SS}$ . Supply connections  $V_{DD}$  and  $V_{SS}$  should have bypass capacitors of 0.1  $\mu$ F value, or larger, at the device pins.

### $R_{IN}$ , $R_{REF}$

Values of these components are chosen to give a full-scale input current of approximately 10  $\mu$ A and a reference current of approximately -20  $\mu$ A:

$$R_{IN} \equiv \frac{V_{IN \text{ Full Scale}}}{10 \mu\text{A}} \quad R_{REF} \equiv \frac{V_{REF}}{-20 \mu\text{A}}$$

Examples:

$$R_{IN} \equiv \frac{10\text{V}}{10 \mu\text{A}} = 1 \text{ M}\Omega \quad R_{REF} \equiv \frac{-6.4\text{V}}{-20 \mu\text{A}} = 320 \text{ k}\Omega$$

Note that these values are approximations, and the exact relationships are defined by the transfer equation. In practice, the value of  $R_{IN}$  typically would be trimmed using the optional gain adjust circuit to obtain full-scale output at  $V_{IN}$  full scale (see adjustment procedure). Metal film resistors with 1% tolerance or better are recommended for high-accuracy applications because of their thermal stability and low-noise generation.

### $R_{BIAS}$

Specifications for the TC87XX are based on  $R_{BIAS} = 100 \text{ k}\Omega \pm 10\%$ , unless otherwise noted. However, there are instances when the designer may want to change this resistor in order to affect the conversion time and the supply current. By decreasing  $R_{BIAS}$ , the A/D will convert much faster and the supply current will be higher. For example, when  $R_{BIAS}$  is 20k $\Omega$ , the conversion time is reduced by 1/3, and the supply current will increase from 2 mA to 7 mA. Likewise, if  $R_{BIAS}$  is increased, the conversion time will be longer and the supply current will be much lower. For example, when  $R_{BIAS} = 1 \text{ M}\Omega$ , the conversion time will be six times longer, and supply current is now reduced to 0.5 mA. For details of this relationship, refer to AN-9 typical performance curves.

### $R_{DAMP}$

The exact value is not critical, but should have a nominal value of 100 $\Omega \pm 10\%$ . Locate close to pin 14.

### $C_{DAMP}$

The exact value is not critical, but should have a nominal value of 270 pF  $\pm 20\%$ . Locate close to pin 14.

### $C_{INT}$

The exact value is not critical, but should have a nominal value of 68 pF  $\pm 10\%$ . Low leakage types are recommended, although mica or ceramic devices can be used in applications where their temperature limits are not exceeded. Locate as close as possible to pins 14 and 15.



T-51-10-12

**BINARY OUTPUT  
ANALOG-TO-DIGITAL CONVERTERS**

TC8702  
TC8704  
TC8705

**TYPICAL APPLICATION/DESIGN CIRCUITS (Cont.)**

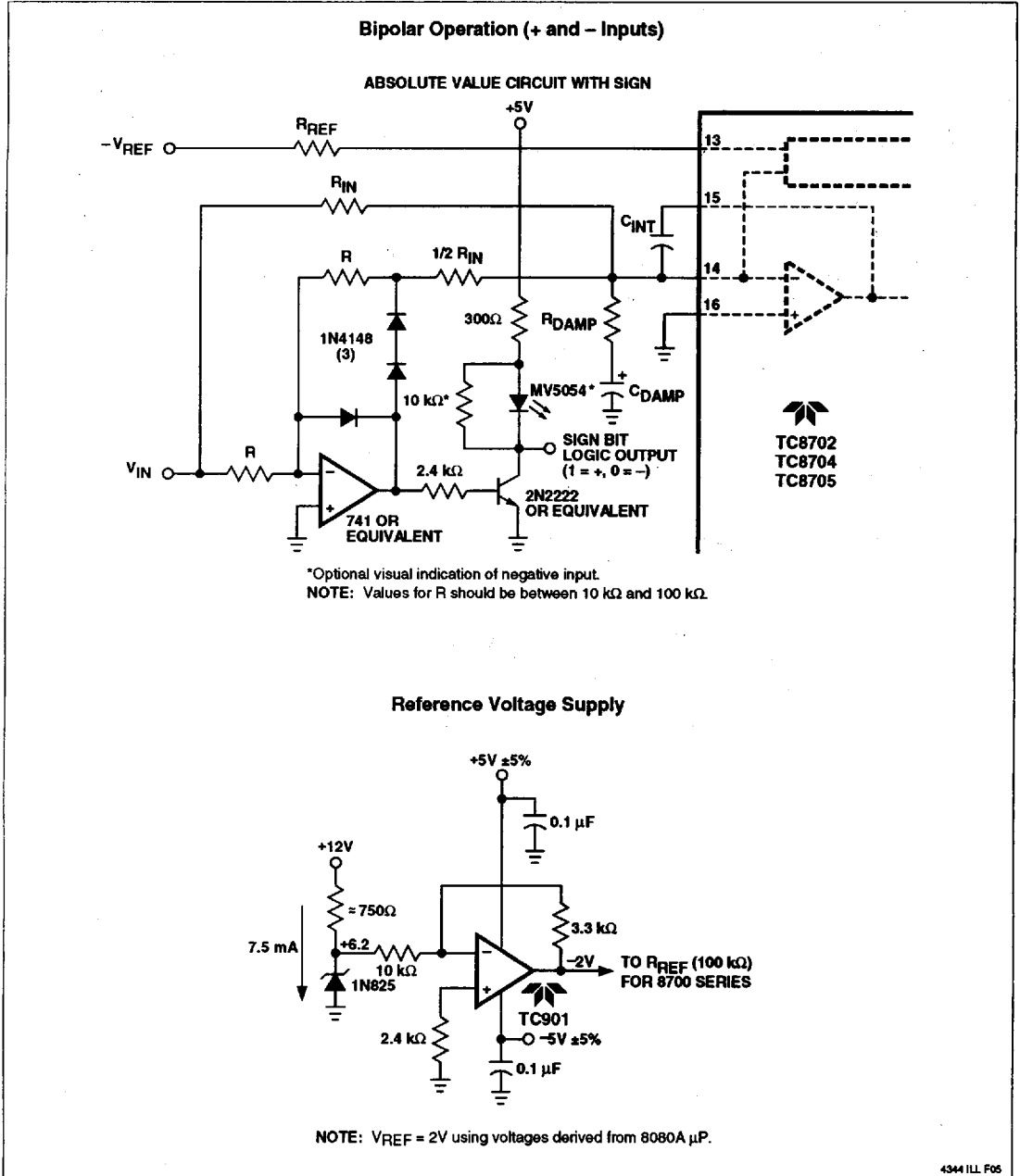

4344 ILL. P05

**BINARY OUTPUT  
ANALOG-TO-DIGITAL CONVERTERS**

T-51-10-12

TC8702  
TC8704  
TC8705

2

**TYPICAL PERFORMANCE CURVES**

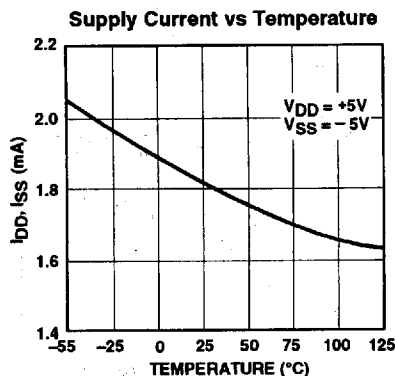
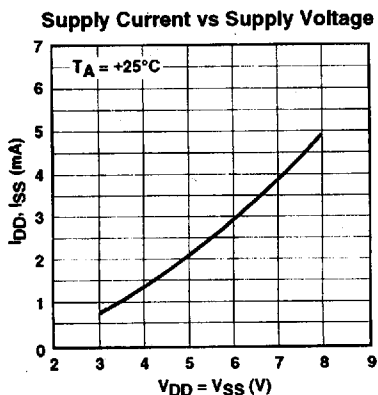
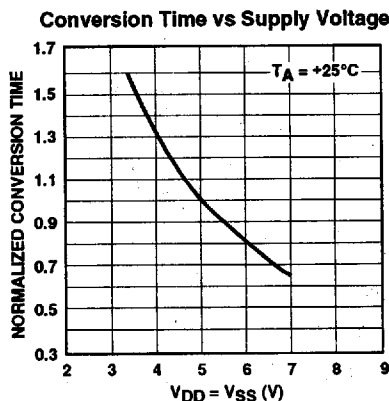
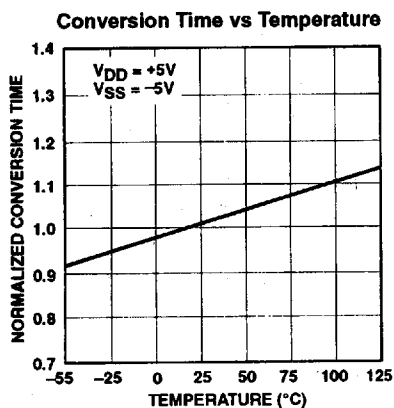
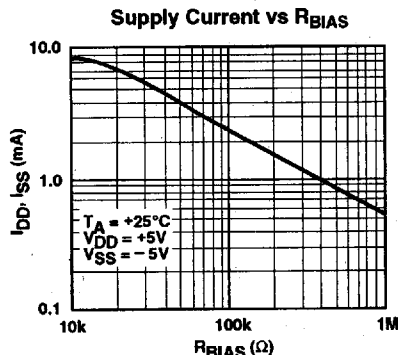
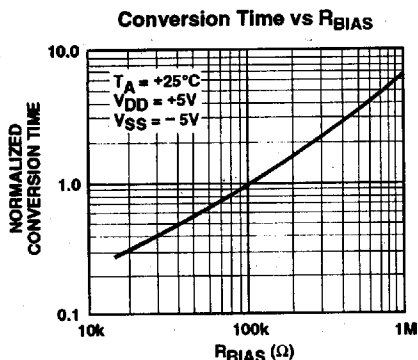

4344 ILL F06

T-51-10-12

**BINARY OUTPUT  
ANALOG-TO-DIGITAL CONVERTERS**

TC8702  
TC8704  
TC8705

**TYPICAL PERFORMANCE CURVES (Cont.)**

