

# NESSCAP 120F/2.3V

**ESLSR-0120C0-002R3**

## ■ Features

- Cylindrical cell
- Snap-in terminals

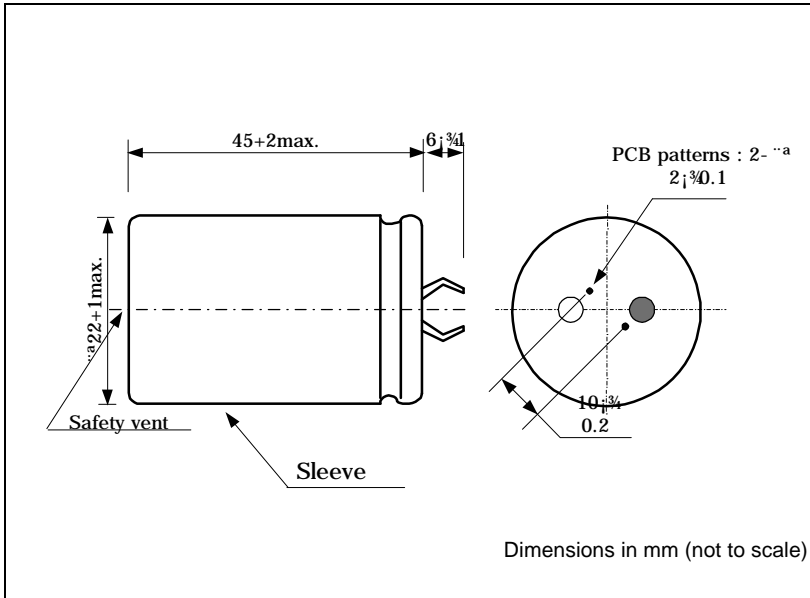

## ■ Specifications

Rated Capacitance, C (DCC <sup>(1)</sup> , 25°C)		<b>120 Farads</b>	(1) Discharging with constant current
Capacitance Tolerance		<b>-10% / +20%</b>	
Rated Voltage, V <sub>R</sub>		<b>2.3 V</b>	
Surge Voltage		<b>2.7 V</b>	
Rated Current (25°C) <sup>(2)</sup>		<b>17.2 A</b>	(2) 5 sec discharge rate to 1/2 V <sub>R</sub>
Max. Current (25°C) <sup>(3)</sup>		<b>&gt; 34.9 A</b>	(3) 1 sec discharge rate to 1/2 V <sub>R</sub>
Max. Stored Energy (at V <sub>R</sub> )		<b>317.4 J(0.0882 Wh)</b>	
Specific Energy	Gravimetric	<b>3.92 Wh/kg</b>	
	Volumetric	<b>5.16 Wh/l</b>	
Specific Power <sup>(4)</sup> (at matched load)	Gravimetric	<b>2.35 kW/kg</b>	(4) Power density at which one-half the energy of the discharge is in the form of electricity and one-half is in heat.
	Volumetric	<b>3.09 kW/l</b>	
Maximum Internal Resistance (ESR)	AC (1kHz)	<b>17 mW</b>	
	DC (11A)	<b>25 mW</b>	
Dimensions		<b>∅ 22 x l 45 mm</b>	
Volume		<b>17.1 ml</b>	
Weight		<b>22.5 g</b>	
Operating temperature range <sup>(5)</sup>		<b>-25 ~ 60 °C</b>	(5) 1/2DC 1/2 < 30% and ESR < 4 times of initially measured value at 25°C, respectively
Storage temperature range		<b>-40 ~ 85 °C</b>	
Max. Leakage Current, L <sub>C</sub> (12h, 25°C)		<b>1.7 mA</b>	
Life Time at RT <sup>(6)</sup>		<b>10 years</b>	(6) 1/2DC 1/2 < 30% and ESR < 2 times of initially measured value, respectively and LC < specified value

© NESSCAP 2003. All Rights reserved. Design, Specifications are subject to change without notice.