

FPD510-Series High Sensitivity Fast PIN Photodetector

USER MANUAL





Excitement Is Not Measureable. Light Is.

Menlo Systems, a leading developer and global supplier of instrumentation for high-precision metrology, was founded 2001 as spin-off of the Max-Planck-Institute of Quantum Optics. Known for the Nobel-Prize-winning Optical Frequency Comb technology, the Munich based company offers complete solutions based on ultrafast lasers, synchronization electronics and THz systems for applications in industry and research.

A. IMPRINT

Title: User Manual

Model: FPD510-FS-VIS, FPD510-FC-VIS,
FPD510-FS-NIR, FPD510-FC-NIR

Manufacturer: Menlo Systems GmbH, Munich, Germany

Copyright: © 2017 Menlo Systems GmbH. All rights reserved.

Reproduction by any means of any image in this user manual is prohibited without the prior consent of Menlo Systems GmbH.

All product designations used in this manual are registered trademarks of the respective companies.

Changes: Subject to technical changes without prior notice.

B. TABLE OF CONTENTS

A.	IMPRINT	3
B.	TABLE OF CONTENTS	4
1.	SAFETY INSTRUCTIONS	5
I.1	Electrical Safety Precautions.....	5
2.	System Overview	6
2.1	Contents.....	6
2.2	Connectors and Controls	7
2.3	Specifications	8
2.3.1	Response Curve.....	9
2.3.2	Frequency Characteristics	9
2.3.3	Time Characteristics and Rise Time	10
2.4	Technical Drawings.....	11
3.	Installation / Operation	13
4.	Maintenance.....	14
5.	Troubleshooting.....	15
C.	Customer Service	16
C.1	Factory Service & Repair.....	16
C.2	Additional Service Plan	16
D.	Regulatory.....	17
D.1	Waste Treatment is Your Own Responsibility.....	17
D.2	Ecological Background.....	17
E.	Contacts	18

1. SAFETY INSTRUCTIONS

I.1 ELECTRICAL SAFETY PRECAUTIONS

You should make sure that electrical equipment used for work is safe. Here is a list of actions that should be taken:

- Do not use wet hands when turning on electrical equipment.
- Check that the electrical equipment is suitable for the work and way in which it is going to be used.
- Check that the electrical equipment is in good condition.
- Check that the equipment is suitable for the electrical supply with which it is going to be used, and the electrical supply is safe.
- Make sure that the user of the equipment is trained to use it safely and can keep others safe.
- Make sure the user knows which personal protective equipment to wear, how to use it, and make sure they do so.
- Power failures should be avoided.

2. SYSTEM OVERVIEW

2.1 CONTENTS

Your photo detector case contains the following items:

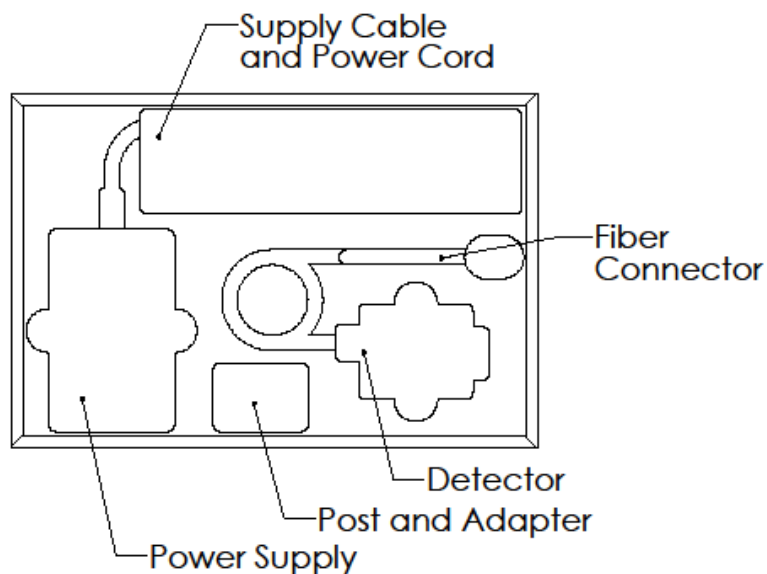

Item	Description
FPD photodetector	Photodetector FPD510
Adapter	Adapter for imperial threads (Internal 8-32 threads and external M4 x 0.7 threaded stud)
Post	40 mm post with M4 setscrew and M6 tap
Power Supply	Low noise power supply (Voltage +5V, +/- 12V, GND)
Power Cord	Power cord suitable for your country
Manual	FPD Manual
Testreport	Final Test Measurement

2.2 CONNECTORS AND CONTROLS

The detector itself has two connectors on the opposite side of the optical input:

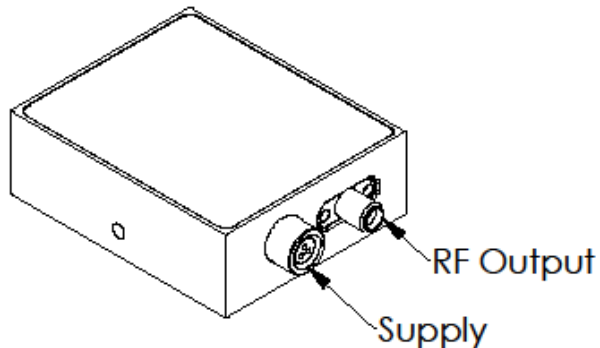

RF Output: SMA female connector

Supply: multi-contacts Fischer receptacle

Connect the *RF Output* to a 50 Ω coupled measurement tool (e.g. oscilloscope, RF spectrum analyzer,...) via SMA cable.

Connect the low voltage cable of the provided power supply to the *Supply* receptacle and plug the power cord into the 100-230 V, 50-60 Hz outlet.

Each unit's housing features an M4 x 0.7 mounting hole (an adapter for imperial mounting is enclosed) that enables the amplified photodetector to be vertically post mounted (a 40 mm post is enclosed). For more information about the location of the mounting point, please see chapter 2.4 Technical Drawings.

2.3 SPECIFICATIONS

Specifications FPD510	-FC-VIS		-FS-VIS		-FC-NIR		-FS-NIR	
Detector Type	Si		Si		InGaAs		InGaAs	
Optical Input	Fiber: FC/PC connector		Free space		Fiber: SMF28 pigtail with FC/APC		Free space	
Spectral Range [nm]	400-1000		400-1000		950-1650		950-1650	
Saturation Limit [μ W]	<100		<100		<100		<100	
Damage Threshold [mW]	3		3		3		3	
Detector Diameter [mm]	0.25		0.4		-		0.3	
Frequency Range [MHz]	DC-250		DC-250		DC-250		DC-250	
3dB Bandwidth [MHz]	DC-200		DC-200		DC-200		DC-200	
Rise Time [ns]	2		2		2		2	
Max. Gain [$V_{\text{Peak-Peak}}/W_{\text{Input}}$]	1.5×10^5		1.5×10^5		1.5×10^5		1.5×10^5	
Dark State Noise Level <small>not integrated</small> (up to 5MHz / 5-250MHz) [dBm]	-110 / -135		-110 / -135		-110 / -135		-110 / -135	
NEP (calculated) [pW/ $\sqrt{\text{Hz}}$]	6.4		6		3.0		3.2	
Output Impedance [Ω]	50		50		50		50	
Output Coupling	DC		DC		DC		DC	
Output Signal [V]	0-1		0-1		0-1		0-1	
Output Connector	SMA		SMA		SMA		SMA	
Supply Voltage [V DC]	+12	-12	+12	-12	+12	-12	+12	-12
Max. Current Consumption [mA]	50	20	50	20	50	20	50	20
Operating Temperature [$^{\circ}$ C]	10-40		10-40		10-40		10-40	
Storage Temperature [$^{\circ}$ C]	-20 - +85		-20 - +85		-20 - +85		-20 - +85	
Storage Humidity [% RH]	10-90		10-90		10-90		10-90	
Device Dimensions [mm ³]	60x50x20		60x50x20		60x50x20		60x50x20	

2.3.1 RESPONSE CURVE

The response curve for all models of the FPD series is shown below.

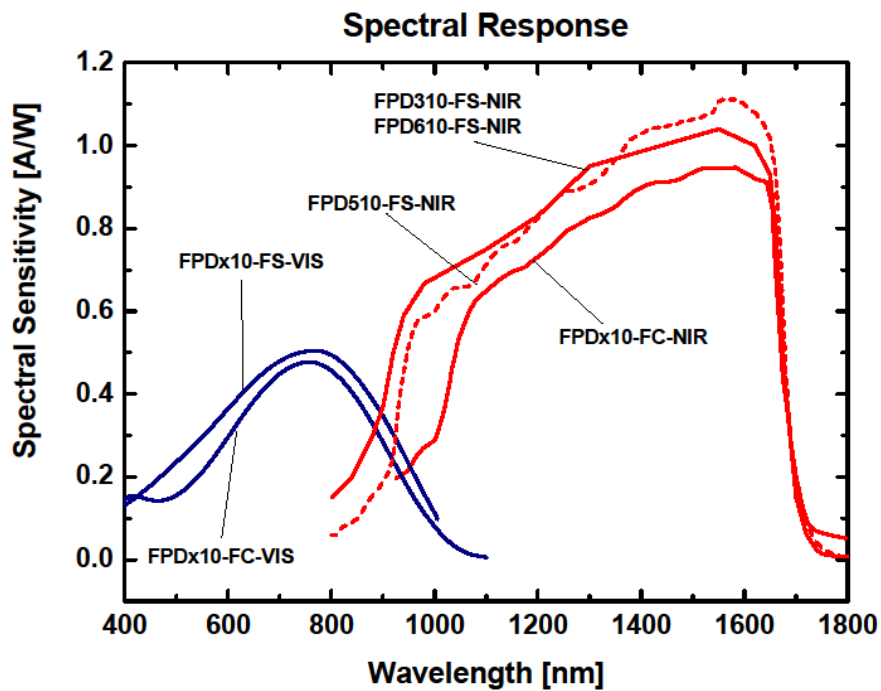

2.3.2 FREQUENCY CHARACTERISTICS

The frequency characteristics for a sub 250 fs pulse with an optical power of 5 μ W at 1560 nm and a repate of 50 MHz are shown in the graph below.

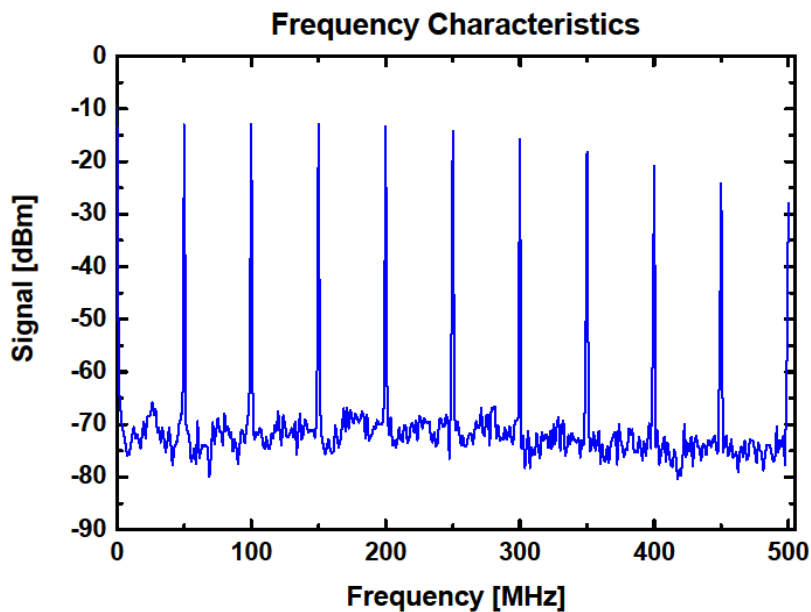

2.3.3 TIME CHARACTERISTICS AND RISE TIME

The time characteristics of the photodetector is shown in the graph below.

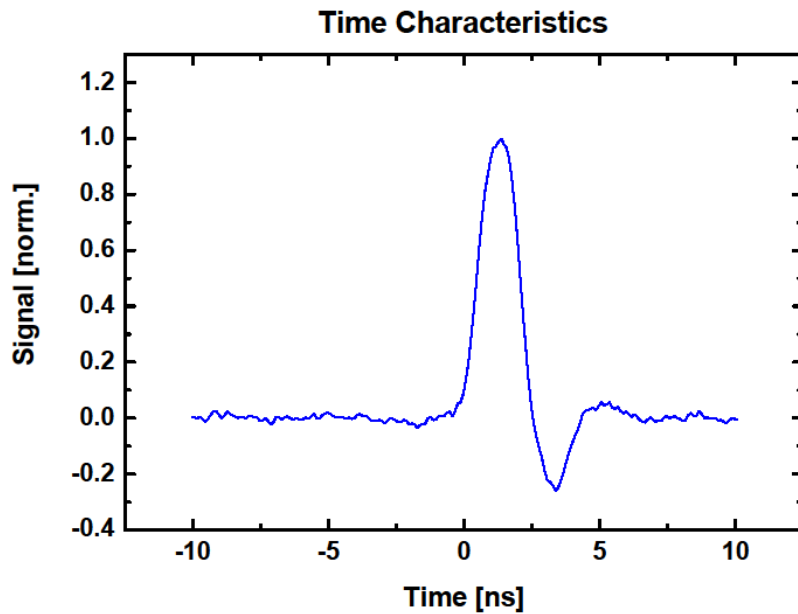

The rise time of the photodetector is defined as the time for the signal to rise from 10% up to 90% of the maximum value.

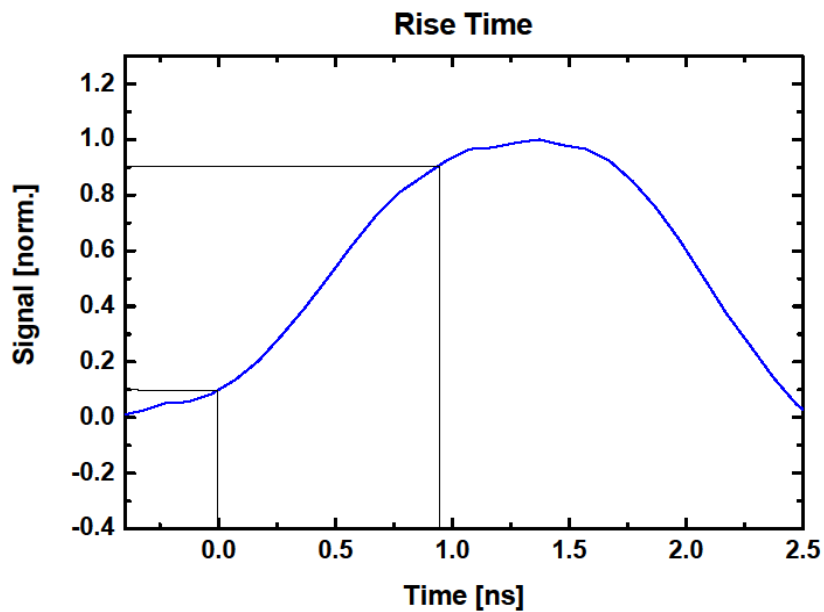

2.4 TECHNICAL DRAWINGS

Free space versions (FPD510-FS-VIS, FPD510-FS-NIR):

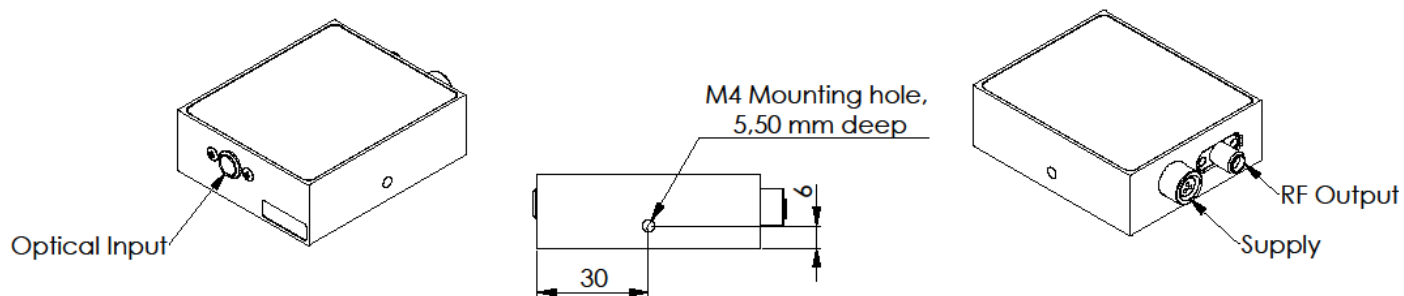

Fiber coupled version (FPD510-FC-NIR):

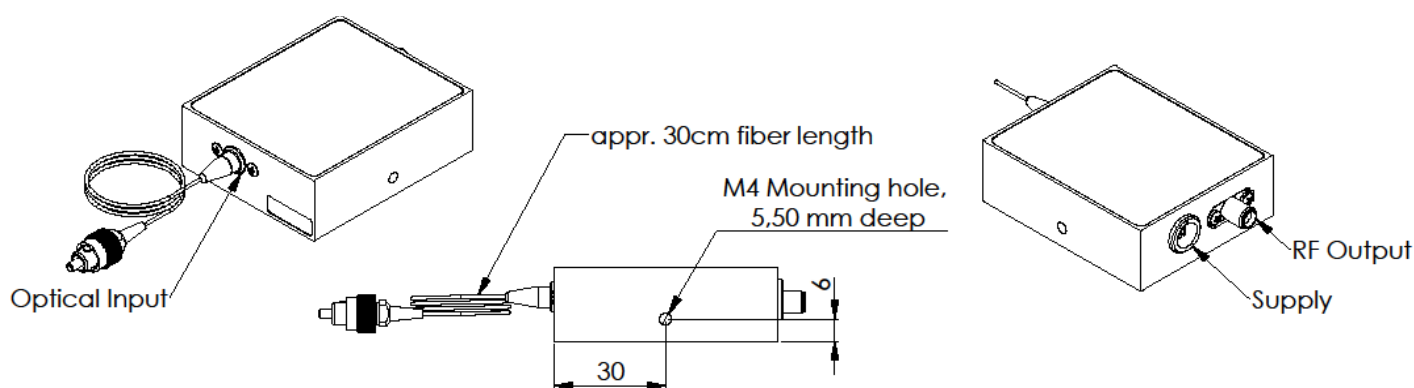

Fiber coupled version (FPD510-FC-VIS):

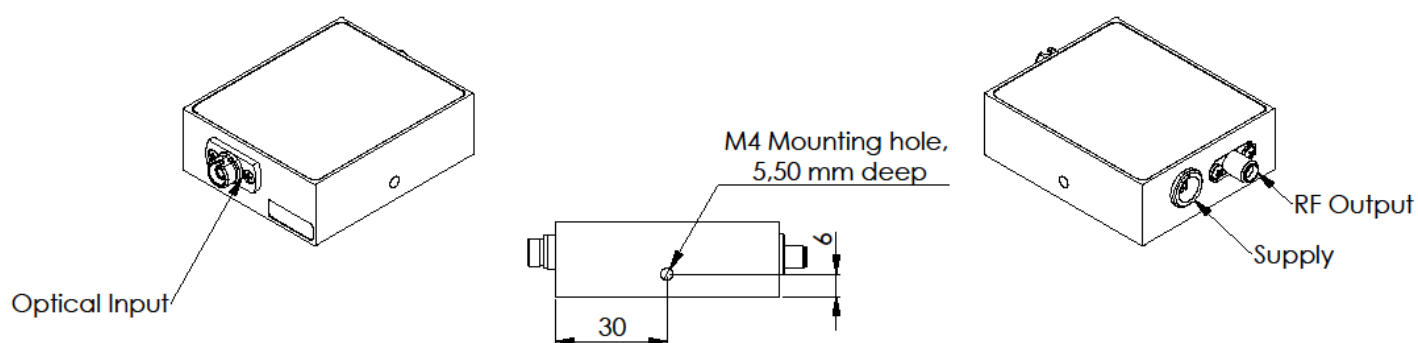

Dimensional unit is millimeter [mm].

Connection panel of the detector:

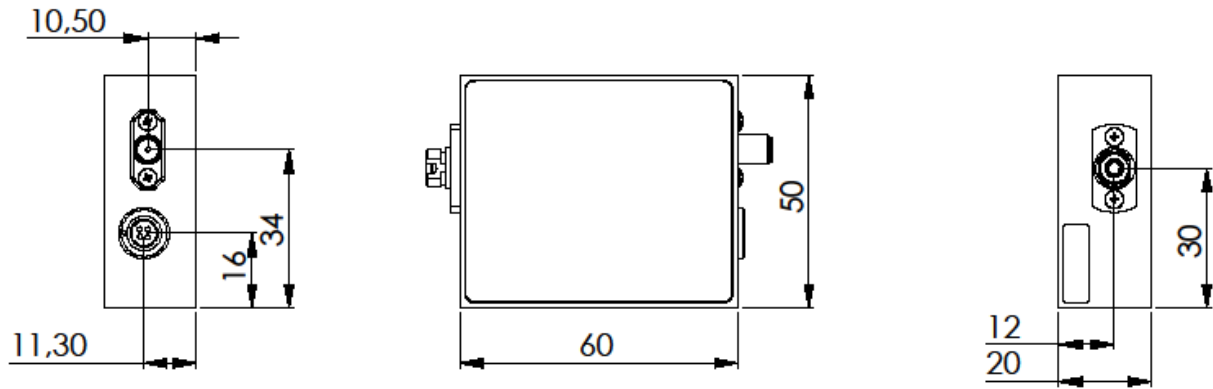

Dimensional unit is millimeter [mm].

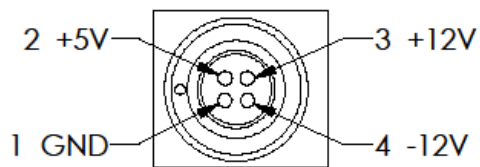

Recommended connector:
Fischerconnectors S 102 Z053-130 +

Four pole male connector on detector.

3. INSTALLATION / OPERATION

Note: To prevent humidity condensation when the detector was stored or shipped at low temperatures, let the system packed for warm-up to room temperature.

The detector should always be mounted and secured for best operation.

- Unpack the detector unit. The mounting thread is metric (M4 x 0.7). For your convenience an imperial adapter is included, if necessary. Mount it firmly.
- Connect the *RF Output* (SMA jack) to a suitable monitoring device, e.g. oscilloscope or RF-spectrum-analyzer, with 50Ω impedance. Mount the device firmly in your setup. Please note that when the device is not mounted properly, involuntary displacements during operation might occur, leading to uncontrolled reflections from the device.
- Connect the low voltage plug of the provided power supply to the *Supply* receptacle at the photo detector.
- Plug the power supply into 100 to 240 VAC, 50 to 60 Hz outlet.
- Switch on the monitoring device, and apply a light source to the detector. We recommend centering the incident light on the active area of the photodetector and not overfilling the detector area. Failing to do so may result in undesirable capacitance and resistance effects, arising from inhomogeneities at the edges of the active area of the detector, that distort the frequency response.

4. MAINTENANCE

There are no serviceable parts in the photodetector. The housing may be cleaned by wiping with a soft damp cloth. Do not use any alcohol or organic solvent to clean the mechanical parts.

If necessary, for freespace version FPD photodetectors, the window of the photo diode should only be cleaned using isopropyl alcohol and optical grade wipes. For the NIR fiber coupled detectors, the FC/APC fiber connector may only be cleaned using appropriate fiber cleaning tools.

If you suspect a problem with your photo detector, please contact Menlo Systems's technical support (service@menlosystems.com). They will be happy to assist you. For service requests, please make sure to provide the serial number of your device. For storage and shipping, please use the case your detector was shipped with.

5. TROUBLESHOOTING

This section lists error conditions the user might troubleshoot, depending on the error's root cause. If the information in this section cannot help, please contact Menlo Systems' support. The contact information is at the end of this section.

Problem	Suggested Solution
<p>There is no signal response.</p>	<ul style="list-style-type: none"> ▪ Verify that the power cord is connected and all connections are secure. ▪ Verify the proper terminating resistor is installed if using a voltage measurement device. ▪ Verify that the optical signal wavelength is within the specified spectral response curve of the detector (see 2.3.1). ▪ Verify that the optical signal is aligned with the active area of the detector. Sweep the area in the vicinity of the center. ▪ Adjust the oscilloscope to see if the signal is off the visible portion of the oscilloscope.
<p>Output Voltage will not increase.</p>	<ul style="list-style-type: none"> ▪ The photodetector might be saturated. Reduce the incident power on the detector and check again.

C. CUSTOMER SERVICE

Your system is designed to be maintenance free.

Opening the chassis of the system voids the warranty and exposes the user to hazardous voltage.

C.1 FACTORY SERVICE & REPAIR

For factory service or repair please call the Menlo Systems's customer service. Together with the product specialist they will determine if the equipment requires service, repair, calibration or replacement.

In case your system has to be returned to Menlo Systems for service or repair, we will provide an RMA number to you. For more information about the RMA procedure please read the online information at:

<http://www.menlosystems.com/legals/service-plans-returns-rma/>

C.2 ADDITIONAL SERVICE PLAN

Menlo Systems offers a Service Plan for all its products. The Service Plan includes on-site service for installation, on-site training and on-site repair service when this is technically feasible. We also support our customers during measurement campaigns. For more information please look at:

<http://www.menlosystems.com/legals/service-plans-returns-rma/>

Worldwide Support Contact except North America:

Menlo Systems GmbH
Am Klopferspitz 19a
82152 Martinsried
Germany

Phone: +49 89 189166 0
Fax: +49 89 189166 111
Timezone: CET (UTC+1) / CEST (UTC+2)

Support Contact North America:

Menlo Systems, Inc.
56 Sparta Avenue
Newton, NJ 07860
USA

Phone: +1 973 300 4490
Fax: +1 973 300 3600
Timezone: EST (UTC-5) / EDT (UTC-4)

Email: service@menlosystems.com

D. REGULATORY

As required by the WEEE (Waste Electrical and Electronic Equipment) Directive of the European Community and the corresponding national laws, Menlo Systems offers all end users in the EC the possibility to return "end of life" units without incurring disposal charges.

This offer is valid for Menlo Systems electrical and electronic equipment:

- Sold after August 13, 2005
- Marked correspondingly with the crossed out "wheelie bin" logo (see right)
- Sold to a company or institute within the EC
- Currently owned by a company or institute within the EC
- Still complete, not disassembled and not contaminated



As the WEEE directive applies to self-contained operational electrical and electronic products, this end-of-life take-back service does not refer to other Menlo Systems products, such as:

- OEM products, assemblies to be built into a unit by the user
- Components
- Mechanics and optics
- Left over parts of units disassembled by the user (PCB's, housings etc.).

If you wish to return a Menlo Systems unit for waste recovery, please contact Menlo Systems for further information.

D.1 WASTE TREATMENT IS YOUR OWN RESPONSIBILITY

If you do not return an "end of life" unit to Menlo Systems, you must hand it to a company specialized in waste recovery. Do not dispose of the unit in a litter bin or at a public waste disposal site.

D.2 ECOLOGICAL BACKGROUND

It is well known that WEEE pollutes the environment by releasing toxic products during decomposition. The aim of the European RoHS directive is to reduce the content of toxic substances in electronic products in the future. The intent of the WEEE directive is to enforce the recycling of WEEE. A controlled recycling of end of live products will thereby avoid negative impacts on the environment.

E. CONTACTS



Headquarters

Menlo Systems GmbH
Am Klopferspitz 19a
82152 Martinsried, Germany

service@menlosystems.com
sales@menlosystems.com
Phone: +49 89 189 166 0
Fax: +49 89 189 166 111

US Office

Menlo Systems, Inc.
56 Sparta Avenue
Newton, NJ 07860, USA

service@menlosystems.com
ussales@menlosystems.com
Phone: +1 973 300 4490
Fax: +1 973 300 3600