



LB1945H

Monolithic Digital IC
 PWM Current Control Type
 Stepping Motor Driver

Overview

The LB1945H is a PWM current control type stepping motor driver.

Feature

- PWM current control (external excitation)
- Load current digital selection (1-2, W1-2, and 2 phase excitation drives possible)
- Built-in upper/lower diode
- Simultaneous ON prevention function (feed-through current prevention)
- Built-in thermal shutdown circuit
- Built-in noise canceler

Specifications

Absolute Maximum Ratings at $T_a = 25^\circ\text{C}$

Parameter	Symbol	Conditions	Ratings	Unit
Maximum motor supply voltage	V_{BB} max		30	V
Output peak current	I_O peak	$t_w \leq 20\mu\text{s}$	1.0	A
Output continuous current	I_O max		0.8	A
Logic supply voltage	V_{CC} max		6.0	V
Logic input voltage range	V_{IN} max		-0.3 to V_{CC}	V
Emitter output voltage	V_E max		1.0	V
Allowable power dissipation	P_d max	Mounted on a specified board *	1.9	W
Operating temperature	T_{opr}		-20 to +90	$^\circ\text{C}$
Storage temperature	T_{stg}		-55 to +150	$^\circ\text{C}$

* Specified board: 114.3mm × 76.1mm × 1.6mm, glass epoxy board.

■ Any and all SANYO Semiconductor Co.,Ltd. products described or contained herein are, with regard to "standard application", intended for the use as general electronics equipment (home appliances, AV equipment, communication device, office equipment, industrial equipment etc.). The products mentioned herein shall not be intended for use for any "special application" (medical equipment whose purpose is to sustain life, aerospace instrument, nuclear control device, burning appliances, transportation machine, traffic signal system, safety equipment etc.) that shall require extremely high level of reliability and can directly threaten human lives in case of failure or malfunction of the product or may cause harm to human bodies, nor shall they grant any guarantee thereof. If you should intend to use our products for applications outside the standard applications of our customer who is considering such use and/or outside the scope of our intended standard applications, please consult with us prior to the intended use. If there is no consultation or inquiry before the intended use, our customer shall be solely responsible for the use.

■ Specifications of any and all SANYO Semiconductor Co.,Ltd. products described or contained herein stipulate the performance, characteristics, and functions of the described products in the independent state, and are not guarantees of the performance, characteristics, and functions of the described products as mounted in the customer's products or equipment. To verify symptoms and states that cannot be evaluated in an independent device, the customer should always evaluate and test devices mounted in the customer's products or equipment.

LB1945H

Allowable Operating Ranges at $T_a = 25^\circ\text{C}$

Parameter	Symbol	Conditions	Ratings	Unit
Motor supply voltage	V_{BB}		10 to 28	V
Logic supply voltage	V_{CC}		4.75 to 5.25	V
Reference voltage	V_{REF}		1.5 to 5.0	V

Electrical Characteristics at $T_a = 25^\circ\text{C}$, $V_{BB} = 24\text{V}$, $V_{CC} = 5\text{V}$, $V_{REF} = 5.0\text{V}$

Parameter	Symbol	Conditions	Ratings			Unit
			min	typ	max	
Output Block						
Output stage supply current	I_{BB} ON	$I_1 = 0.8\text{V}$, $I_2 = 0.8\text{V}$, ENABLE = 0.8V	0.5	1.0	2.0	mA
	I_{BB} OFF	ENABLE = 3.2V			0.2	mA
Output saturation voltage	V_{Osat1}	$I_O = +0.5\text{A}$, sink		0.3	0.5	V
	V_{Osat2}	$I_O = +0.8\text{A}$, sink		0.5	0.7	V
	V_{Osat3}	$I_O = -0.5\text{A}$, source		1.6	1.8	V
	V_{Osat4}	$I_O = -0.8\text{A}$, source		1.8	2.0	V
Output leakage current	$I_{O1}(\text{leak})$	$V_O = V_{BB}$, sink			50	μA
	$I_{O2}(\text{leak})$	$V_O = 0\text{V}$, source	-50			μA
Output sustain voltage	V_{SUS}	$L = 3.9\text{mH}$, $I_O = 1.0\text{A}$, Design guarantee value *	30			V
Logic Block						
Logic supply current	I_{CC} ON	$I_1 = 0.8\text{V}$, $I_2 = 0.8\text{V}$, ENABLE = 0.8V	50	70	92	mA
	I_{CC} OFF	ENABLE = 3.2V	7	10	13	mA
Input voltage	V_{IH}		3.2			V
	V_{IL}				0.8	V
Input current	I_{IH}	$V_{IH} = 3.2\text{V}$	35	50	65	μA
	I_{IL}	$V_{IL} = 0.8\text{V}$	7	10	13	μA
Set current control threshold value	V_{ref}/V_{sen}	$I_1 = 0.8\text{V}$, $I_2 = 0.8\text{V}$	9.5	10	10.5	
		$I_1 = 3.2\text{V}$, $I_2 = 0.8\text{V}$	13.5	15	16.5	
		$I_1 = 0.8\text{V}$, $I_2 = 3.2\text{V}$	25.5	30	34.5	
Reference current	I_{ref}	$V_{ref} = 5.0\text{V}$, $I_1 = 0.8\text{V}$, $I_2 = 0.8\text{V}$	17.5	25	32.5	μA
CR pin current	I_{CR}	CR = 1.0V	-1.0			mA
Thermal shutdown temperature	T-TSD	Design guarantee value *		170		$^\circ\text{C}$
Temperature hysteresis width	T_s hys			40		$^\circ\text{C}$

* Design guarantee value, Do not measurement.

LB1945H

Package Dimensions

unit : mm (typ)
3233B

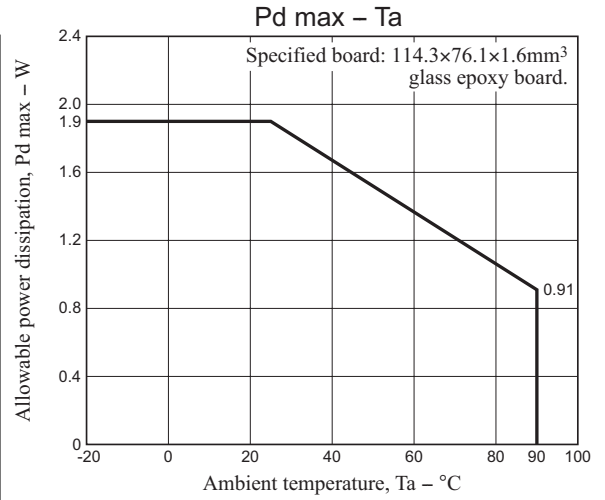
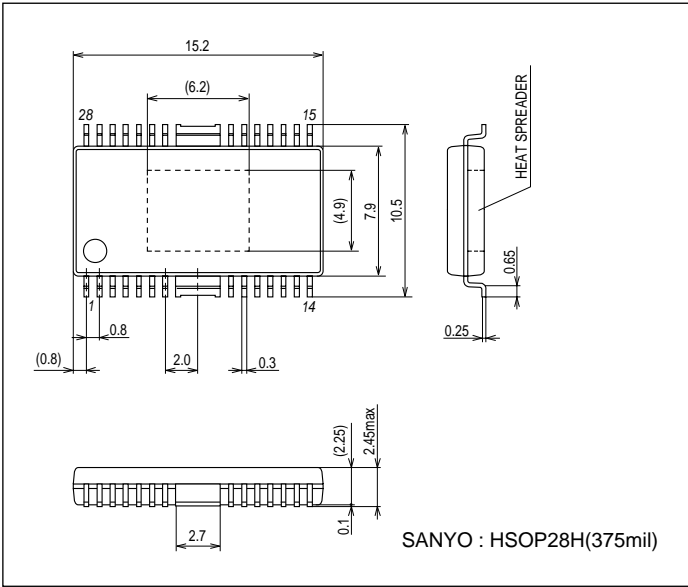

Pin Assignment

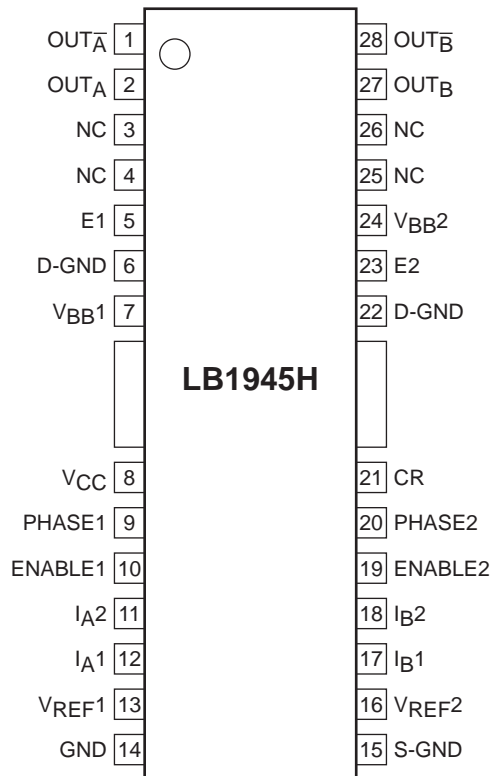

LB1945H

Block Diagram

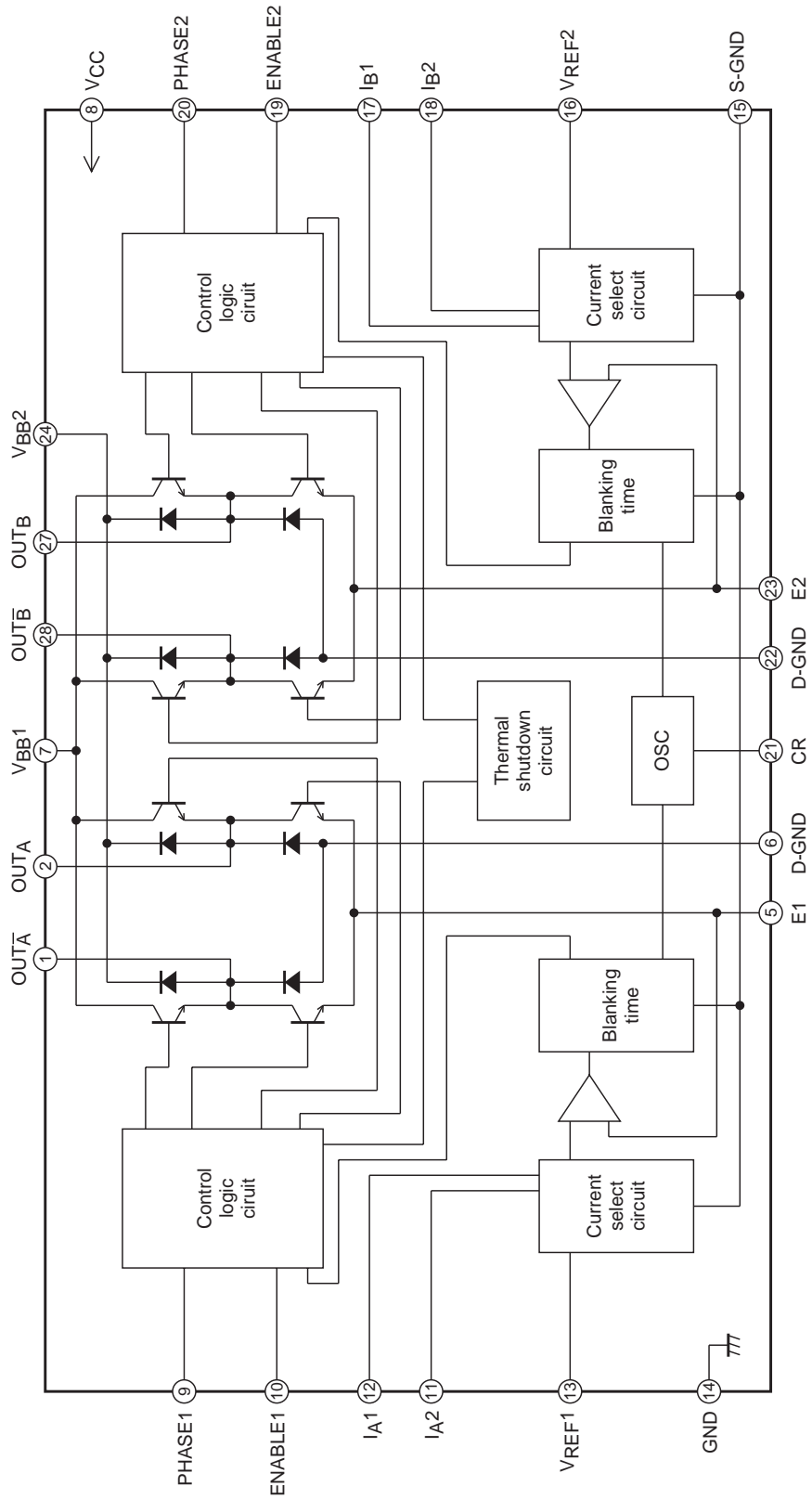

LB1945H

Truth Table

ENABLE	PHASE	OUT _A	OUT _A [̄]
L	H	H	L
L	L	L	H
H	-	OFF	OFF

I ₁	I ₂	Output current
L	L	$V_{ref} / (10 \times RE) = I_{OUT}$
H	L	$V_{ref} / (15 \times RE) = I_{OUT} \times 2/3$
L	H	$V_{ref} / (30 \times RE) = I_{OUT} \times 1/3$
H	H	0

Note: Output is OFF when ENABLE = H or when I₁ = I₂ = H.

Pin Function

Pin No.	Pin name	Function
7	V _{BB1}	Output stage power supply voltage pin.
24	V _{BB2}	Cathode pin for the upper-side diodes.
5 23	E1 E2	Insert resistor RE between these pins and ground to control set current.
2 1 27 28	OUT _A OUT _A [̄] OUT _B OUT _B [̄]	Output pins.
14	GND	Ground pin.
15	S-GND	Sense ground pin.
6 22	D-GND D-GND	Lower-side internal diode ground (anode).
21	CR	Triangular wave chopping with CR constant setting. Triangular wave OFF time is noise cancel time.
13 16	V _{REF1} V _{REF2}	Output current setting pins. (Output current is set by inputting a 1.5V to 7.5V voltage.)
9 20	PHASE1 PHASE2	Output phase select input pin. High input: OUT _A = H, OUT _A [̄] = L Low input: OUT _A = L, OUT _A [̄] = H
10 19	ENABLE1 ENABLE2	Output ON/OFF setting input pins. High input: output OFF Low input: output ON
12,11 17,18	I _{A1} , I _{A2} I _{B1} , I _{B2}	Output current setting digital input pins. Current is set to 1/3, 2/3, 1 by High and Low combinations.
8	V _{CC}	Logic block power supply voltage pin.

LB1945H

Application Circuit Example

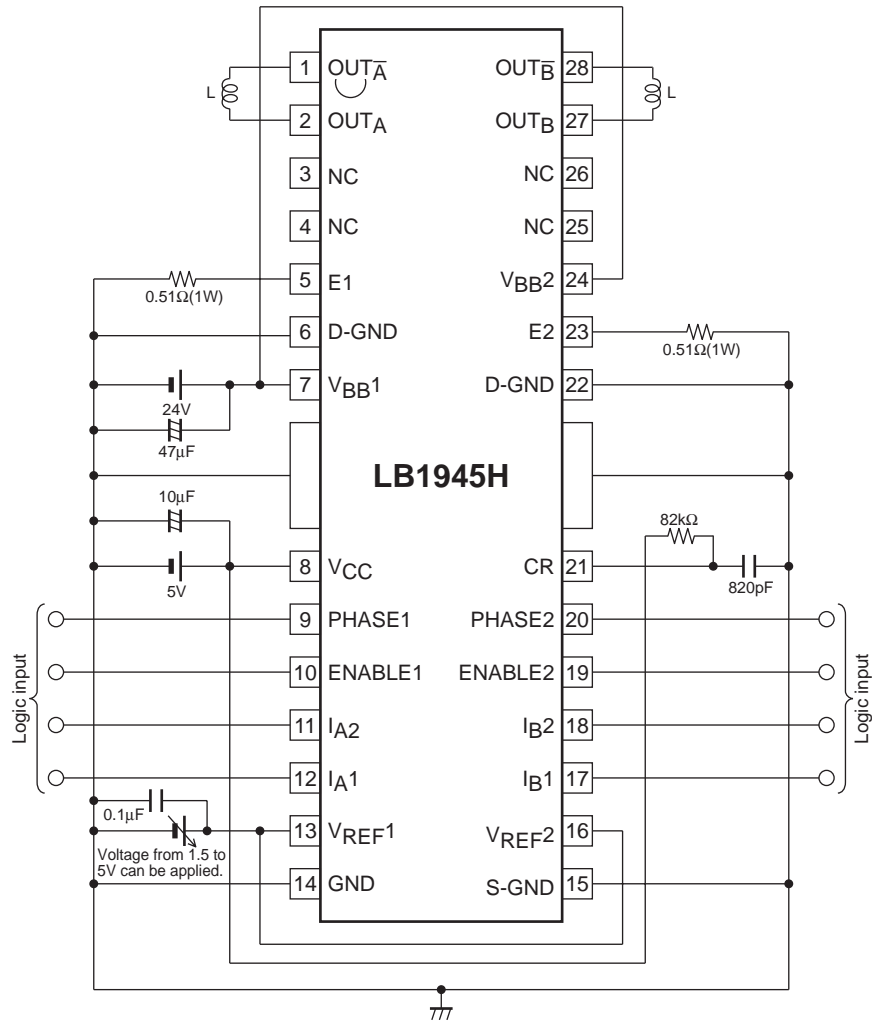

The fin on the bottom of HSOP-28H package and the fins between pins 7 and 8 and 21 and 22 should be grounded.

Usage Notes

1. VREF pin

Because the VREF pin is used as reference voltage input pin for the current setting, care must be taken to prevent noise from affecting the input.

2. GND pin

Because this IC switches large currents, the ground pattern must be designed with care. The fin on the bottom of the package and the fins between pins 7 and 8 and 21 and 22 should be grounded. Low-impedance patterns should be used in blocks where large currents flow, and these blocks should be separated from low-level signal blocks. In particular, the ground of the sense resistor RE at pin E should be located close to the IC ground. Pattern layout should be designed so that the capacitors between V_{CC} and ground and V_{BB} and ground are close to V_{CC} and V_{BB} .

- SANYO Semiconductor Co.,Ltd. assumes no responsibility for equipment failures that result from using products at values that exceed, even momentarily, rated values (such as maximum ratings, operating condition ranges, or other parameters) listed in products specifications of any and all SANYO Semiconductor Co.,Ltd. products described or contained herein.
- SANYO Semiconductor Co.,Ltd. strives to supply high-quality high-reliability products, however, any and all semiconductor products fail or malfunction with some probability. It is possible that these probabilistic failures or malfunction could give rise to accidents or events that could endanger human lives, trouble that could give rise to smoke or fire, or accidents that could cause damage to other property. When designing equipment, adopt safety measures so that these kinds of accidents or events cannot occur. Such measures include but are not limited to protective circuits and error prevention circuits for safe design, redundant design, and structural design.
- In the event that any or all SANYO Semiconductor Co.,Ltd. products described or contained herein are controlled under any of applicable local export control laws and regulations, such products may require the export license from the authorities concerned in accordance with the above law.
- No part of this publication may be reproduced or transmitted in any form or by any means, electronic or mechanical, including photocopying and recording, or any information storage or retrieval system, or otherwise, without the prior written consent of SANYO Semiconductor Co.,Ltd.
- Any and all information described or contained herein are subject to change without notice due to product/technology improvement, etc. When designing equipment, refer to the "Delivery Specification" for the SANYO Semiconductor Co.,Ltd. product that you intend to use.
- Information (including circuit diagrams and circuit parameters) herein is for example only; it is not guaranteed for volume production.
- Upon using the technical information or products described herein, neither warranty nor license shall be granted with regard to intellectual property rights or any other rights of SANYO Semiconductor Co.,Ltd. or any third party. SANYO Semiconductor Co.,Ltd. shall not be liable for any claim or suits with regard to a third party's intellectual property rights which has resulted from the use of the technical information and products mentioned above.

This catalog provides information as of March, 2009. Specifications and information herein are subject to change without notice.