

# LCD PANEL

## OPTREX TYPE NUMBERING SYSTEM

**F R S — 10111 AA P H K**

① ② ③                      ④                      ⑤                      ⑥ ⑦ ⑧

- ① LCD TYPE: F.....FEM(Field Effect Mode), G.....G/H(Guest Host Mode)  
N.....STN, V.....VHC(Very High Contrast)  
M.....MTN
- ② Display Mode: R.....Reflective T.....Transmissive S.....Transflective
- ③ Operating Method: S.....Static D.....Dynamic(Multiplex)  
X.....Compensation LCDP(Double-layer type)
- ④ Development Number.: Successive Number(4 digits or 5 digits)
- ⑤ Specification Number: Nil, A to Y or AA to YY
- ⑥ Connector: Nil.....Rubber Connector P.....Pin Connector  
F.....Flexible Connector
- ⑦ Operating temp: Nil.....Normal temp H.....Extended temp
- ⑧ Supplemented specification: D.....Dot matrix W.....Double layer  
K.....External printing J.....Internal Printing.

### Types of Display

#### Positive Type



#### Negative Type



Negative type is most suitable to display with back light.

### Light Methods

#### (1) Reflective Mode

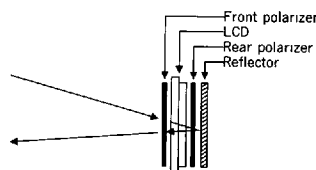

Ambient light is necessary to use this type.

#### (2) Transflective Mode

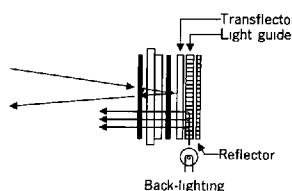

Ambient light is taken from the outside during day or in the dark and a back light is used in the dark.

#### (3) Transmissive Mode

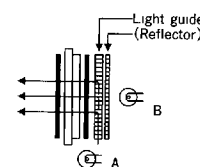

Back-lighting only. In case of B, no reflector is used

A back light is always used.

### Common Characteristics

	V <sub>0-p</sub>	Terminal	Glass Thickness	View Angle
Consumer	3.1V	Both Side	1.1mm	6:00
High Reliability	5.0V	Both Side	1.1mm	6:00

### Individual Specifications

Type No.	Glass Dimension (W×Hmm)	View Area (W×Hmm)	Digits Height (mm)	Terminal		Duty	Notes	
				Pitch	Number		Pin type	Other
F <sub>RS</sub> -1046	50.8 × 30.5	45.8 × 18.4	12.7	2.54	40	Static		
F <sub>RS</sub> -1117P(H)	50.8 × 30.5	45.8 × 18.4	12.7	2.54	40		CP-2	
F <sub>RS</sub> -1111P(H)	50.8 × 30.5	45.8 × 18.4	12.6	2.54	40		SP-1, 2, CP-1, 2	
F <sub>RS</sub> -1080P(H)	50.8 × 30.5	45.8 × 18.4	12.7	2.54	40		SP-1, CP-1, 2	
F <sub>RS</sub> -1141(H)	50.8 × 24.1	45.8 × 13.3	10.0	2.54	40		CP-2	
FRS-1143P(H)	50.8 × 24.1	45.8 × 13.3	10.0	2.54	40		CP-1, 2	
FRS-1200	50.8 × 30.5	45.8 × 18.4	12.7	2.54	40			
F <sub>RS</sub> -1105P(H)	50.8 × 30.5	45.8 × 18.4	12.7	2.54	40		SP-1, 2 CP-1, 2	
F <sub>RS</sub> -1153P(H)	69.85 × 38.1	63.5 × 24.38	17.78	2.54	40		CP-1, 2	
F <sub>RS</sub> -1154P(H)	69.85 × 30.48	63.5 × 16.51	12.7	2.54	50		CP-1, 2	
FRD-1266H	70.0 × 22.0	65.0 × 12.0	7.0	1.2	54	1/3D		4.5V drive
F <sub>RS</sub> -1320PH	81.28 × 38.1	75.28 × 24.48	17.78	2.54	40	static	CP-2	
F <sub>RS</sub> -1412P(H)	93.8 × 30.4	89.8 × 18.4	12.7	2.54	68		CP-2	
F <sub>RS</sub> -1432P(H)	137.1 × 45.7	132.1 × 33.1	25.4	2.54	70		CP-1, 2	
F <sub>RS</sub> -1574P(H)	81.28 × 38.1	75.28 × 24.48	17.78	2.54	50		CP-2	
FRD-1685PH	52.0 × 22.0	45.0 × 11.0	7.0	2.54	28	1/3D	SP-2	
FRD-0196	52.0 × 22.0	48.0 × 13.0	7.0	2.54	36	1/4D		
FRD-0346P	52.0 × 22.0	48.0 × 13.0	7.0	2.54	36		SP-2, CP-2	
FRS-4076	52.0 × 21.7	47.5 × 15.0	11.8	1.4	32	Static		
FRD-8035	48.0 × 22.5	44.0 × 14.0	6.7	2.0	20	1/4D		Glass thickness 0.7mm
FRS-1969	51.5 × 22.0	47.0 × 15.6	11.5	1.6	28	Static		Terminal; upper side only, 5V drive

■ DIMENSIONAL OUTLINE

<p><b>FSS-1046, 1117P(H) • FRS-1046, 1117P(H)</b></p> <table border="1"> <tr><th colspan="2">A</th></tr> <tr><td>1117</td><td>1117H</td></tr> <tr><td>FSS</td><td>2.59 2.72</td></tr> <tr><td>FRS</td><td>2.64 2.755</td></tr> </table>	A		1117	1117H	FSS	2.59 2.72	FRS	2.64 2.755	<p><b>FSS-1320PH • FRS-1320PH</b></p> <table border="1"> <tr><th colspan="2">A</th></tr> <tr><td>FSS</td><td>2.72</td></tr> <tr><td>FRS</td><td>2.755</td></tr> </table>	A		FSS	2.72	FRS	2.755		
A																	
1117	1117H																
FSS	2.59 2.72																
FRS	2.64 2.755																
A																	
FSS	2.72																
FRS	2.755																
<p><b>FSS-1111P(H) • FRS-1111P(H)</b></p> <table border="1"> <tr><th colspan="2">A</th></tr> <tr><td>1111</td><td>1111H</td></tr> <tr><td>FSS</td><td>2.59 2.72</td></tr> <tr><td>FRS</td><td>2.64 2.755</td></tr> </table>	A		1111	1111H	FSS	2.59 2.72	FRS	2.64 2.755	<p><b>FSS-1412P(H) • FRS-1412P(H)</b></p> <table border="1"> <tr><th colspan="2">A</th></tr> <tr><td>1412</td><td>1412H</td></tr> <tr><td>FSS</td><td>2.59 2.72</td></tr> <tr><td>FRS</td><td>2.64 2.755</td></tr> </table>	A		1412	1412H	FSS	2.59 2.72	FRS	2.64 2.755
A																	
1111	1111H																
FSS	2.59 2.72																
FRS	2.64 2.755																
A																	
1412	1412H																
FSS	2.59 2.72																
FRS	2.64 2.755																
<p><b>FSS-1080P(H) • FRS-1080(H)</b></p> <table border="1"> <tr><th colspan="2">A</th></tr> <tr><td>1080</td><td>1080H</td></tr> <tr><td>FSS</td><td>2.59 2.72</td></tr> <tr><td>FRS</td><td>2.64 2.755</td></tr> </table>	A		1080	1080H	FSS	2.59 2.72	FRS	2.64 2.755	<p><b>FSS-1432P(H) • FRS-1432P(H)</b></p> <table border="1"> <tr><th colspan="2">A</th></tr> <tr><td>1432</td><td>1432H</td></tr> <tr><td>FSS</td><td>2.59 2.72</td></tr> <tr><td>FRS</td><td>2.64 2.755</td></tr> </table>	A		1432	1432H	FSS	2.59 2.72	FRS	2.64 2.755
A																	
1080	1080H																
FSS	2.59 2.72																
FRS	2.64 2.755																
A																	
1432	1432H																
FSS	2.59 2.72																
FRS	2.64 2.755																
<p><b>FSS-1141P(H) • FRS-1141(H)</b></p> <table border="1"> <tr><th colspan="2">A</th></tr> <tr><td>1141</td><td>1141H</td></tr> <tr><td>FSS</td><td>2.59 2.72</td></tr> <tr><td>FRS</td><td>2.64 2.755</td></tr> </table>	A		1141	1141H	FSS	2.59 2.72	FRS	2.64 2.755	<p><b>FSS-1574P(H) • FRS-1574P(H)</b></p> <table border="1"> <tr><th colspan="2">A</th></tr> <tr><td>1574</td><td>1574H</td></tr> <tr><td>FRS</td><td>2.59 2.72</td></tr> <tr><td>FSS</td><td>2.64 2.755</td></tr> </table>	A		1574	1574H	FRS	2.59 2.72	FSS	2.64 2.755
A																	
1141	1141H																
FSS	2.59 2.72																
FRS	2.64 2.755																
A																	
1574	1574H																
FRS	2.59 2.72																
FSS	2.64 2.755																
<p><b>FSS-1143P(H) • FRS-1143P(H)</b></p> <table border="1"> <tr><th colspan="2">A</th></tr> <tr><td>1143</td><td>1143H</td></tr> <tr><td>FSS</td><td>2.59 2.72</td></tr> <tr><td>FRS</td><td>2.64 2.755</td></tr> </table>	A		1143	1143H	FSS	2.59 2.72	FRS	2.64 2.755	<p><b>FRD-1685PH</b></p>								
A																	
1143	1143H																
FSS	2.59 2.72																
FRS	2.64 2.755																
<p><b>FSS-1200, 1105P(H) • FRS-1200, 1105P(H)</b></p> <table border="1"> <tr><th colspan="2">A</th></tr> <tr><td>1105</td><td>1105H</td></tr> <tr><td>FSS</td><td>2.59 2.72</td></tr> <tr><td>FRS</td><td>2.64 2.755</td></tr> </table>	A		1105	1105H	FSS	2.59 2.72	FRS	2.64 2.755	<p><b>FRS-4076</b></p>								
A																	
1105	1105H																
FSS	2.59 2.72																
FRS	2.64 2.755																
<p><b>FSS-1153P(H) • FRS-1153P(H)</b></p> <table border="1"> <tr><th colspan="2">A</th></tr> <tr><td>1153</td><td>1153H</td></tr> <tr><td>FSS</td><td>2.59 2.72</td></tr> <tr><td>FRS</td><td>2.64 2.755</td></tr> </table>	A		1153	1153H	FSS	2.59 2.72	FRS	2.64 2.755	<p><b>FRD-0346P • 0196</b></p> <table border="1"> <tr><th colspan="2">A</th></tr> <tr><td>FSS</td><td>2.47</td></tr> <tr><td>FRS</td><td>2.64</td></tr> </table>	A		FSS	2.47	FRS	2.64		
A																	
1153	1153H																
FSS	2.59 2.72																
FRS	2.64 2.755																
A																	
FSS	2.47																
FRS	2.64																
<p><b>FSS-1154P(H) • FRS-1154P(H)</b></p> <table border="1"> <tr><th colspan="2">A</th></tr> <tr><td>1154</td><td>1154H</td></tr> <tr><td>FSS</td><td>2.59 2.72</td></tr> <tr><td>FRS</td><td>2.64 2.755</td></tr> </table>	A		1154	1154H	FSS	2.59 2.72	FRS	2.64 2.755	<p><b>FRD-8035</b></p>								
A																	
1154	1154H																
FSS	2.59 2.72																
FRS	2.64 2.755																
<p><b>FRD-1266H</b></p>	<p><b>FRS-1969</b></p>																

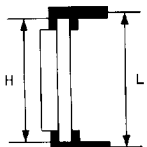

H: Dimension of Rear Glass  
L: Distance between Pins  
(Based on center of Pin)

<p><b>CP-1</b></p> <p>L = H + 2.5mm</p>	<p><b>CP-2</b></p> <p>L = H + 1.9mm</p>	<p><b>SP-1</b></p> <p>L = H + 0.3mm</p>	<p><b>SP-2</b></p> <p>L = H + 0.3mm</p>
---	---	---	---

LCD PANEL

CONNECTOR AND LCD MOUNTING METHOD To Connect LCD to the drive circuit, following connectors are available.

RUBBER CONNECTOR



**Structure**  
Alternate lamination of conductive rubber and insulating rubber.  
**Connecting Method**  
Mechanical compression.  
**Pitch(mm)**  
Min 0.4

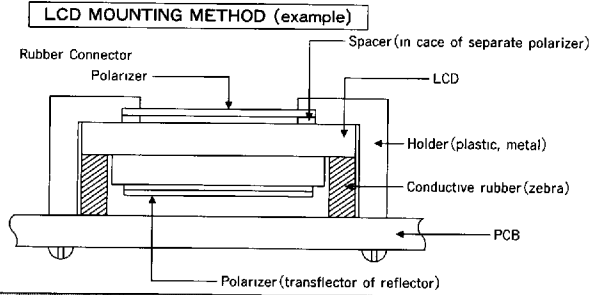

- Easy to assemble.
- Adopted for many years.
- Applicable even to narrow pads. Printed circuit boards need gold plating or graphite coating

PIN CONNECTOR

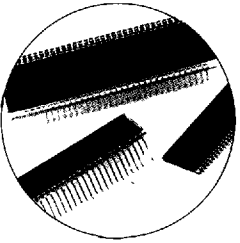

**Structure**  
Metal pins fit onto the panel terminal pad.  
**Connecting Method**  
Soldering.  
**Pitch(mm)**  
1.8, 2.0, 2.54

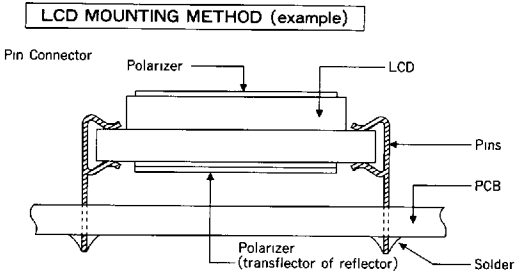

- Suitable for small production runs.

FLEXIBLE CONNECTOR

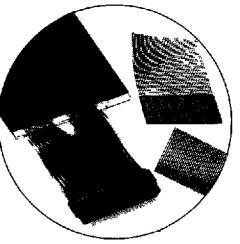

**Structure**  
Film with electroconductive thin film or printed graphite  
**Connecting Method**  
Heat and pressure fitting, Soldering or mechanical compression.  
**Pitch(mm)**  
Heat Seal: Min 0.4,  
Soldering Type: Min 1.0  
Anisotropic Type: Min 1.25

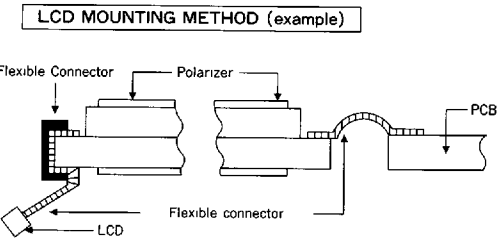

※Resin on Connecting Point

- A thin structure can be achieved.
- Possible to bend.
- Free trimming possible.

Basic Specification

■ Measurement method of optical characteristics

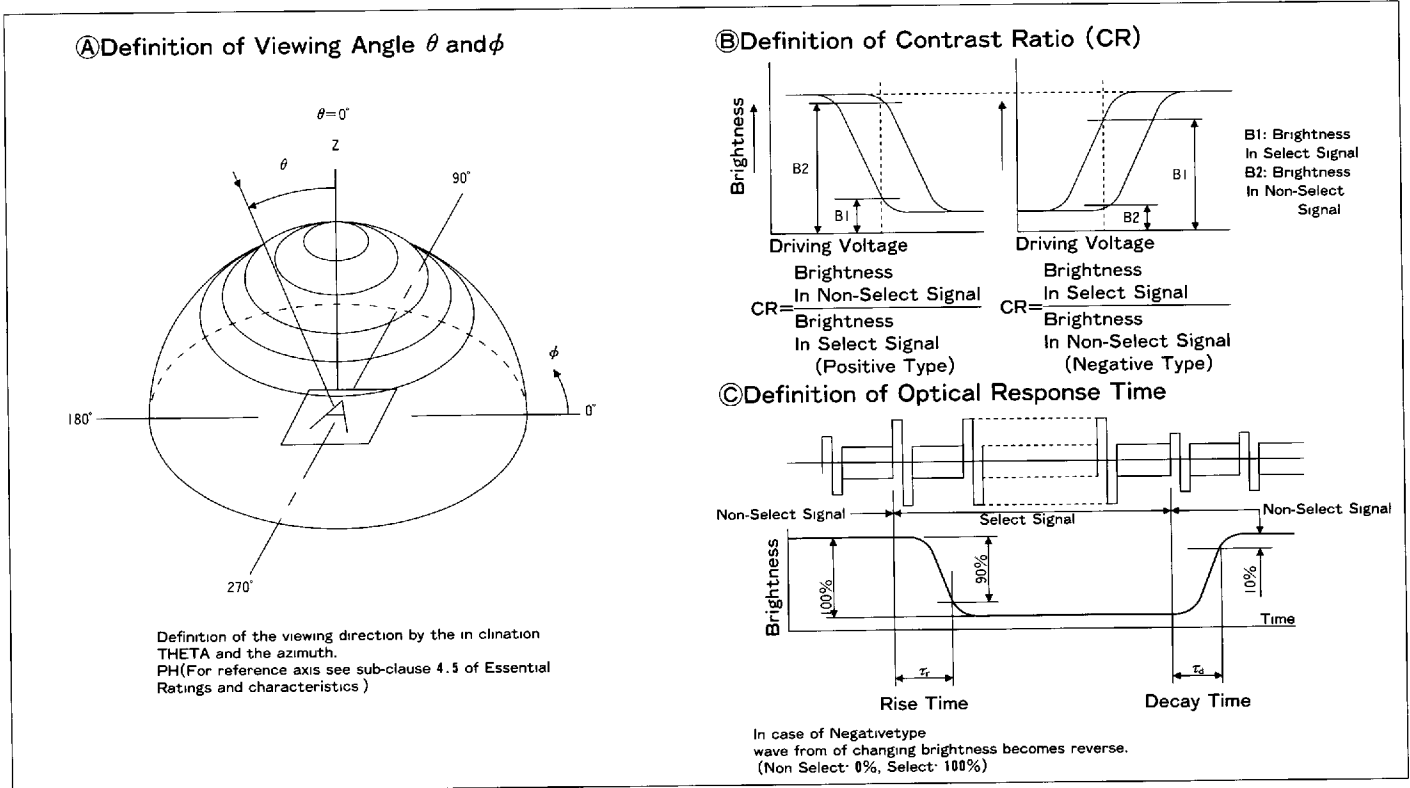

■ Reliability Conditions

LCD PANEL (A)Consumer (B)High Reliability		
Item	Conditions <small>(Evaluation is made after keeping at normal temperature (25°C) for 24 hours)</small>	Evaluation
Life Time at Normal condition	(A)Operating 50,000Hrs at normal condition (B)Operating 100,000Hrs at normal condition	No visible inferiority in appearance nor function
High Temperature Storage	(A)Storage 96Hrs at 70°C surrounding temp. (Power Off) (B)Storage 500Hrs at 85°C surrounding temp. (Power Off)	
Low Temperature Storage	(A)Storage 24Hrs at -25°C surrounding temp. (Power Off) (B)Storage 500Hrs at -40°C surrounding temp. (Power Off)	
Damp Heat	(A)Storage 96Hrs at 40°C and 90~95% RH surrounding condition (B)Storage 300Hrs at 60°C and 90% RH surrounding condition	
Thermal Shock	(A)(-25°C 30 minutes→25°C 5 minutes→70°C 30 minutes→25°C 5 minutes)×5 cycles (B)(-40°C 60 minutes→25°C 5 minutes→85°C 60 minutes→25°C 5 minutes)×20 cycles	

LCD MODULE (Consumer Type)		
Item	Conditions	Evaluation
High Temperature Operation	Operating 96~100 Hrs at 50±2°C surrounding temp.	No visible inferiority in appearance nor function
Low Temperature Operation	Operating 96~100 Hrs at 0±2°C surrounding temp. No dew to be found.	
High Temperature Storage	Storage 96~100 Hrs at 60±2°C surrounding temp. then storage 4Hrs at normal condition (Power Off)	
Low Temperature Storage	Storage 96~100 Hrs at -20±2°C surrounding temp. then storage 4Hrs at normal condition (Power Off) No dew to be found.	
Damp Proof	Storage 96~100 Hrs at 40±2°C and 90~95% RH surrounding condition, then storage 4Hrs at normal condition (Power Off) No dew to be found.	

Note: The above mentioned conditions are nominal ones, which may differ in special specifications

New Displays

**Black & White LCD Module**

**Features**

- ①Clear and legible black and white display.
- ②High contrast and wide viewing angle at high multiplex drive.
- ③High density display like CRT
- ④No temperature dependency of back ground color.

**Characteristics**

Contrast of B&W display is approx three times higher than Super TN.

**Principle**

This technology is achieved by using another layer of interference LCDP or thin film as a color compensator of optical birefringence of Super TN, while using its basic driving technique.

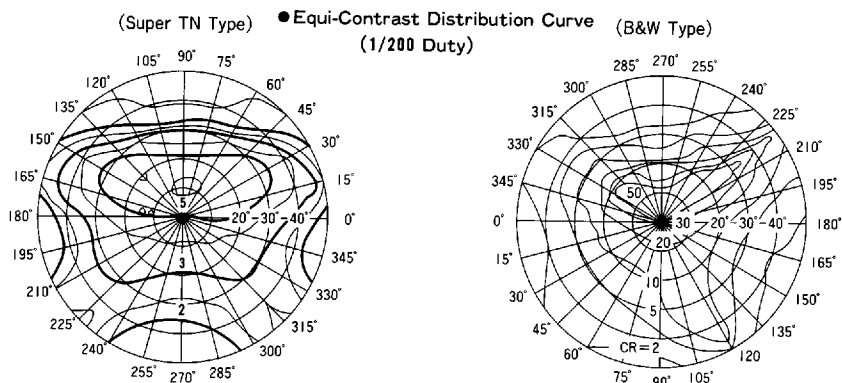

**VHC-LCD Very High Contrast LCD**

**Features**

- 1) Very high contrast (contrast ratio beyond 1000:1), little background bleed-through
- 2) Bright display, applicable to reflective mode
- 3) Little change of display color by temperature fluctuation and viewing angle difference
- 4) Quick response ( $T_R$ =less than 1300mS at  $-30^\circ\text{C}$ )

**Characteristics**

● C.R. Distribution

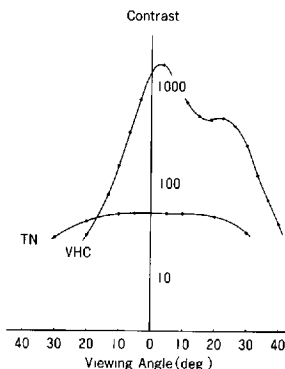

● Response Time

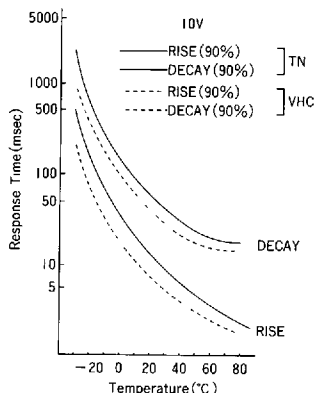

● Display Color Change

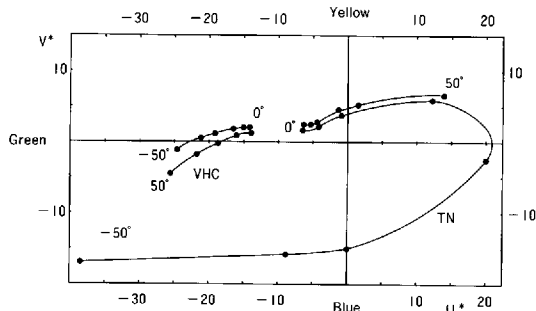

**Specifications(Reference)**

- Static drive, 5~10V<sub>0-P</sub>
- Reverse drive of positive/negative (polarizers are laminated as positive mode, OFF appearance when switch on, ON appearance when switch off)
- Internal black mask for non-segment area and color printing on rear side of LCD glass

**Internal Black Mask**

Internal black mask printing is widely used for normal TN display also, including for audio equipments, with following features.

- Perfect no bleed-through
- No parallax
- Improvement in color appearance
- Improvement in contrast

● Structure of Internal Black Mask

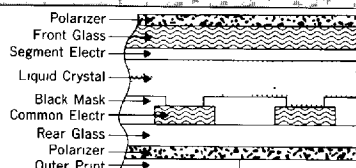

**TRANSPARENT TOUCH SWITCH**

**Features**

Transparent Touch Panel can be installed directly on LCD device and you can push touch key while observing the display. This is most suitable to input switches for various terminal application of multi-functional indicators.

**Structure**

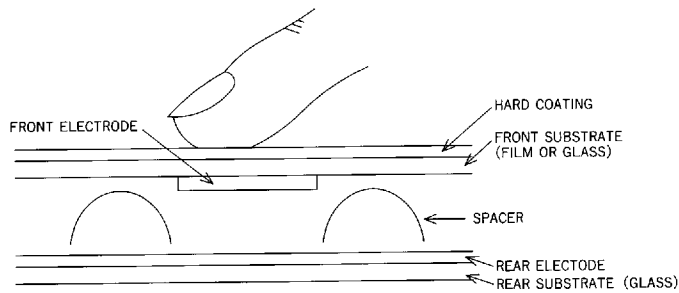
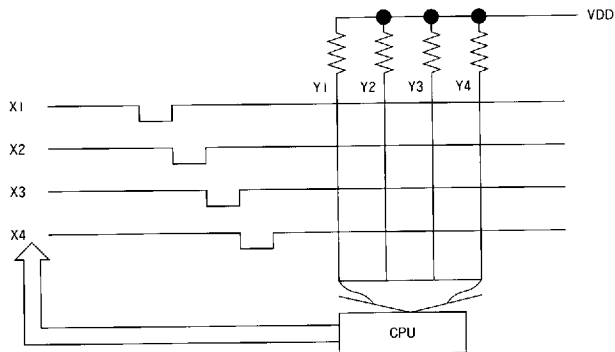
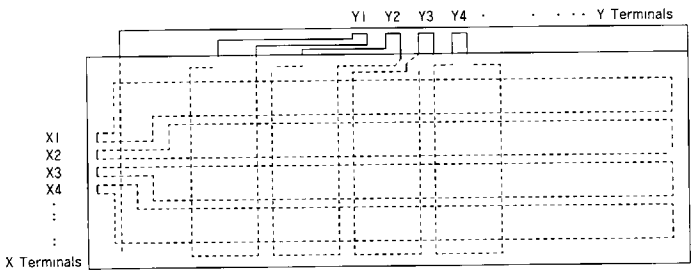

**Example of Sensor Circuit**

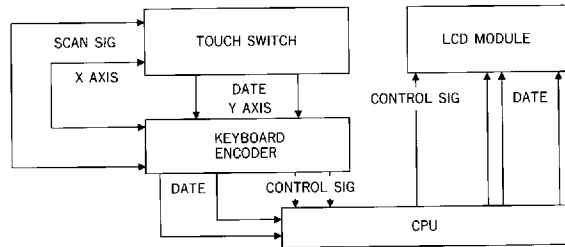

**MOUNTING/CONNECTING METHODS WITH LCD MODULE**

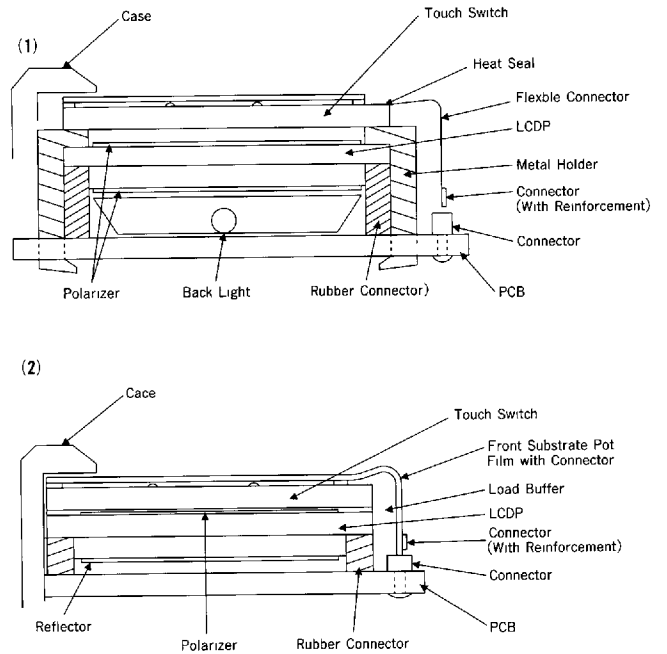

**Characteristics**

Items	Material	Film + Glass	Glass + Glass
Mechanical	Max External Dimension	300 × 300mm	200 × 165mm
	Front Substrate Thickness (Material)	125 or 188 $\mu$ (Film)	75, 125 or 185 $\mu$ (Film) + 0.2mm (Glass)
	Rear Substrate Thickness (Material)	1.1 or 2.0mm (Glass)	1.1mm (Glass)
	Switch Pattern Gap	0.4mm MIN	0.25mm MIN
	Seal Width	4.0mm MIN	2.0mm MIN
	Height of Connection Pad when using Heat Seal	4.5mm MIN	3.0mm MIN
	Operating Force	100gf MAX (R6, 30°gum)	250gf MAX (R6, 30°gum)
Electrical/Optical	Surface hardness	2H (hard coat)	
	ON resistance value	30k $\Omega$ MAX	
	Insulating resistance value	1M $\Omega$ MIN at 5V DC	
	Voltage withstanding	100V DC for 1 minute	
	On Off Balance	30m Sec MAX	
	Transparency (see Note)	70~77%	70~83%
Life Time	500,000 cycles (R6, 30°gum, 1 cycle)		

Note : Different in anti-glare type