



V53C404
HIGH PERFORMANCE, LOW POWER
1M X 4 BIT FAST PAGE MODE
CMOS DYNAMIC RAM

PRELIMINARY

HIGH PERFORMANCE V53C404	70/70L	80/80L	10/10L
Max. RAS Access Time, (t_{RAC})	70 ns	80 ns	100 ns
Max. Column Address Access Time, (t_{CAA})	35 ns	40 ns	50 ns
Min. Fast Page Mode Cycle Time, (t_{PC})	50 ns	55 ns	65 ns
Min. Read/Write Cycle Time, (t_{RC})	130 ns	150 ns	180 ns

LOW POWER V53C404L	70L	80L	10L
Max. CMOS Standby Current, (I_{DD6})	0.4 mA	0.4 mA	0.4 mA

Features-

- 1M x 4-bit organization
- RAS access time: 70,80,100 ns
- Low power dissipation
 - V53C404-10
 - Operating Current – 70 mA max.
 - TTL Standby Current – 2.0 mA max.
- Low CMOS Standby Current
 - V53C404 – 1.0 mA max.
 - V53C404L – 0.4 mA max.
- Battery Back-up Mode (V53C404L Only)
- Read-Modify-Write, RAS-Only Refresh, CAS-Before-RAS Refresh capability
- Refresh Interval
 - V53C404 – 1024 cycles/16ms
 - V53C404L – 1024 cycles/64ms
- On-chip substrate bias generator
- Fast Page Mode for a sustained data rate greater than 20 MHz
- Available in 26/20 pin SOJ package (300 mil)

cated with Vitelic's VICMOS V technology, the V53C404 offers a combination of features: Fast Page Mode for high data bandwidth, fast usable speed, CMOS standby current and, on request, extended refresh for very low data retention power (V53C404L).

All inputs and outputs are TTL compatible. Input and output capacitances are significantly lowered to allow increased system performance. Fast Page Mode operation allows random access of up to 1024 (x4) bits within a row with cycle times as short as 50 ns. Because of static circuitry, the CAS clock is not in the critical timing path. The flow-through column address latches allow address pipelining while relaxing many critical system timing requirements for fast usable speed. These features make the V53C404 ideally suited for graphics, digital signal processing and high performance computing systems.

Description

The Vitelic V53C404 is a high speed 1,048,576x4 bit CMOS dynamic random access memory. Fabri-

The V53C404L offers a maximum data retention power of 3.3 mW when operating in CMOS standby mode and performing RAS-only or CAS-before-RAS refresh cycles.

Device Usage Chart

Operating Temperature Range	Package Outline	Access Time (ns)			Power		Temperature Mark
	K	70	80	100	Low	Std.	
0°C to 70 °C	•	•	•	•	•	•	Blank

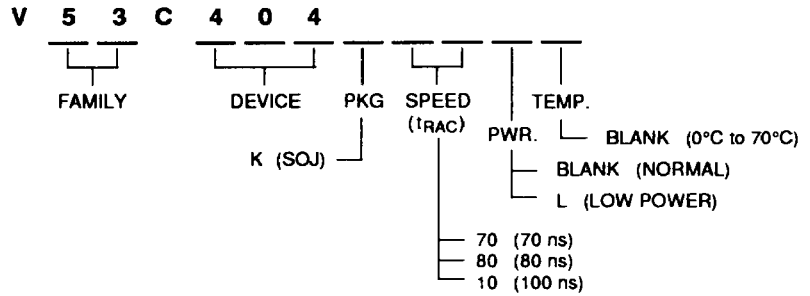

Description	Pkg.	Pin Count
SOJ	K	26/20

**26/20 Lead SOJ Package
PIN CONFIGURATION
Top View**

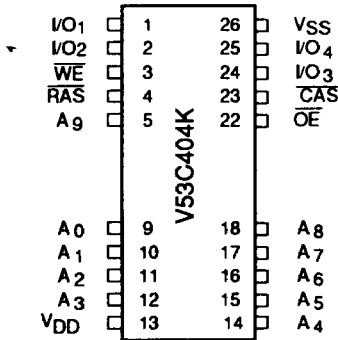

Pin Names

A_0 – A_9	Address Inputs
\overline{RAS}	Row Address Strobe
\overline{CAS}	Column Address Strobe
\overline{WE}	Write Enable
\overline{OE}	Output Enable
I/O_1 – I/O_4	Data Input, Output
V_{DD}	+5V Supply
V_{SS}	0V Supply
NC	No Connect

Absolute Maximum Ratings*

Ambient Temperature

Under Bias	–10°C to +80°C
Storage Temperature (plastic)	–55°C to +125°C
Voltage Relative to V_{SS}	–1.0 V to +7.0 V
Data Output Current	50 mA
Power Dissipation	1.0 W

*Note: Operation above Absolute Maximum Ratings can adversely affect device reliability.

Capacitance*

$T_A = 25^\circ\text{C}$, $V_{DD} = 5\text{ V} \pm 10\%$, $V_{SS} = 0\text{ V}$

Symbol	Parameter	Typ.	Max.	Unit
C_{IN1}	Address Input	—	6	pF
C_{IN2}	\overline{RAS} , \overline{CAS} , \overline{WE} , \overline{OE}	—	7	pF
C_{OUT}	Data Input/Output	—	7	pF

* Note: Capacitance is sampled and not 100% tested

Block Diagram

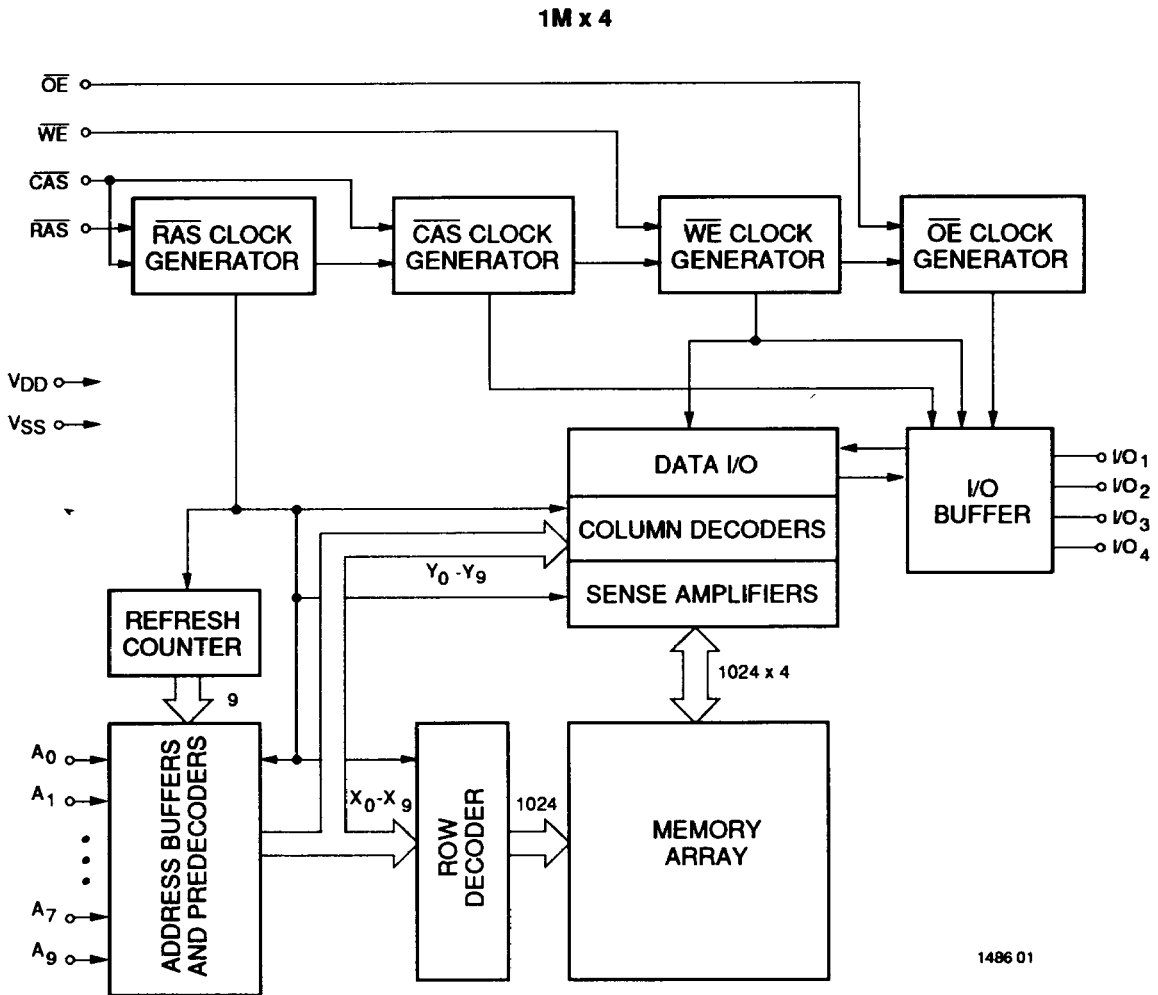

1486 01

DC and Operating Characteristics (1-2)
 $T_A = 0^\circ\text{C to } 70^\circ\text{C}$, $V_{DD} = 5\text{ V} \pm 10\%$, $V_{SS} = 0\text{ V}$, unless otherwise specified.

Symbol	Parameter	Access Time	V53C404		V53C404L		Unit	Test Conditions	Notes
			Min.	Max.	Min.	Max.			
I_{LI}	Input Leakage Current (any input pin)		-10	10	-10	10	μA	$V_{SS} \leq V_{IN} \leq V_{DD}$	
I_{LO}	Output Leakage Current (for High-Z State)		-10	10	-10	10	μA	$V_{SS} \leq V_{OUT} \leq V_{DD}$ RAS, CAS at V_{IH}	
I_{DD1}	V_{DD} Supply Current, Operating	70		90		90	mA	$t_{RC} = t_{RC}(\text{min.})$	1, 2
		80		80		80			
		100		70		70			
I_{DD2}	V_{DD} Supply Current, TTL Standby			2.0		2.0	mA	RAS, CAS at V_{IH} other inputs $\geq V_{SS}$	
I_{DD3}	V_{DD} Supply Current, RAS-Only Refresh	70		90		90	mA	$t_{RC} = t_{RC}(\text{min.})$	2
		80		80		80			
		100		70		70			
I_{DD4}	V_{DD} Supply Current, Fast Page Mode Operation	70		80		80	mA	Minimum Cycle	1, 2
		80		70		70			
		100		60		60			
I_{DD5}	V_{DD} Supply Current, Standby, Output Enabled			5		4	mA	RAS= V_{IH} , CAS= V_{IL} other inputs $\geq V_{SS}$	
I_{DD6}	V_{DD} Supply Current, CMOS Standby			1		0.4	mA	RAS $\geq V_{DD} - 0.2\text{ V}$ CAS $\geq V_{DD} - 0.2\text{ V}$ other inputs $\geq V_{SS}$	
I_{DD7}	Battery Back-up Data Retention Current (V53C404L Only)			N.A.		0.6	mA	CAS-Before-RAS Refresh cycle $t_{RC} = 62.5\ \mu\text{s}$ CMOS clock levels	18
V_{IL}	Input Low Voltage		-1.0	0.8	-1.0	0.8	V		3
V_{IH}	Input High Voltage		2.4	$V_{DD}+1$	2.4	$V_{DD}+1$	V		3
V_{OL}	Output Low Voltage			0.4		0.4	V	$I_{OL} = 4.2\text{ mA}$	
V_{OH}	Output High Voltage		2.4		2.4			$I_{OH} = -5\text{ mA}$	

AC Characteristics
 $T_A = 0^\circ\text{C to } 70^\circ\text{C}$, $V_{DD} = 5\text{ V} \pm 10\%$, $V_{SS} = 0\text{V}$ unless otherwise noted

AC Test conditions, input pulse levels 0 to 3V

#	JEDEC Symbol	Symbol	Parameter	70/L		80/L		10/L		Unit	Notes
				Min.	Max.	Min.	Max.	Min.	Max.		
1	t_{RL1RH1}	t_{RAS}	\overline{RAS} Pulse Width	70	75K	80	75K	100	75K	ns	
2	t_{RL2RL2}	t_{RC}	Read or Write Cycle Time	130		150		180		ns	
3	t_{RH2RL2}	t_{RP}	\overline{RAS} Precharge Time	50		60		70		ns	
4	t_{RL1CH1}	t_{CSH}	\overline{CAS} Hold Time	70		80		100		ns	
5	t_{CL1CH1}	t_{CAS}	\overline{CAS} Pulse Width	20		20		25		ns	
6	t_{RL1CL1}	t_{RCD}	\overline{RAS} to \overline{CAS} Delay	20	50	20	60	25	75	ns	4
7	t_{WH2CL2}	t_{RCS}	Read Command Setup Time	0		0		0		ns	
8	t_{AVRL2}	t_{ASR}	Row Address Setup Time	0		0		0		ns	
9	t_{RL1AX}	t_{RAH}	Row Address Hold Time	10		10		15		ns	
10	t_{AVCL2}	t_{ASC}	Column Address Setup Time	0		0		0		ns	
11	t_{CL1AX}	t_{CAH}	Column Address Hold Time	15		15		20		ns	
12	$t_{CL1RH1(R)}$	$t_{RSH(R)}$	\overline{RAS} Hold Time (Read Cycle)	20		20		25		ns	
13	t_{CH2RL2}	t_{CRP}	\overline{CAS} to \overline{RAS} Precharge Time	5		5		10		ns	
14	t_{CH2WX}	t_{RCH}	Read Command Hold Time Referenced to \overline{CAS}	0		0		0		ns	5
15	t_{RH2WX}	t_{RRH}	Read Command Hold Time Referenced to \overline{RAS}	0		0		0		ns	5
16	$t_{OEL1RH2}$	t_{ROH}	\overline{RAS} Hold Time Referenced to \overline{OE}	20		20		25		ns	
17	t_{GL1OV}	t_{OAC}	Access Time from \overline{OE}		20		20		25	ns	
18	t_{CL1OV}	t_{CAC}	Access Time from \overline{CAS}		20		20		25	ns	6,7
19	t_{RL1OV}	t_{RAC}	Access Time from \overline{RAS}		70		80		100	ns	6,8,9
20	t_{AVOV}	t_{CAA}	Access Time from Column Address		35		40		50	ns	6,7,10

AC Characteristics (Cont'd.)

#	JEDEC Symbol	Symbol	Parameter	70/L		80/L		10/L		Unit	Notes
				Min.	Max.	Min.	Max.	Min.	Max.		
21	t_{CL10X}	t_{LZ}	\overline{OE} or \overline{CAS} to Low-Z Output	0		0		0		ns	16
22	t_{CH20Z}	t_{HZ}	\overline{OE} or \overline{CAS} to High-Z Output	0	20	0	25	0	25	ns	16
23	t_{RL1AX}	t_{AR}	Column Address Hold Time from \overline{RAS}	55		60		75		ns	
24	t_{RL1AV}	t_{RAD}	\overline{RAS} to Column Address Delay Time	15	35	15	40	20	50	ns	11
25	$t_{CL1RH1(W)}$	$t_{RSH(W)}$	\overline{RAS} or \overline{CAS} Hold Time in Write Cycle	20		20		25		ns	
26	t_{WL1CH1}	t_{CWL}	Write Command to \overline{CAS} Lead Time	20		20		25		ns	
27	t_{WL1CL2}	t_{WCS}	Write Command Setup Time	0		0		0		ns	12,13
28	t_{CL1WH1}	t_{WCH}	Write Command Hold Time	10		15		20		ns	
29	t_{WL1WH1}	t_{WP}	Write Pulse Width	10		15		20		ns	
30	t_{RL1WH1}	t_{WCR}	Write Command Hold Time from \overline{RAS}	55		60		75		ns	
31	t_{WL1RH1}	t_{RWL}	Write Command to \overline{RAS} Lead Time	20		20		25		ns	
32	t_{DVWL2}	t_{DS}	Data in Setup Time	0		0		0		ns	14
33	t_{WL1DX}	t_{DH}	Data in Hold Time	15		15		20		ns	14
34	t_{WL1GL2}	t_{WOH}	Write to \overline{OE} Hold Time	20		20		25		ns	14
35	t_{GH2DX}	t_{OED}	\overline{OE} to Data Delay Time	20		20		25		ns	14
36	$t_{RL2RL2(RMW)}$	t_{RWC}	Read-Modify-Write Cycle Time	185		205		245		ns	
37	$t_{RL1RH1(RMW)}$	t_{RRW}	Read-Modify-Write Cycle \overline{RAS} Pulse Width	125		135		165		ns	
38	t_{CL1WL2}	t_{CWD}	\overline{CAS} to \overline{WE} Delay	50		50		60		ns	12
39	t_{RL1WL2}	t_{RWD}	\overline{RAS} to \overline{WE} Delay in Read-Modify-Write Cycle	100		110		135		ns	12
40	t_{CL1CH1}	t_{CRW}	\overline{CAS} Pulse Width (RMW)	75		75		90		ns	

AC Characteristics (Cont'd.)

#	JEDEC Symbol	Symbol	Parameter	70/L		80/L		10/L		Unit	Notes
				Min.	Max.	Min.	Max.	Min.	Max.		
41	t_{AVWL2}	t_{AWD}	Col. Address to \overline{WE} Delay	65		70		80		ns	12
42	t_{CL2CL2}	t_{PC}	Fast Page Mode Read or Write Cycle Time	50		55		65		ns	
43	t_{CH2CL2}	t_{CP}	\overline{CAS} Precharge Time	10		10		10		ns	
44	t_{AVRH1}	t_{CAR}	Column Address to \overline{RAS} Setup Time	35		40		50		ns	
45	t_{CH2QV}	t_{CAP}	Access Time from Column Precharge		40		45		55	ns	7
46	t_{RL1DX}	t_{DHR}	Data in Hold Time Referenced to \overline{RAS}	55		60		75		ns	
47	t_{CL1RL2}	t_{CSR}	\overline{CAS} Setup Time \overline{CAS} -before- \overline{RAS} Refresh	5		5		5		ns	
48	t_{RH2CL2}	t_{RPC}	\overline{RAS} to \overline{CAS} Precharge Time	5		5		5		ns	
49	t_{RL1CH1}	t_{CHR}	\overline{CAS} Hold Time \overline{CAS} -before- \overline{RAS} Refresh	15		15		15		ns	
50	t_{CL2CL2} (RMW)	t_{PCM}	Fast Page Mode Read- Modify-Write Cycle Time	105		110		130		ns	
51	t_{WH2RL2}	t_{WRP}	\overline{WE} to \overline{RAS} precharge time (\overline{CAS} -Before- \overline{RAS} Refresh cycle)	10		10		10		ns	
52	t_{RL1WL2}	t_{WRH}	\overline{WE} Hold Time from \overline{RAS} (\overline{CAS} -Before- \overline{RAS} Refresh Cycle)	10		10		10		ns	
53	t_{WL1RL2}	t_{WSR}	\overline{RAS} to \overline{WE} set-up Time (Test Mode)	10		10		10		ns	19 20
54	t_{RL1WH1}	t_{WHR}	\overline{RAS} to \overline{WE} hold Time (Test Mode)	10		10		10		ns	
55	t_T	t_T	Transition Time (Rise and Fall)	3	50	3	50	3	50	ns	15
56		t_{REF}	Refresh Interval (1024 Refresh Cycles)		16		16		16	ms	17
57		t_{REF}	Refresh Interval V53C404L Only (1024 Refresh Cycles, $t_{RC} = 62.5 \mu s$)		64		64		64	ms	17,18

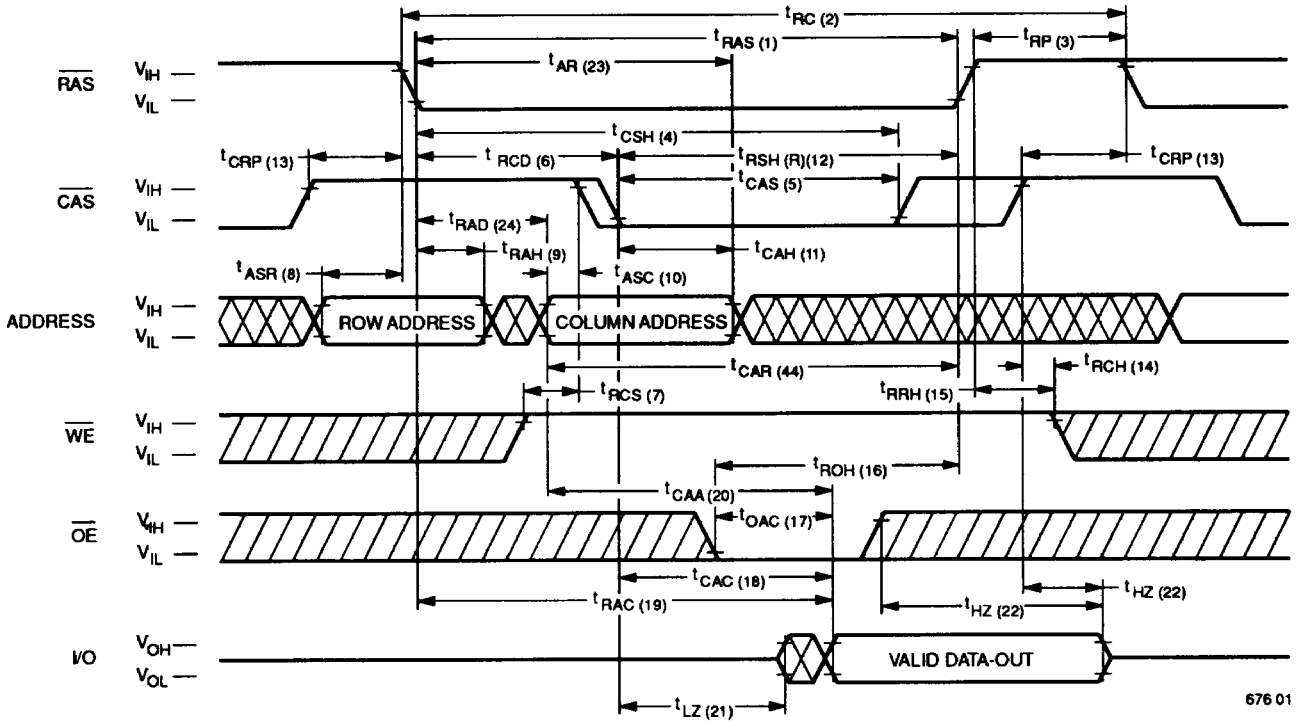
Waveforms of Read Cycle

676 01

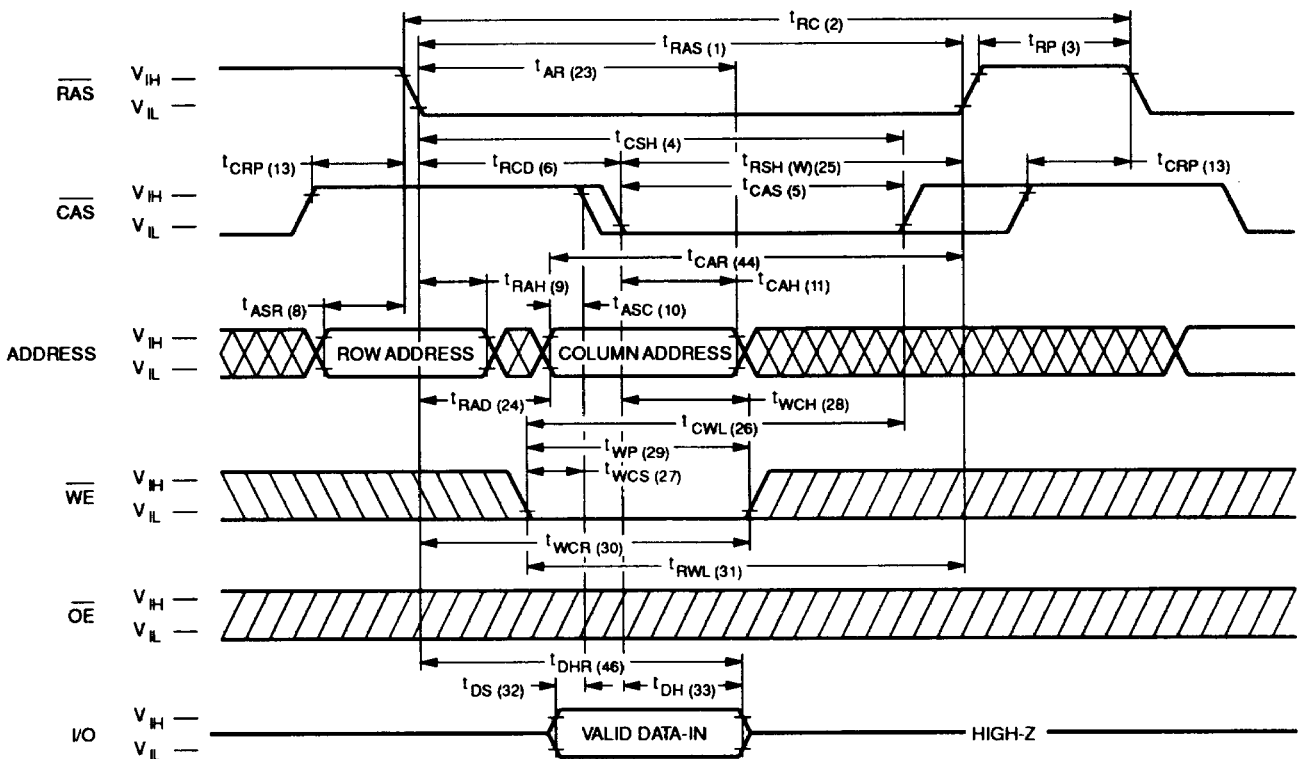
Waveforms of Early Write Cycle

676 02

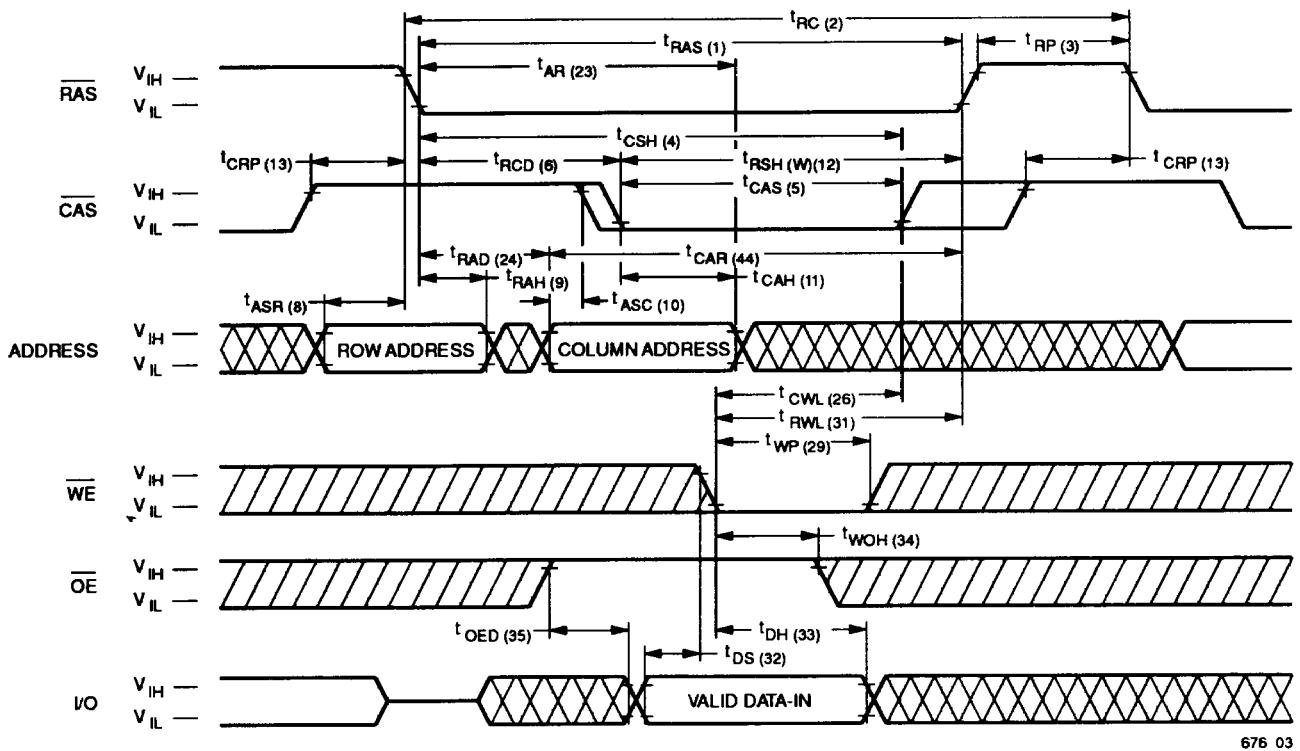
Waveforms of OE-Controlled Write Cycle

676 03

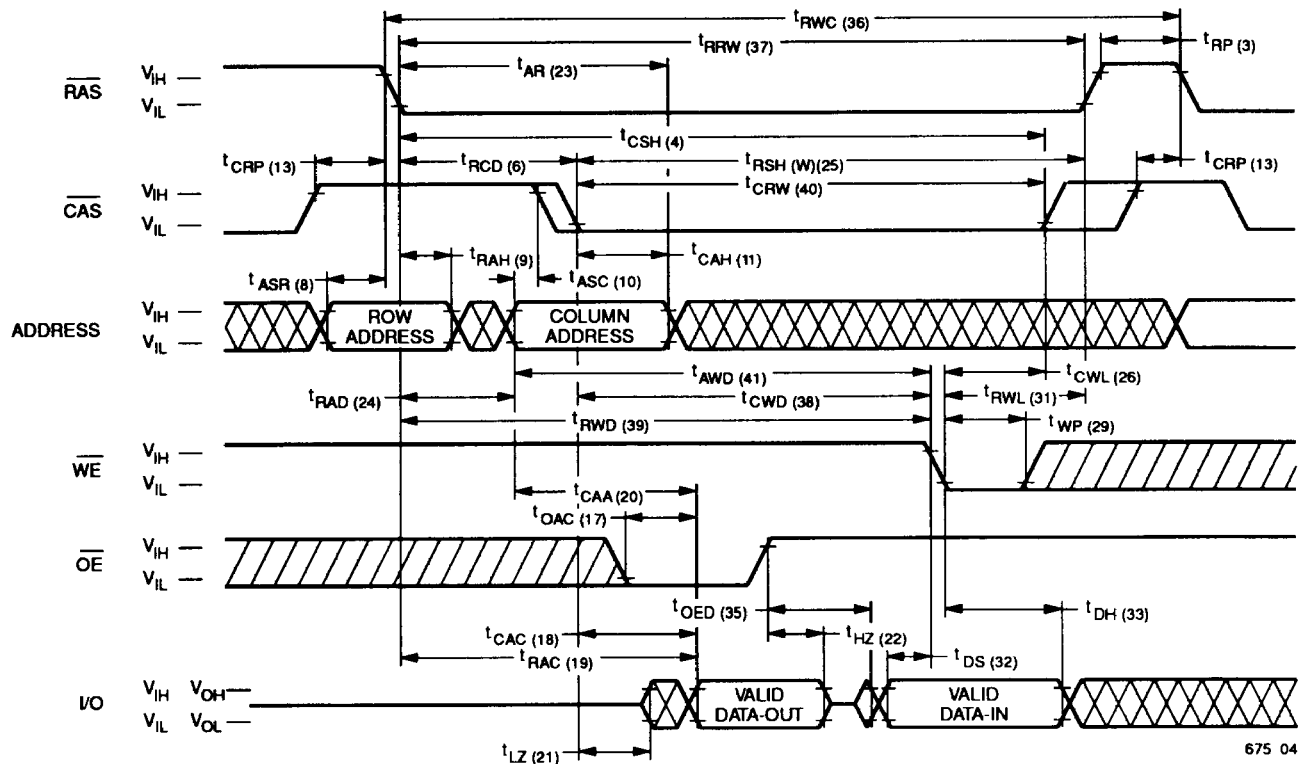
Waveforms of Read-Modify-Write Cycle

675 04

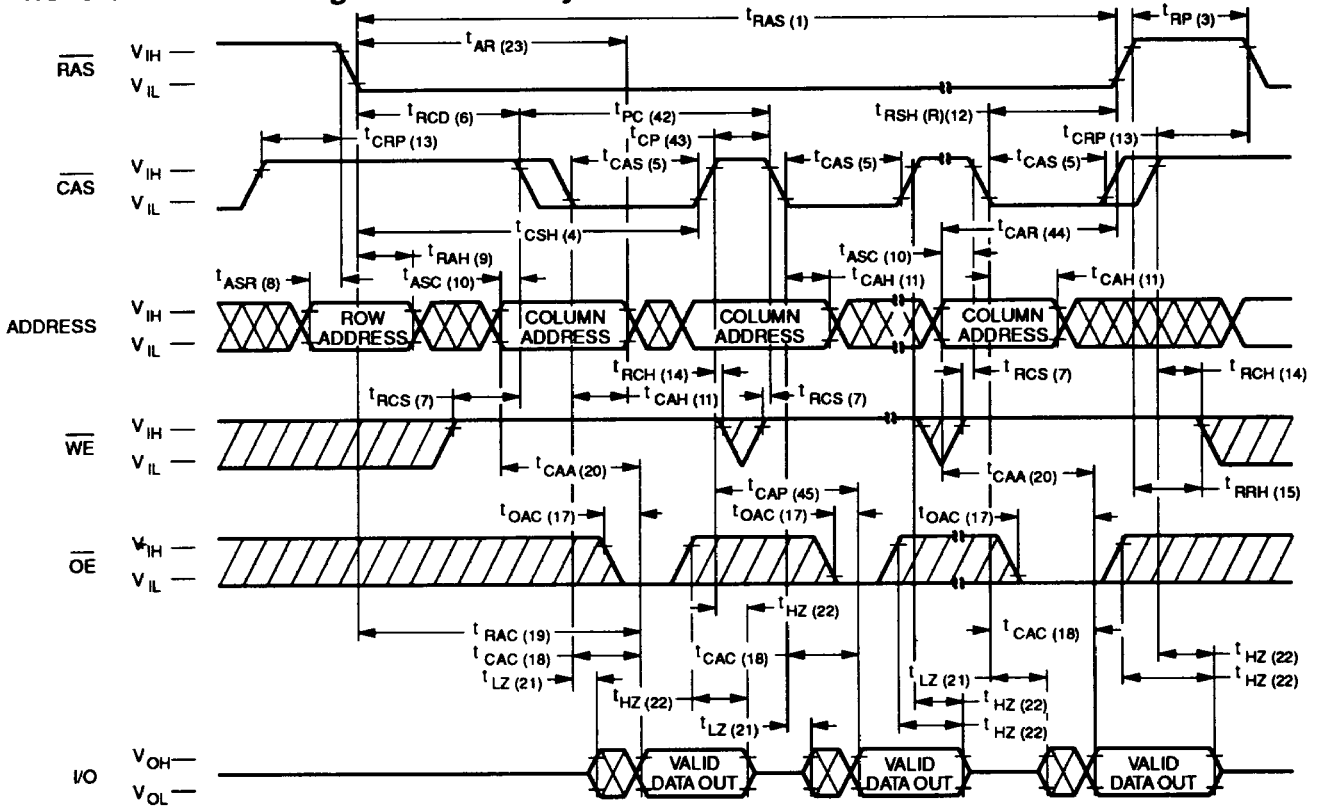
Waveforms of Fast Page Mode Read Cycle

676 05

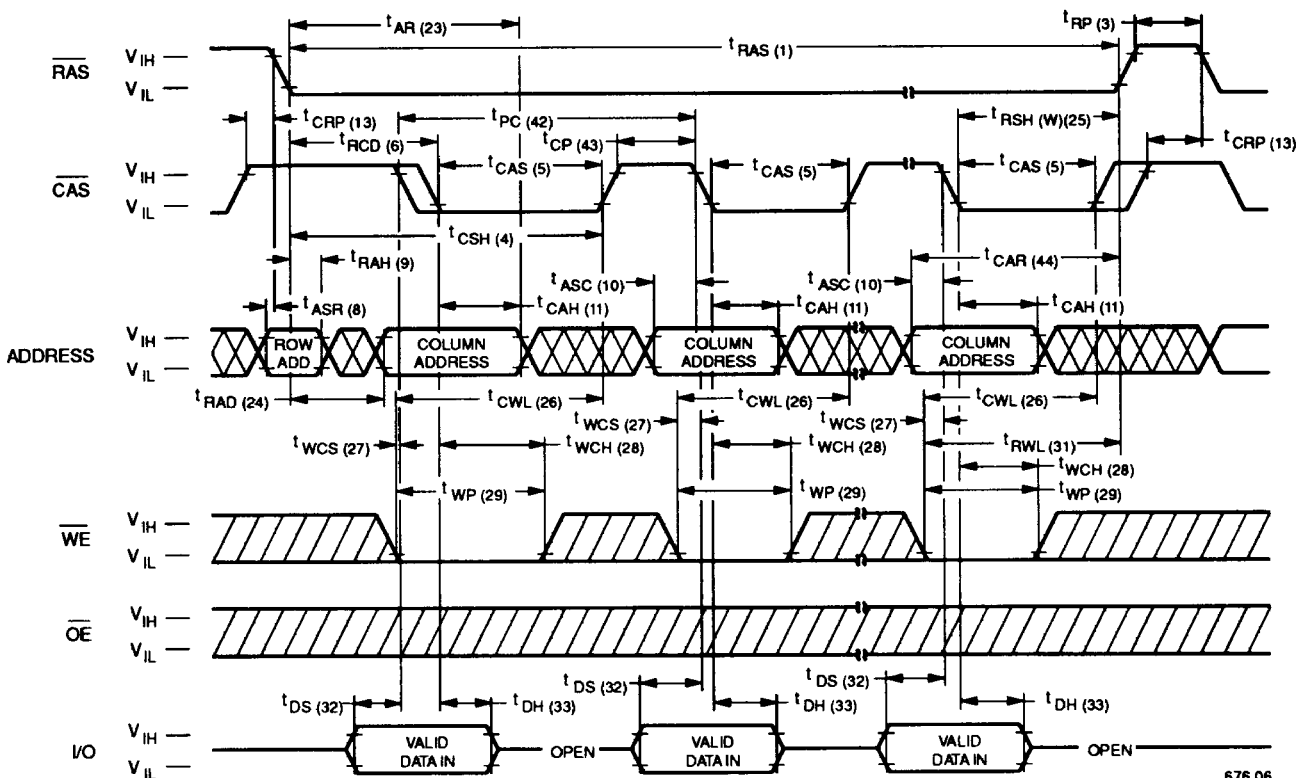
Waveforms of Fast Page Mode Write Cycle

676 06

Waveforms of $\overline{\text{CAS}}$ -before- $\overline{\text{RAS}}$ Refresh Cycle

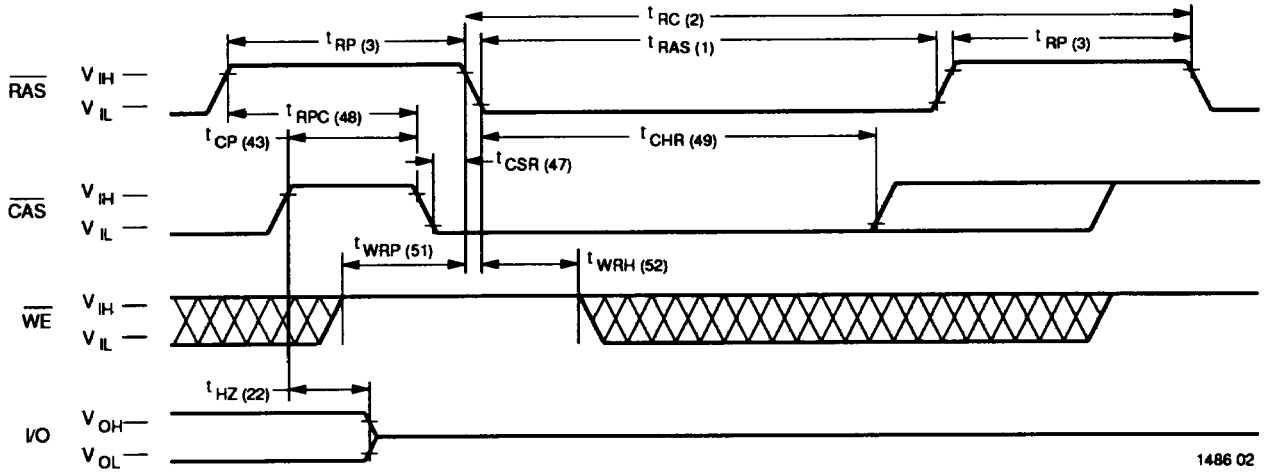

Waveforms of Hidden Refresh Cycle (Read)

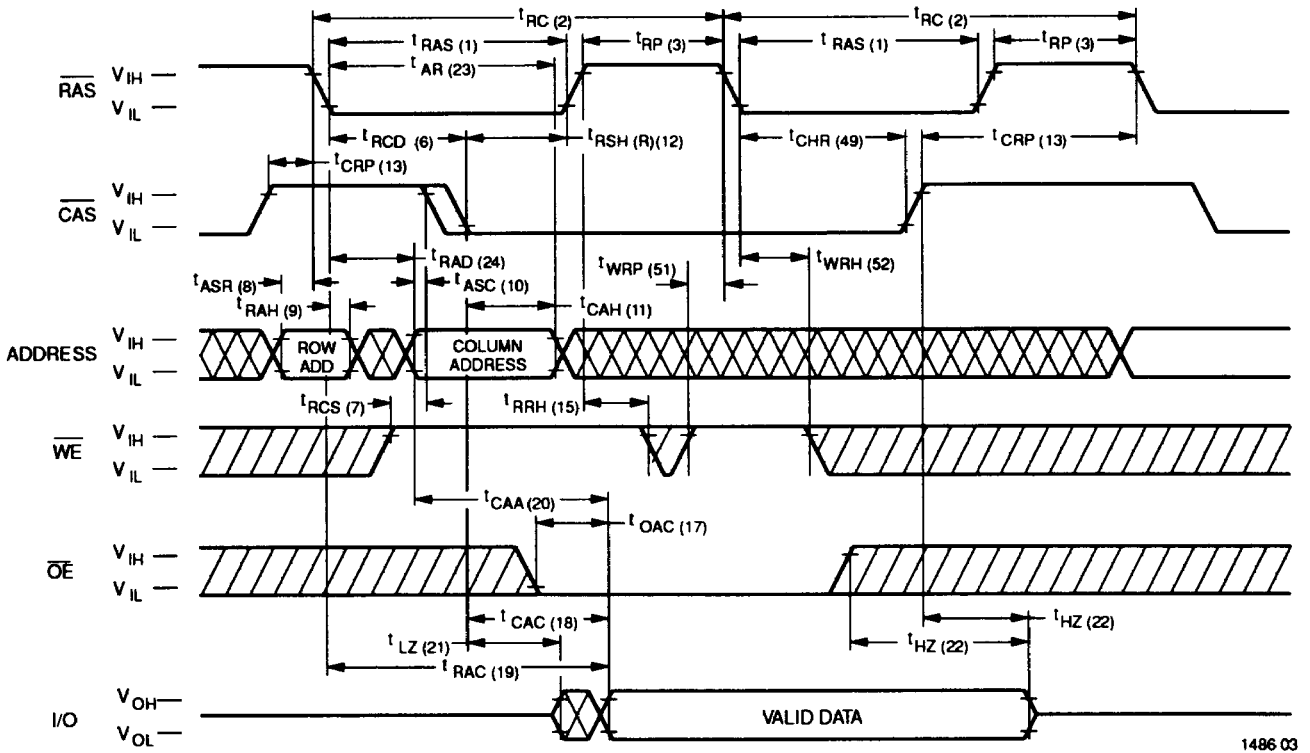

Waveforms of Hidden Refresh Cycle (Write)

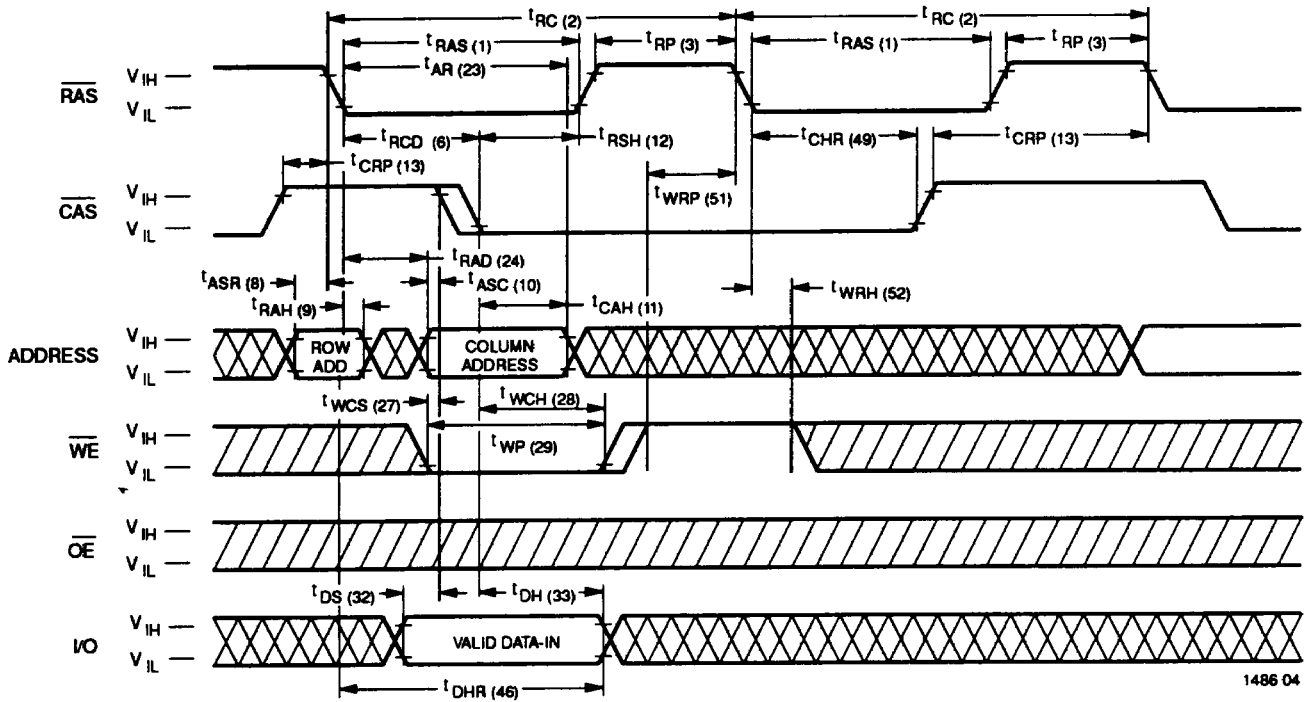

Test Mode Initiation Cycle

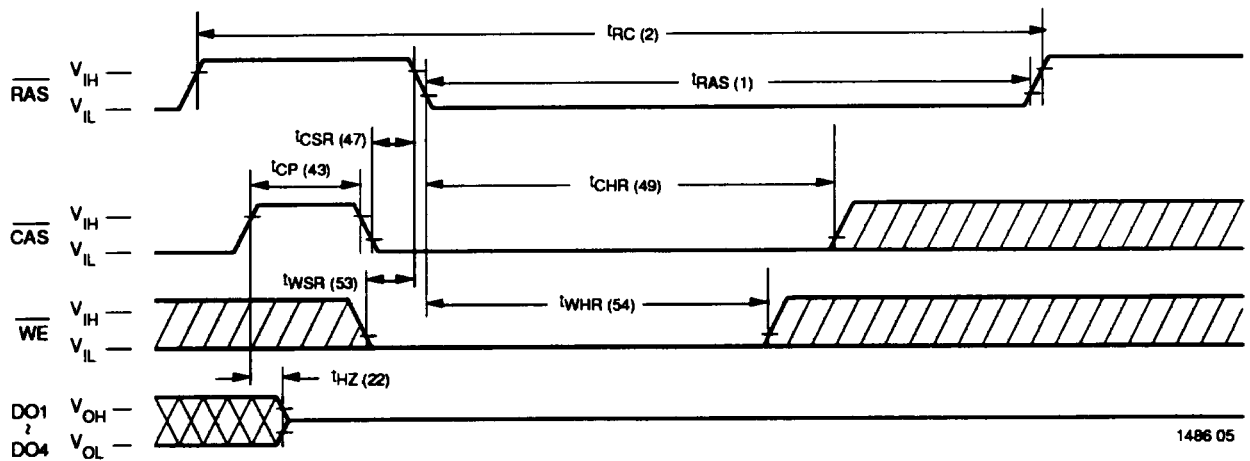

Waveforms of $\overline{\text{CAS}}$ -before- $\overline{\text{RAS}}$ Refresh Counter Test Cycle

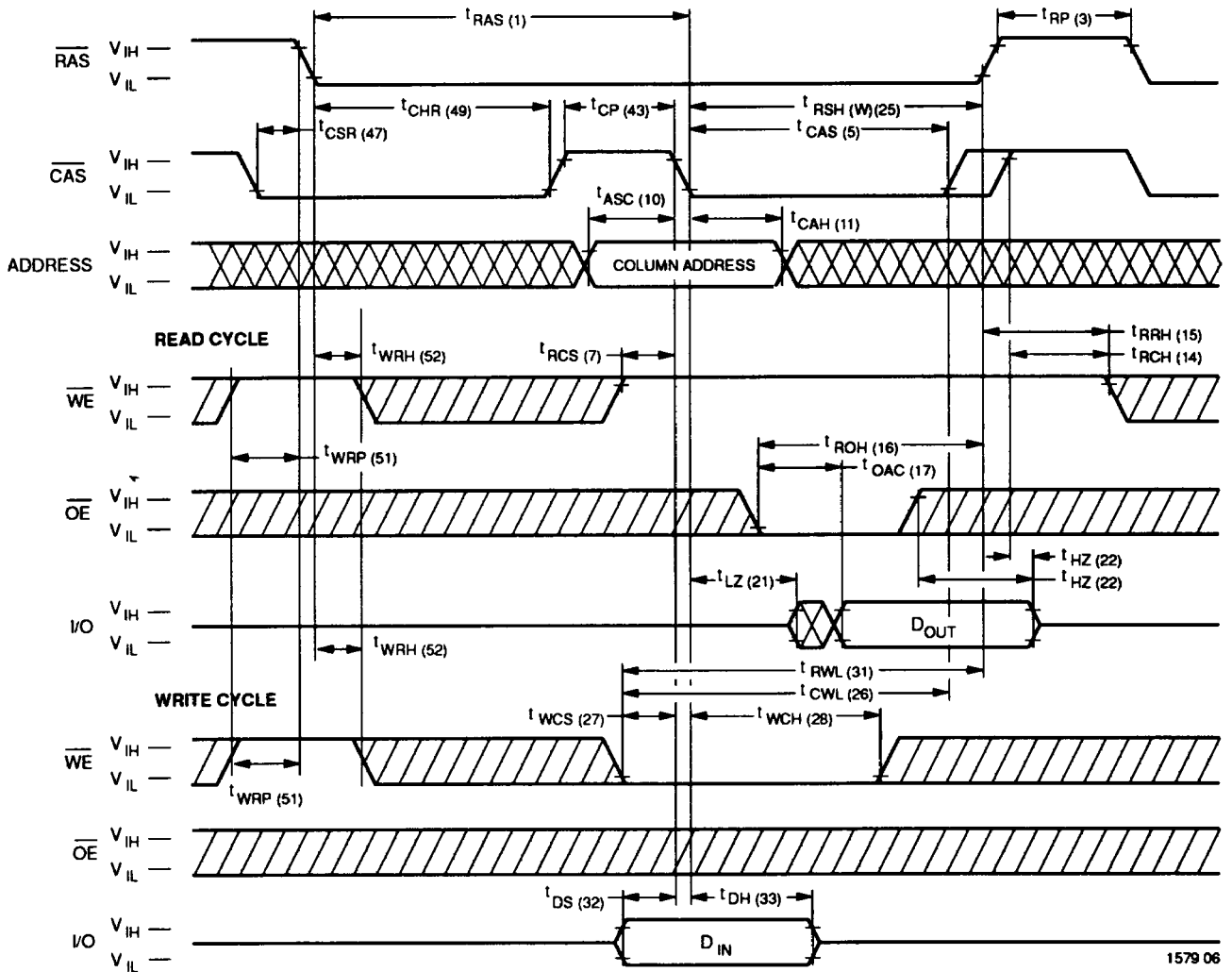

1579 06

Functional Description

The V53C404 is a CMOS dynamic RAM optimized for high data bandwidth, low power applications. It is functionally similar to a traditional dynamic RAM. The V53C404 reads and writes data by multiplexing an 20-bit address into a 10-bit row and a 10-bit column address. The row address is latched by the Row Address Strobe ($\overline{\text{RAS}}$). The column address "flows through" an internal address buffer and is latched by the Column Address Strobe ($\overline{\text{CAS}}$). Because access time is primarily dependent on a valid column address rather than the precise time that the $\overline{\text{CAS}}$ edge occurs, the delay time from $\overline{\text{RAS}}$ to $\overline{\text{CAS}}$ has little effect on the access time.

Memory Cycle

A memory cycle is initiated by bringing $\overline{\text{RAS}}$ low. Any memory cycle, once initiated, must not be ended or aborted before the minimum t_{RAS} time has expired. This ensures proper device operation and data integrity. A new cycle must not be initiated until the minimum precharge time $t_{\text{RP}}/t_{\text{CP}}$ has elapsed.

Read Cycle

A Read cycle is performed by holding the Write Enable ($\overline{\text{WE}}$) signal High during a $\overline{\text{RAS}}/\overline{\text{CAS}}$ operation. The column address must be held for a minimum specified by t_{AR} . Data Out becomes valid only when t_{OAC} , t_{RAC} , t_{CAA} and t_{CAC} are all satisfied. As a result, the access time is dependent on the timing relationships between these parameters. For example, the access time is limited by t_{CAA} when t_{RAC} , t_{CAC} and t_{OAC} are all satisfied.

Write Cycle

A Write Cycle is performed by taking $\overline{\text{WE}}$ and $\overline{\text{CAS}}$ low during a $\overline{\text{RAS}}$ operation. The column address is latched by $\overline{\text{CAS}}$. The Write Cycle can be $\overline{\text{WE}}$ controlled or $\overline{\text{CAS}}$ controlled depending on whether $\overline{\text{WE}}$ or $\overline{\text{CAS}}$ falls later. Consequently, the input data must be valid at or before the falling edge of $\overline{\text{WE}}$ or $\overline{\text{CAS}}$, whichever occurs last. In the $\overline{\text{CAS}}$ -controlled Write Cycle, when the leading edge of $\overline{\text{WE}}$ occurs prior to the $\overline{\text{CAS}}$ low transition, the I/O data pins will be in the High-Z state at the beginning of the Write function.

Ending the Write with $\overline{\text{RAS}}$ or $\overline{\text{CAS}}$ will maintain the output in the High-Z state.

In the $\overline{\text{WE}}$ controlled Write Cycle, $\overline{\text{OE}}$ must be in the high state and t_{OED} must be satisfied.

Refresh Cycle

To retain data, 1024 Refresh Cycles are required in each 16 ms period. There are two ways to refresh the memory:

1. By clocking each of the 1024 row addresses (A_9 through A_0) with $\overline{\text{RAS}}$ at least once every 16 ms. Any Read, Write, Read-Modify-Write or $\overline{\text{RAS}}$ -only cycle refreshes the addressed row.
2. Using a $\overline{\text{CAS}}$ -before- $\overline{\text{RAS}}$ Refresh Cycle. If $\overline{\text{CAS}}$ makes a transition from low to high to low after the previous cycle and before $\overline{\text{RAS}}$ falls, $\overline{\text{CAS}}$ -before- $\overline{\text{RAS}}$ refresh is activated. The V53C404 uses the output of an internal 10-bit counter as the source of row addresses and ignore external address inputs.

$\overline{\text{CAS}}$ -before- $\overline{\text{RAS}}$ is a "refresh-only" mode and no data access or device selection is allowed. Thus, the output remains in the High-Z state during the cycle. A $\overline{\text{CAS}}$ -before- $\overline{\text{RAS}}$ counter test mode is provided to ensure reliable operation of the internal refresh counter.

Data Retention Mode

The V53C404 offers a CMOS standby mode that is entered by causing the $\overline{\text{RAS}}$ clock to swing between a valid V_{IL} and an "extra high" V_{IH} within 0.2 V of V_{DD} . While the $\overline{\text{RAS}}$ clock is at the "extra high" level, the V53C404 power consumption is reduced to the low I_{DD6} level. Overall I_{DD} consumption when operating in this mode can be calculated as follows:

$$I = \frac{(t_{\text{RC}}) \times (I_{\text{DD1}}) + (t_{\text{RX}} - t_{\text{RC}}) \times (I_{\text{DD6}})}{t_{\text{RX}}}$$

Where: t_{RC} = Refresh Cycle Time
 t_{RX} = Refresh Interval / 1024

Fast Page Mode Operation

Fast Page Mode operation permits all 1024 columns within a selected row of the device to be randomly accessed at a high data rate. Maintaining $\overline{\text{RAS}}$ low while performing successive $\overline{\text{CAS}}$ cycles retains the row address internally and eliminates the need to reapply it for each cycle. The column address buffer acts as a transparent or flow-through latch while $\overline{\text{CAS}}$ is high. Thus, access begins from the occurrence of a valid column address rather than from the falling edge of $\overline{\text{CAS}}$, eliminating t_{ASC} and t_{T} from the critical timing path. $\overline{\text{CAS}}$ latches the address into the column address buffer and acts as an output enable. During Fast Page Mode operation, Read, Write, Read-Modify-Write or Read-Write-Read cycles are possible at random addresses within a row. Following the initial entry cycle into Fast Page Mode, access is t_{CAA} or t_{CAP} controlled. If the column address is valid prior to the rising edge of $\overline{\text{CAS}}$, the access time is referenced to the $\overline{\text{CAS}}$ rising edge and is specified by t_{CAP} . If the column address is valid after the rising $\overline{\text{CAS}}$ edge, access is timed from the occurrence of a valid address and is specified by t_{CAA} . In both cases, the falling edge of $\overline{\text{CAS}}$ latches the address and enables the output.

Fast Page Mode provides a sustained data rate of 20 MHz for applications that require high data rates such as bit-mapped graphics or high-speed signal processing. The following equation can be used to calculate the maximum data rate:

$$\text{Data Rate} = \frac{1024}{t_{\text{RC}} + 1023 \times t_{\text{PC}}}$$

Data Output Operation

The V53C404 Input/Output is controlled by $\overline{\text{OE}}$, $\overline{\text{CAS}}$, $\overline{\text{WE}}$ and $\overline{\text{RAS}}$. A $\overline{\text{RAS}}$ low transition enables the transfer of data to and from the selected row address in the Memory Array. A $\overline{\text{RAS}}$ high transition disables data transfer and latches the output data if the output is enabled. After a memory cycle is initiated with a $\overline{\text{RAS}}$ low transition, a $\overline{\text{CAS}}$ low transition or $\overline{\text{CAS}}$ low level enables the internal I/O path. A $\overline{\text{CAS}}$ high transition or a $\overline{\text{CAS}}$ high level disables the I/O path and the output driver if it is enabled. A $\overline{\text{CAS}}$ low transition while $\overline{\text{RAS}}$ is high has no effect on the I/O data path or on the output drivers. The output drivers, when otherwise enabled, can be disabled by holding

$\overline{\text{OE}}$ high. The $\overline{\text{OE}}$ signal has no effect on any data stored in the output latches. A $\overline{\text{WE}}$ low level can also disable the output drivers when $\overline{\text{CAS}}$ is low. During a Write cycle, if $\overline{\text{WE}}$ goes low at a time in relationship to $\overline{\text{CAS}}$ that would normally cause the outputs to be active, it is necessary to use $\overline{\text{OE}}$ to disable the output drivers prior to the $\overline{\text{WE}}$ low transition to allow Data In Setup Time (t_{DS}) to be satisfied.

Power-On

After application of the V_{DD} supply, an initial pause of 200 μs is required followed by a minimum of 8 initialization cycles (any combination of cycles containing a $\overline{\text{RAS}}$ clock). Eight initialization cycles are required after extended periods of bias without clocks (greater than the Refresh Interval).

During Power-On, the V_{DD} current requirement of the V53C404 is dependent on the input levels of $\overline{\text{RAS}}$ and $\overline{\text{CAS}}$. If $\overline{\text{RAS}}$ is low during Power-On, the device will go into an active cycle and I_{DD} will exhibit current transients. It is recommended that $\overline{\text{RAS}}$ and $\overline{\text{CAS}}$ track with V_{DD} or be held at a valid V_{IH} during Power-On to avoid current surges.

Table 1. Vitelic V53C404 Data Output Operation for Various Cycle Types

Cycle Type	I/O State
Read Cycles	Data from Addressed Memory Cell
$\overline{\text{CAS}}$ -Controlled Write Cycle (Early Write)	High-Z
$\overline{\text{WE}}$ -Controlled Write Cycle (Late Write)	$\overline{\text{OE}}$ Controlled. High $\overline{\text{OE}} = \text{High-Z I/Os}$
Read-Modify-Write Cycles	Data from Addressed Memory Cell
Fast Page Mode Read	Data from Addressed Memory Cell
Fast Page Mode Write Cycle (Early Write)	High-Z
Fast Page Mode Read-Modify-Write Cycle	Data from Addressed Memory Cell
$\overline{\text{RAS}}$ -only Refresh	High-Z
$\overline{\text{CAS}}$ -before- $\overline{\text{RAS}}$ Refresh Cycle	Data remains as in previous cycle
$\overline{\text{CAS}}$ -only Cycles	High-Z

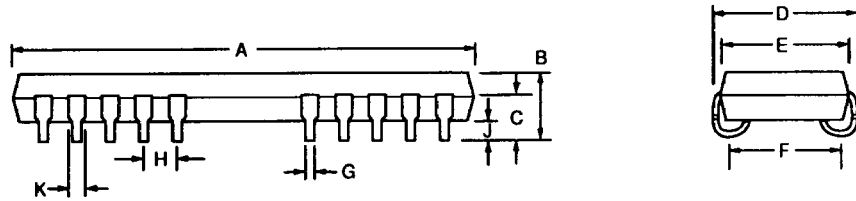

26/20-pin SOJ

Dimension	Inches	Millimeters
A	0.672/0.684	17.069/17.374
B	0.125/0.135	3.175/3.429
C	0.082/0.093	2.083/2.362
D	0.332/0.342	8.433/8.687
E	0.296/0.304	7.518/7.722
F	0.255/0.275	6.477/6.985
G	0.018 Typ.	0.457 Typ.
H	0.05 Typ.	1.270 Typ.
J	0.026 Min.	0.660 Min.
K	0.028 Typ.	0.711 Typ.



U.S.A.

VITELIC SEMICONDUCTOR
3910 NORTH FIRST STREET
SAN JOSE, CA 95134
PHONE: 408-433-6000
FAX: 408-433-0185

TAIWAN

VITELIC CORP.
133, MINSHENG E. RD.,
SECTION III, 7B
TAIPEI, TAIWAN, R.O.C.
PHONE: 011-886-2-718-1369
FAX: 011-886-2-718-1362

VITELIC TAIWAN CORP.
1 R&D ROAD I
SCIENCE BASED IND. PARK
HSIN CHU, TAIWAN, R.O.C.
PHONE: 011-886-35-770055
FAX: 011-886-35-776520

JAPAN

VITELIC JAPAN CORP.
NIHON SEIMEI KAWASAKI
BLDG., 8TH FL.
1-1 MINAMI-CHO KAWASAKI-KU
KAWASAKI-SHI KANAGAWA 210
JAPAN
PHONE: 011-04-4-246-3021
FAX: 011-04-4-246-3029

HONG KONG

VITELIC (HONG KONG) LIMITED
19 DAI FU STREET
TAIPO INDUSTRIAL ESTATE
TAIPO, NT, HONG KONG
PHONE: 011-852-665-4883
FAX: 011-852-664-7535

KOREA

VITELIC CORP.
RM. 309, BEUK-EUN BLDG.
1339-1 SEOCHO-DONG,
SEOCHO-KU
SEOUL, KOREA
PHONE: 011-82-2-553-3385
FAX: 011-82-2-553-3675

VITELIC U.S. SALES OFFICES

NORTHWESTERN

VITELIC SEMICONDUCTOR
3910 NORTH FIRST STREET
SAN JOSE, CA 95134
PHONE: 408-433-6000
FAX: 408-433-0185

SOUTHWESTERN

VITELIC SEMICONDUCTOR
SUITE 200
5150 E. PACIFIC COAST HWY.
LONG BEACH, CA 90804
PHONE: 213-498-3314
FAX: 213-597-2174

EASTERN/MIDWESTERN

VITELIC SEMICONDUCTOR
SUITE 203
619 SEVERN AVENUE
ANNAPOLIS, MD 21403
PHONE: 301-267-9616
FAX: 301-267-7411
or: 301-268-9081

VICMOS is a trademark of VITELIC
© Copyright 1991, Vitelic Corporation

9/91
Printed in U.S.A.

The information in this document is subject to change without notice.

VITELIC makes no commitment to update or keep current the information contained in this document. No part of this document may be copied or reproduced in any form or by any means without the prior written consent of VITELIC.

VITELIC subjects its products to normal quality control sampling techniques which are intended to provide an assurance of high quality products suitable for usual commercial applications. VITELIC does not do testing appropriate to provide 100% product quality assurance and does not assume any liability for consequential or incidental arising from any use of its products. If such products are to be used in applications in which personal injury might occur from failure, purchaser must do its own quality assurance testing appropriate to such applications.

