

Series DSX	ENVIRONMENTAL SIZE 3 RECEPTACLE CONNECTOR	Issue:	Page
	6CU - 106 - 106 INSERTS SPL : AIRBUS SA / E0729H3--A	Dec. 12, 2017	1/2

CODE : black area = key		RADIALL CONNECTOR P/N	AIRBUS SA. P/N
WITHOUT CODE	SEE NOTE 1	DSXE3RX6CUPX106SX106S37	ASNE0729H3ZZA
04		DSXE3RX6CUPX106SX106S3704	ASNE0729H304A

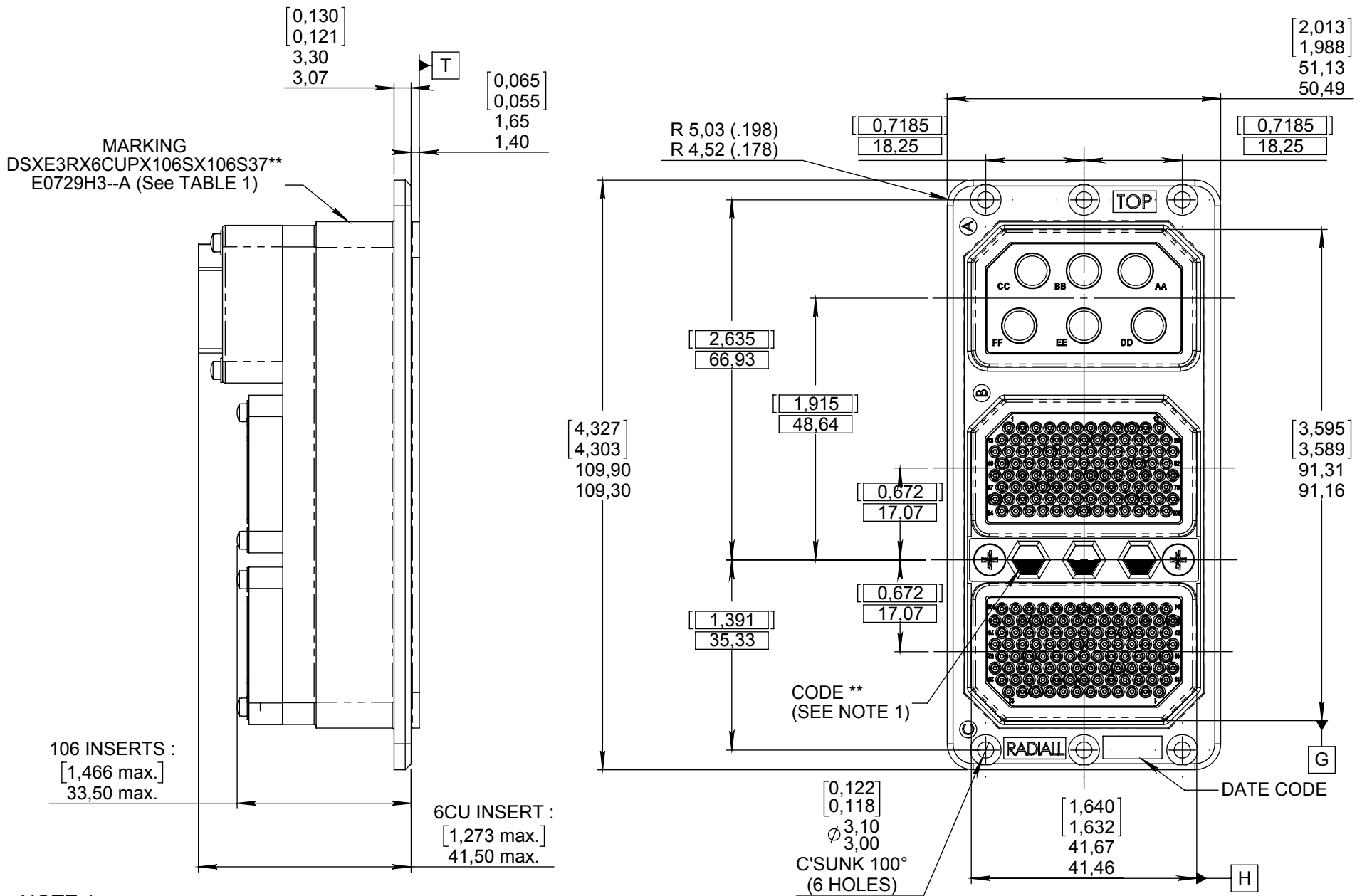

NOTE 1 :
(**) REPRESENTS THE POLARIZATION CODE AND IS CONFORM WITH SAE AS81659 STANDARD
WITHOUT POLARIZATION CODE, THE CONNECTOR IS DELIVERED WITH POLARIZATION HARDWARE UNASSEMBLED
WITH CODE 00 POLARIZATION, THE CONNECTOR IS DELIVERED WITHOUT POLARIZATION HARDWARE

FOR INFO ONLY:
FOR SOCKET AND PIN CONTACTS
PROTRUDING FROM THE INSERTS

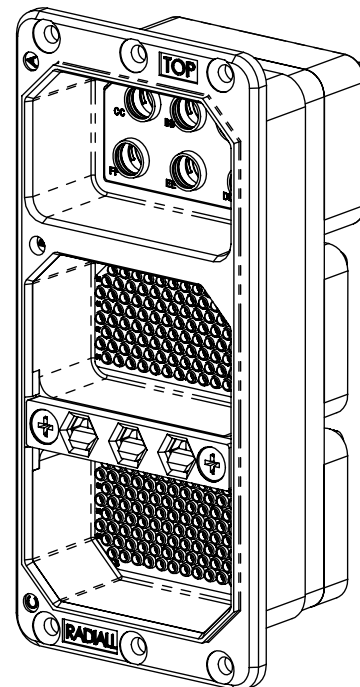

DIMENSIONS : mm (inch are given for information only)

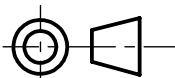

Estimated weight : 198 g

CREATION				
PEN: /				
NOM: MOUTAULT W.				
DATE: Dec. 12, 2017				
APPR.: LEGENDRE T.				
Issue	Revisions	Name	Approved	

This document contains proprietary information and such information shall not be disclosed to any third party for any purpose whatsoever or used for manufacturing purposes without prior written agreement from RADIALL. This information is given as an indication. In the continual goal to improve our products, we reserve the right to make any modifications judged necessary.

4112_9311

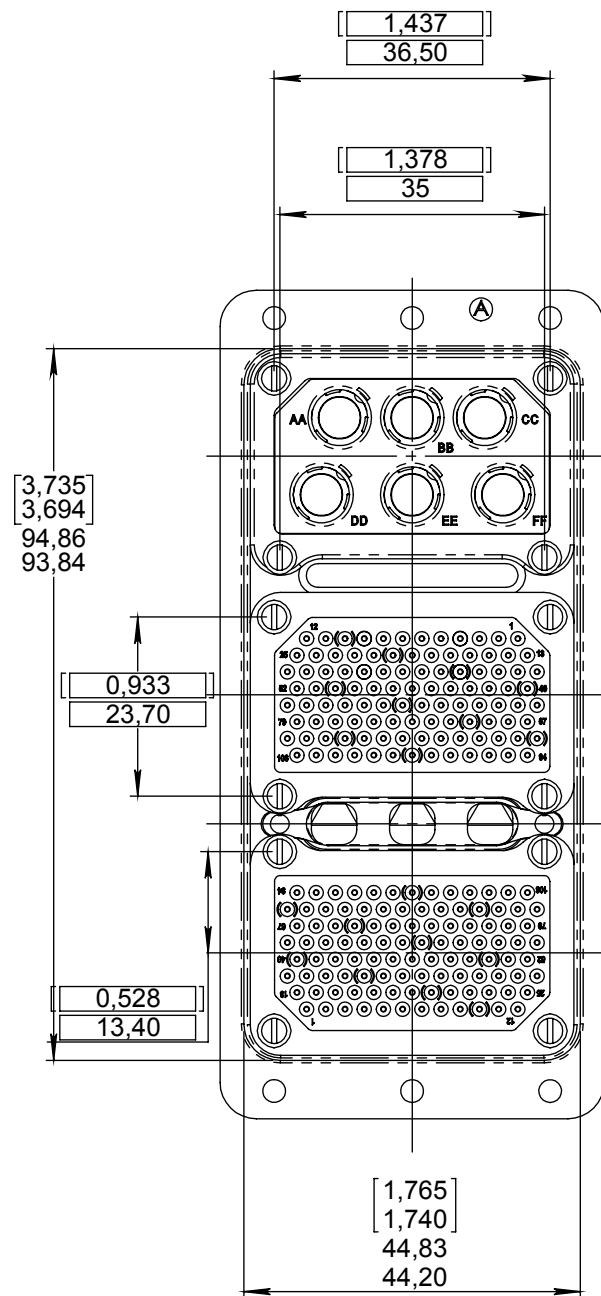

MATERIAL:

- SHELL : DIE CAST ALUMINUM ALLOY PER SAE AMS-QQ-A-591
- INSERT RETAINING PLATE : DIE CAST ALUMINUM ALLOY PER SAE AMS-QQ-A-591
- 106 INSERTS : THERMOSETTING MOLDED COMPOUND PER ASTM D 5948
- 6CU INSERT : ALUMINUM ALLOY PER SAE AMS-QQ-A-250
- GROMMET AND INTERFACIAL SEAL : FLUOROSILICONE ELASTOMER PER SAE AMS-R-25988
- CONTACT RETENTION CLIPS : BERYLLIUM COPPER PER ASTM B 194
- POLARIZING RETENTION PLATE : DIE CAST ALUMINUM ALLOY PER SAE AMS-QQ-A-591
- POLARIZING KEYS : ZINC ALLOY PER ASTM B 86
- SCREWS AND WASHERS : CORROSION RESISTANT MATERIAL
- DUST CAPS : POLYETHYLEN

FINISH:

- SHELL : ELECTROLESS NICKEL PER SAE AMS-2404
- INSERT RETAINING PLATES : BLUE EPOXY PAINT
- POLARIZING RETENTION PLATE : ELECTROLESS NICKEL PER SAE AMS-2404, BLUE EPOXY PAINTED
- POLARIZING KEYS : ELECTROLESS NICKEL PER SAE AMS-2404

106 INSERTS FOR SIZE 22 REAR RELEASE REAR REMOVABLE CRIMP SOCKET CONTACTS

ON (6CU) INSERT QUADRAX CAVITIES ARE GROUNDED TO SHELL

SIZE 8 QUADRAX REAR RELEASE REAR REMOVABLE CRIMP PIN CONTACTS MUST BE ORDER SEPARATLY

THE CONNECTOR IS DELIVERED WITH THE POLARIZING SYSTEM PER CODE (SEE TABLE PAGE 1/2 PER P/N)

CONNECTOR FITTED WITHOUT CONTACT :

- MARKING : CONNECTOR MUST BE MARKED WITH : DSXE3RX6CUPX106SX106S37** + DATE CODE + E0729H3--A (***) SEE NOTE 1 (PAGE 1/2) AND (--) SEE TABLE (PAGE 1/2)
- COVER P/N : 610805 (INSTALLED)
- INDIVIDUAL PACKAGING

This document contains proprietary information and such information shall not be disclosed to any third party for any purpose whatsoever or used for manufacturing purposes without prior written agreement from RADIALL. This information is given as an indication. In the continual goal to improve our products, we reserve the right to make any modifications judged necessary.

4112_9311