



# IL440

## Triac Predriver Non-Zero Crossing Optocoupler

### FEATURES

- 400 and 600 V Blocking Voltage
- 5.0 mA Maximum Trigger Current
- Isolation Voltage, 5300 V<sub>RMS</sub>, t=1.0 sec.
- Isolation Materials per UL94
- Pin Compatible with Motorola Optocouplers

IL440-1	MOC 3051
IL440-2	MOC 3052
IL440-3	—
IL440-4	MOC 3021
IL440-5	MOC 3022
IL440-6	MOC 3023

- VDE Approval #0884 Available with Option 1

### APPLICATIONS

- High Current Triac Driver
- Solid State Relays
- Switch Small AC Loads

### Maximum Ratings

#### Emitter

Reverse Voltage .....	5.0V
Forward Current .....	60 mA
Surge Current (P.W.<10 μs).....	3.0 A
Power Dissipation.....	100 mW
Junction Temperature.....	100°C

#### Detector

Peak Off-state Voltage	
IL440-1, 2, 3 .....	600 V
IL440-4, 5, 6 .....	400 V
On-state RMS Current .....	100 mA
Peak Surge Current (t <sub>p</sub> ≤10 ms).....	1.2 A
Peak On-state Current (t <sub>p</sub> /T=0.01≤100 μs) .....	2.0 A
Power Dissipation.....	300 mW
Junction Temperature.....	125°C

#### Package

Isolation Voltage, 1.0 sec. ....	5300 V <sub>RMS</sub>
per Standard Climate 23°C/50% RH, DIN 50014	
Creepage .....	≥7.0 mm
Clearance .....	≥7.0 mm
Isolation Resistance	
V <sub>IO</sub> =500 V, T <sub>A</sub> =25°C .....	≥10 <sup>12</sup> Ω
V <sub>IO</sub> =500 V, T <sub>A</sub> =100°C .....	≥10 <sup>11</sup> Ω
Total Power Dissipation, T <sub>A</sub> =25°C .....	330 mW
Storage Temperature Range .....	-55°C to +125°C
Operating Temperature Range.....	-40°C to +100°C
Junction Temperature.....	100°C
Lead Soldering Temperature	
(2.0 mm from case, t<10 s.) .....	260°C

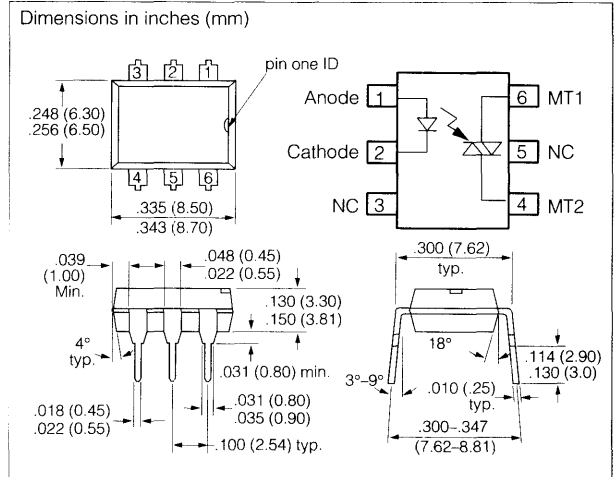

### DESCRIPTION

The IL440-X consists of a GaAs infrared emitter optically coupled to a silicon planar triac chip with a non-zero crossing network. The two semi-conductors are assembled in a 6 pin dual-in-line plastic package. The output detector IL440-1, 2, 3 is capable of blocking up to 600 volts which permits control of off-line voltages up to 240 VAC. The IL440 can handle currents up to 100 mA<sub>RMS</sub>.

### Maximum Safety Ratings

This device is used for protective separation against electrical shock within the maximum safety ratings. This must be ensured by protective circuits in the applications.

Parameter	Symbol	Max.	Unit	Test Condition
<b>Emitter</b>				
Forward Current	I <sub>SI</sub>	130	mA	—
<b>Detector</b>				
Power Dissipation	P <sub>SI</sub>	300	mW	T <sub>A</sub> ≥25°C

**Electrical Characteristics,  $T_A=25^\circ\text{C}$** 

Parameter	Symbol	Min.	Typ.	Max.	Unit	Test Condition
<b>Emitter</b>						
Forward Voltage	$V_F$	—	1.25	1.6	V	$I_F=50\text{ mA}$
Breakdown Voltage	$V_{BR}$	5.0	—	—	V	$I_R=10\ \mu\text{A}$
Junction Capacitance	$C_J$	—	50	—	pF	$V_R=0\text{ V}$ , $f=1.0\text{ MHz}$
<b>Detector</b>						
Off-state Output Terminal Voltage (see Table 1.)						
Peak On-state Voltage	$V_{TM}$	—	1.5	3.0	V	$I_{TM}=100\text{ mA}$ , $I_{FT}=30\text{ mA}$
Critical Rate of Rise of Off-state Voltage	$(dv/dt)_{cr}$	—	50	—	V/ $\mu\text{s}$	$I_F=0$ , $V_S=240\text{ V}_{RMS}$
	$(dv/dt)_{crq}$	0.13	0.25	—	V/ $\mu\text{s}$	$I_F=30\text{ mA}$ , $V_S=60\text{ V}_{RMS}$
<b>Coupled Device</b>						
Holding Current	$I_H$	—	1.0	—	mA	$I_F\geq 10\text{ mA}$ , $V_S\geq 3.0\text{ V}$

**Table 1.  $I_{FT}$  and Blocking Voltage Selection<sup>(1)</sup>**

Bin number	BV (Volts) Max @ $I_{DRM}=500\text{ nA}$	$I_{FT}$ Max @ $V_T=6\text{ V}$ , $R_L=150\ \Omega$
IL440-1	600	15
IL440-2	600	10
IL440-3	600	5.0
IL440-4	400	15
IL440-5	400	10
IL440-6	400	5.0

1. Test voltage must be applied within  $dV/dt$  rating of 0.13 V/ $\mu\text{sec}$ .