

GP1200FSS12S

POWERLINE N-CHANNEL IGBT MODULE

APPLICATIONS

- High Power Switching.
- Motor Control.
- UPS.
- AC And DC Servo Drive Amplifiers.

FEATURES

- n - Channel.
- Enhancement Mode.
- High Input Impedance.
- High Switching Speed.
- Latch-Free Operation.
- Low Forward Voltage Drop.
- Isolated Base.
- Short Circuit Capability (10μs).

CIRCUIT

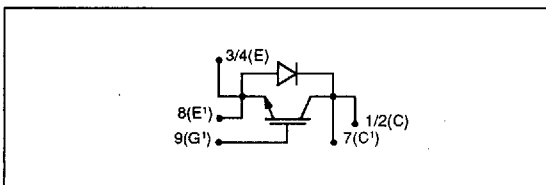

Fig.1 Single switch circuit diagram

TYPICAL KEY PARAMETERS

V_{CES}	1200V
$V_{CE(sat)}$	2.8V
$I_C(CONT)$	1200A
$I_C(PK)$	2400A
t_r	190ns
t_f	840ns

PACKAGE OUTLINE

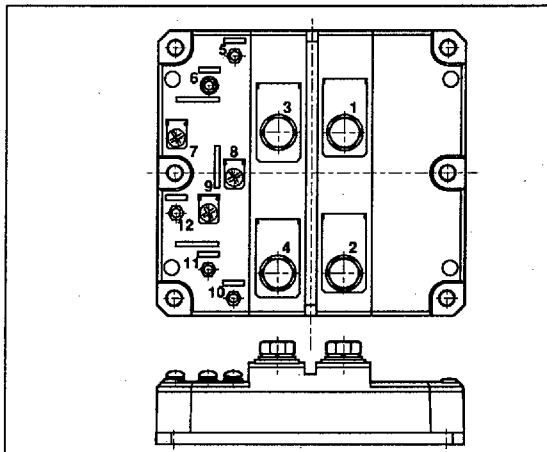

Fig.2

Outline type code: F. See package details for further information.

RATINGS

$T_{case} = 25^{\circ}C$ unless stated otherwise.				
Symbol	Parameter	Test Conditions	Max.	Units
V_{CES}	Collector-emitter voltage	$V_{GE} = 0V$	1200	V
V_{GES}	Gate-emitter voltage		±20	V
I_C	Collector current	DC, $T_{case} = 75^{\circ}C$	1200	A
$I_{C(PK)}$		1ms, $T_{case} = 75^{\circ}C$	2400	A
P_{max}	Maximum power dissipation		7500	W
V_{isol}	Isolation voltage	Commoned terminals to base plate. AC RMS, 1 min, 50Hz	2500	V

THERMAL AND MECHANICAL RATINGS

Symbol	Parameter	Conditions	Min.	Max.	Units
$R_{\theta(j-c)}$	Thermal resistance	DC junction to case	-	0.016	°C/W
$R_{\theta(j-h)}$	Thermal resistance - Case to heatsink	Mounting torque 5Nm (with mounting grease)	-	0.002	°C/W
T_j	Junction temperature	-	-	150	°C
T_{stg}	Storage temperature range	-	-40	150	°C
-	Screw torque (mounting)	-	-	6.0	Nm

DC ELECTRICAL CHARACTERISTICS

$T_{case} = 25^\circ\text{C}$ unless stated otherwise.						
Symbol	Parameter	Conditions	Min.	Typ.	Max.	Units
I_{CES}	Collector cut-off current	$V_{GE} = 0V, V_{CE} = V_{CES}$	-	-	12	mA
I_{GES}	Gate leakage current	$V_{GE} = \pm 20V, V_{CE} = 0V$	-	-	± 6	μA
$V_{GE(TH)}$	Gate threshold voltage	$I_C = 60\text{mA}, V_{GE} = V_{CE}$	4	-	7.5	V
$V_{CE(SAT)}$	Collector-emitter saturation voltage	$V_{GE} = 15V, I_C = 1200\text{A}$	-	2.8	3.6	V
		$V_{GE} = 15V, I_C = 1200\text{A}, T_{case} = 125^\circ\text{C}$	-	3.0	3.6	V

DIODE DC CHARACTERISTICS

$T_{case} = 25^\circ\text{C}$ unless stated otherwise.						
Symbol	Parameter	Conditions	Min.	Typ.	Max.	Units
I_F	Diode forward current	DC, $T_{case} = 75^\circ\text{C}$	-	-	840	A
I_{FM}	Diode maximum forward current	$T_{case} = 75^\circ\text{C}, t_p = 1\text{ms}$	-	-	2400	A
V_F	Diode forward voltage	$I_F = 1200\text{A}$	-	2.25	2.7	V
$R_{\theta(j-c)}$	Thermal resistance	DC junction to case	-	-	0.057	°C/W

AC ELECTRICAL CHARACTERISTICS

Symbol	Parameter	Conditions	Min.	Typ.	Max.	Units
C_{iss}	Input capacitance	$V_{CE} = 25V, V_{GE} = 0V, f = 1\text{MHz}$	-	162000	-	pF
C_{oss}	Output capacitance	$V_{CE} = 25V, V_{GE} = 0V, f = 1\text{MHz}$	-	9000	-	pF
C_{res}	Reverse transfer capacitance	$V_{CE} = 25V, V_{GE} = 0V, f = 1\text{MHz}$	-	10800	-	pF

GP1200FSS12S

INDUCTIVE SWITCHING CHARACTERISTICS

For definition of switching waveforms, refer to figures 6 and 7 shown in application note AN4504 IGBT Ratings and Characteristics.

T _{case} = 125°C unless stated otherwise.						
Symbol	Parameter	Conditions	Min.	Typ.	Max.	Units
t _{d(off)}	Turn-off delay time	$I_C = 1200A,$ $V_{GE} = \pm 15V,$ $V_{CE} = 50\% V_{CES},$ $R_{G(ON)} = R_{G(OFF)} = 0.5\Omega$	-	620	-	ns
t _f	Fall time		-	840	-	ns
E _{OFF}	Turn-off energy loss		-	336	-	mJ
t _{d(on)}	Turn-on delay time		-	750	-	ns
t _r	Rise time		-	190	-	ns
E _{ON}	Turn-on energy loss		-	336	-	mJ

DIODE DYNAMIC CHARACTERISTICS (INDUCTIVE)

T _{case} = 125°C unless stated otherwise.						
Symbol	Parameter	Conditions	Min.	Typ.	Max.	Units
t _{rr}	Reverse recovery time	T _{case} = 25°C, I _F = 1200A	-	110	-	ns
Q _{rr}	Reverse recovery charge	V _R = 50%V _{CES} , dI _F /dt = 3600A/μs	-	48	-	μC
t _{rr}	Reverse recovery time	I _F = 1200A	-	240	-	ns
Q _{rr}	Reverse recovery charge	V _R = 50%V _{CES} , dI _F /dt = 3600A/μs	-	144	-	μC

CURVES

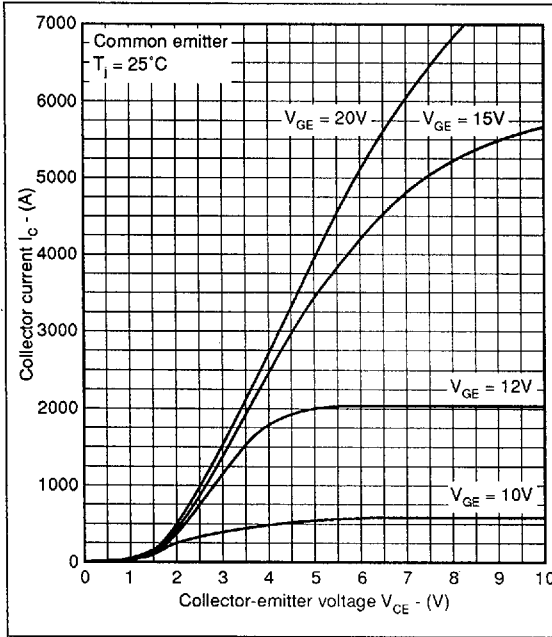

Fig.3 Typical output characteristics @ 25°C

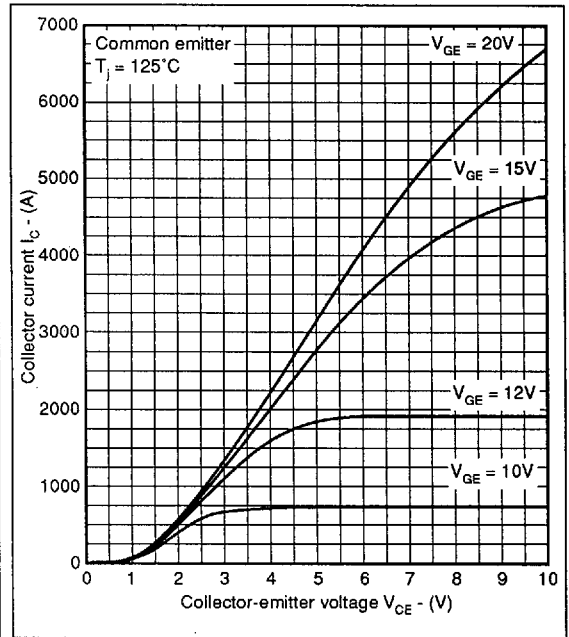

Fig.4 Typical output characteristics @ 125°C

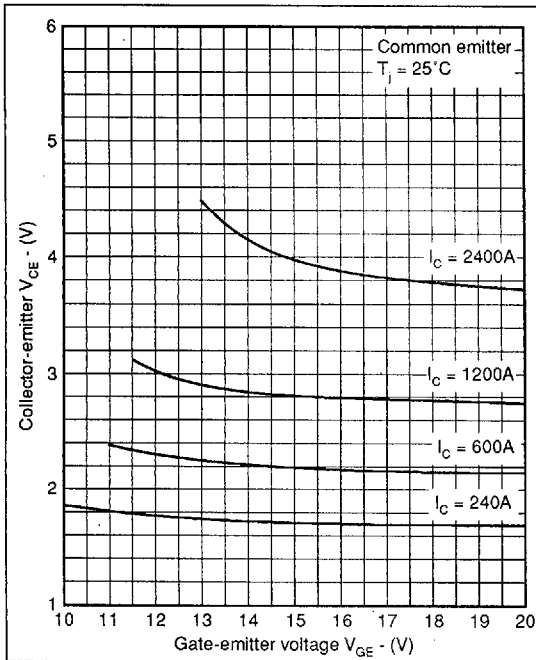

Fig.5 Typical transfer characteristics @ 25°C

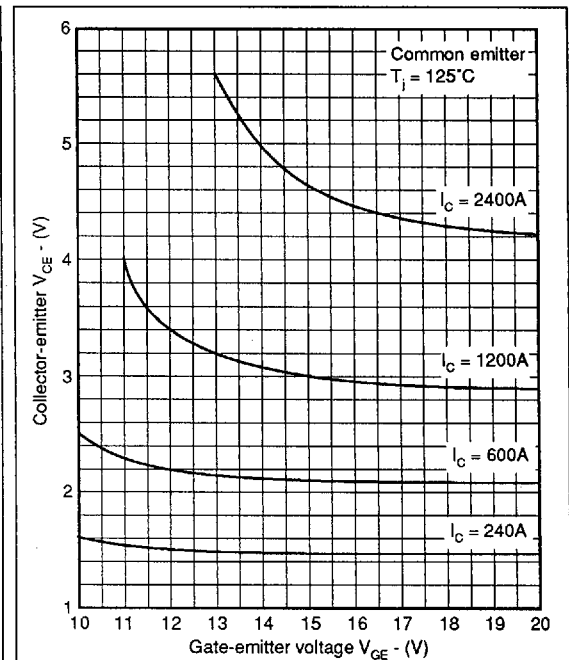

Fig.6 Typical transfer characteristics @ 125°C

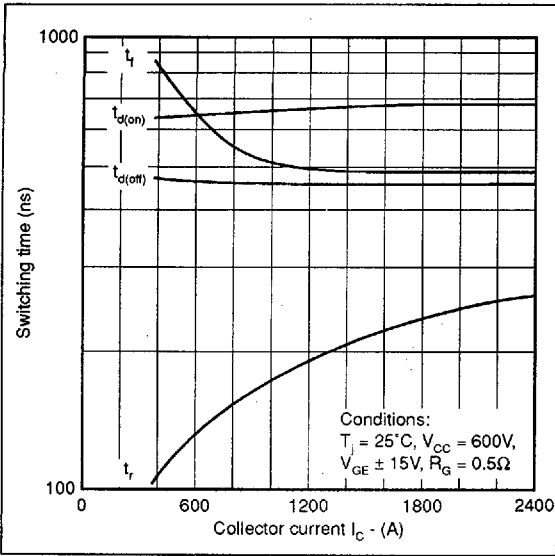

Fig.7 Typical switching time vs I_C @ 25°C

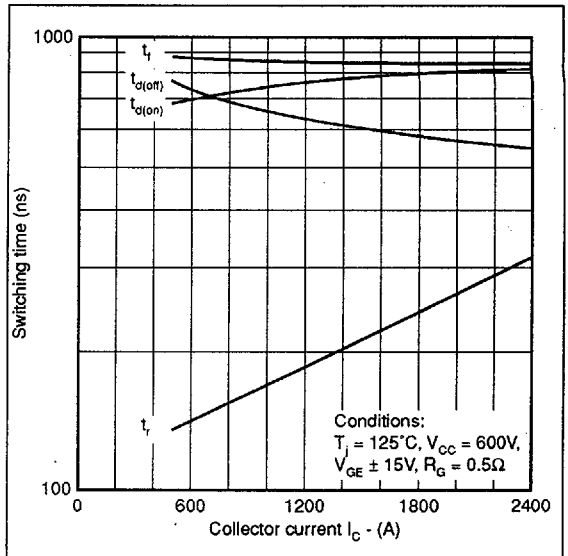

Fig.8 Typical switching time vs I_C @ 125°C

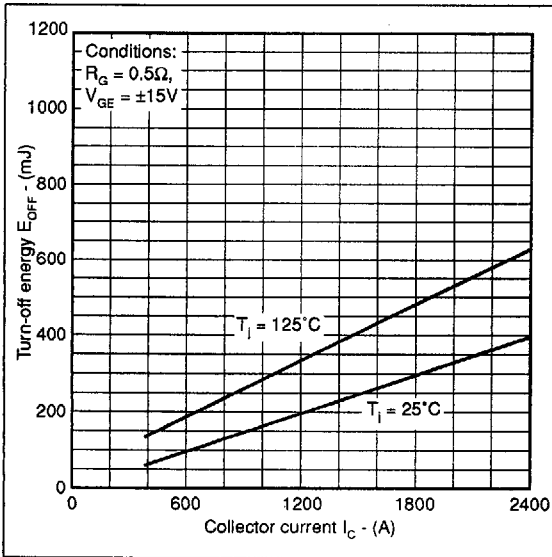

Fig.9 Typical turn-off losses

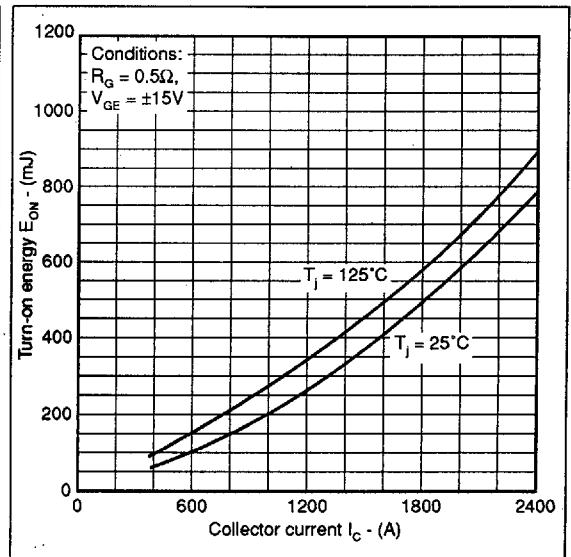

Fig.10 Typical turn-on losses

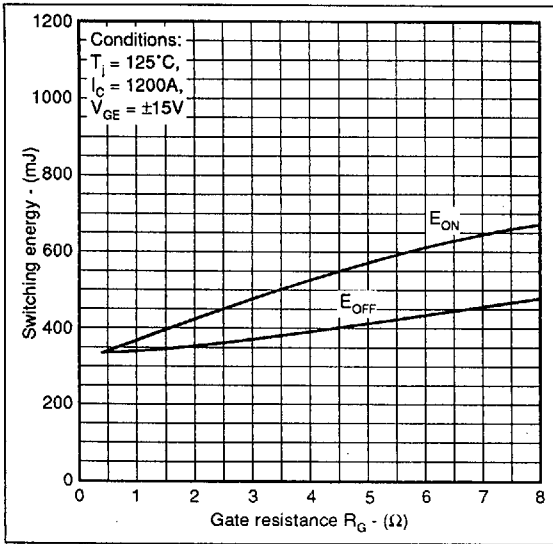

Fig.11 Typical switching energy @125°C

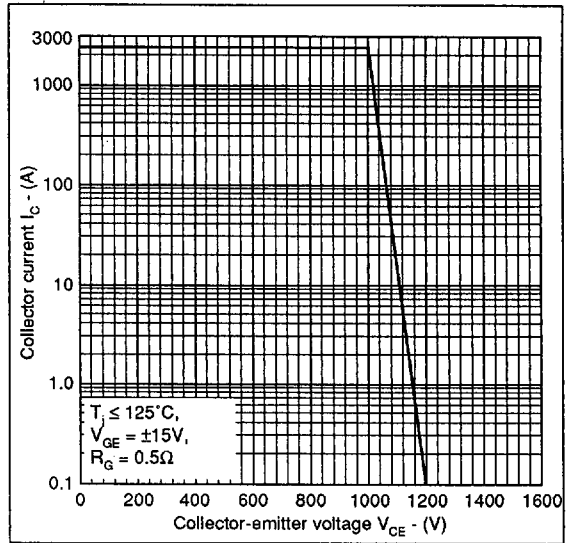

Fig.12 Reverse bias safe operating area

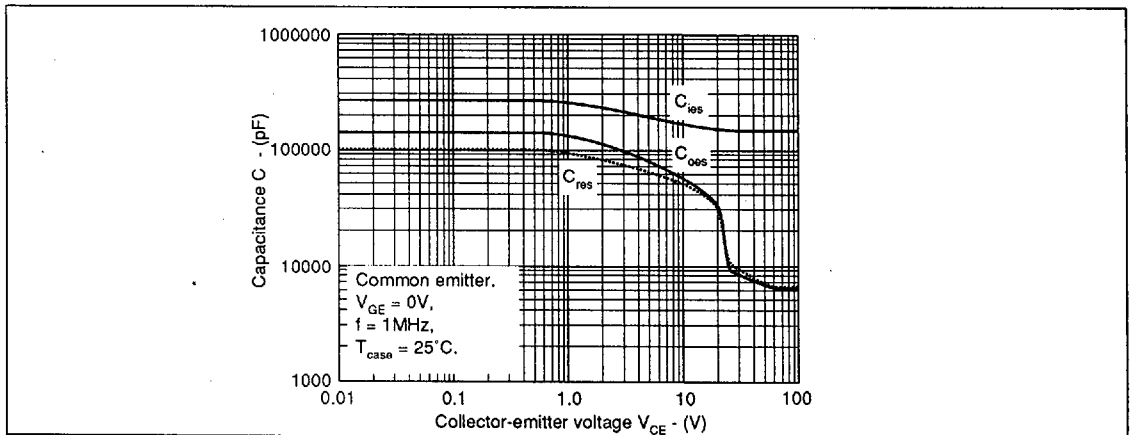

Fig.13 Typical capacitance

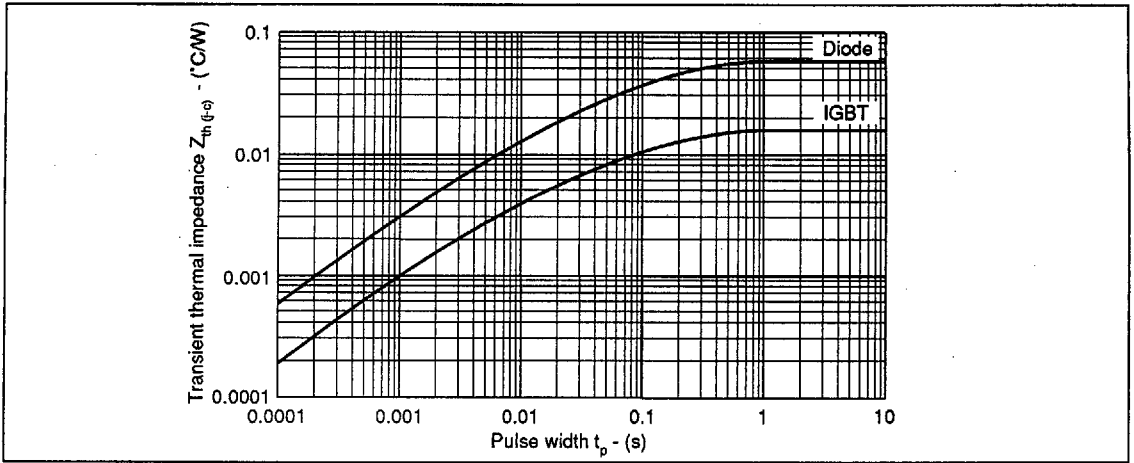

Fig.14 Transient thermal impedance

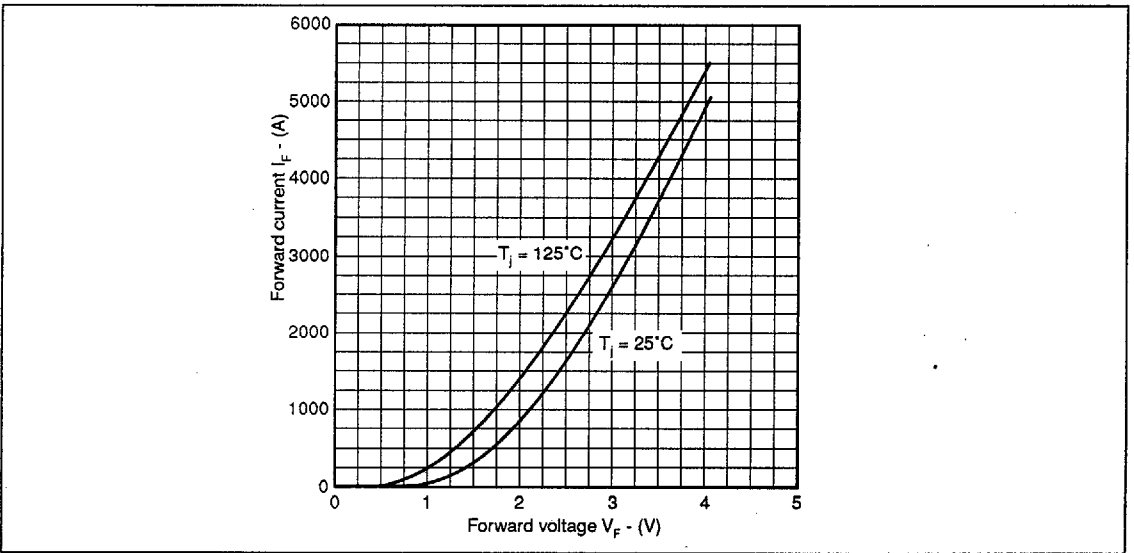
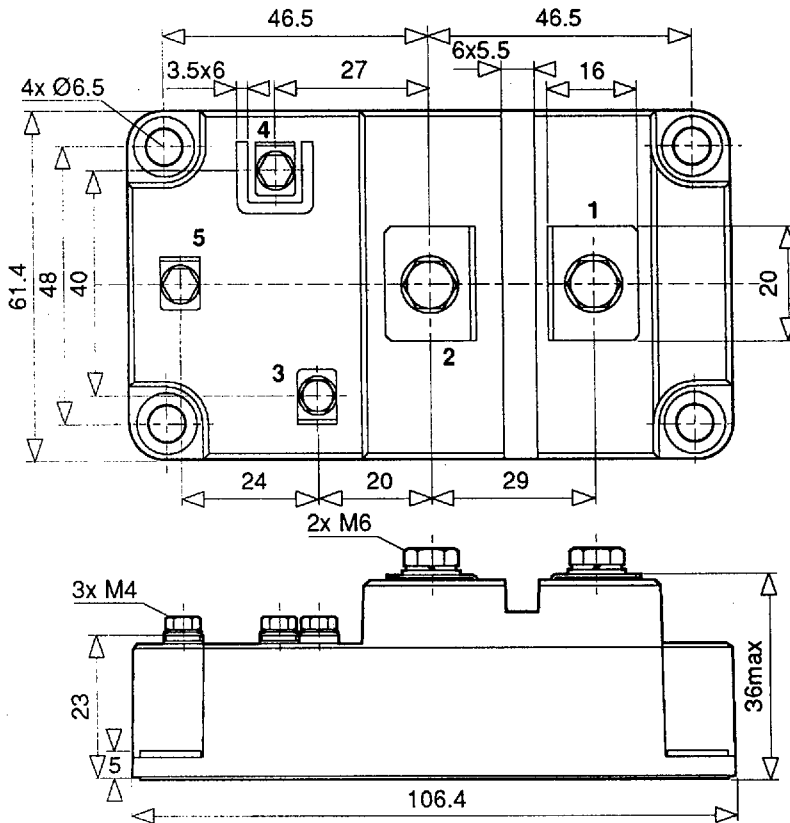
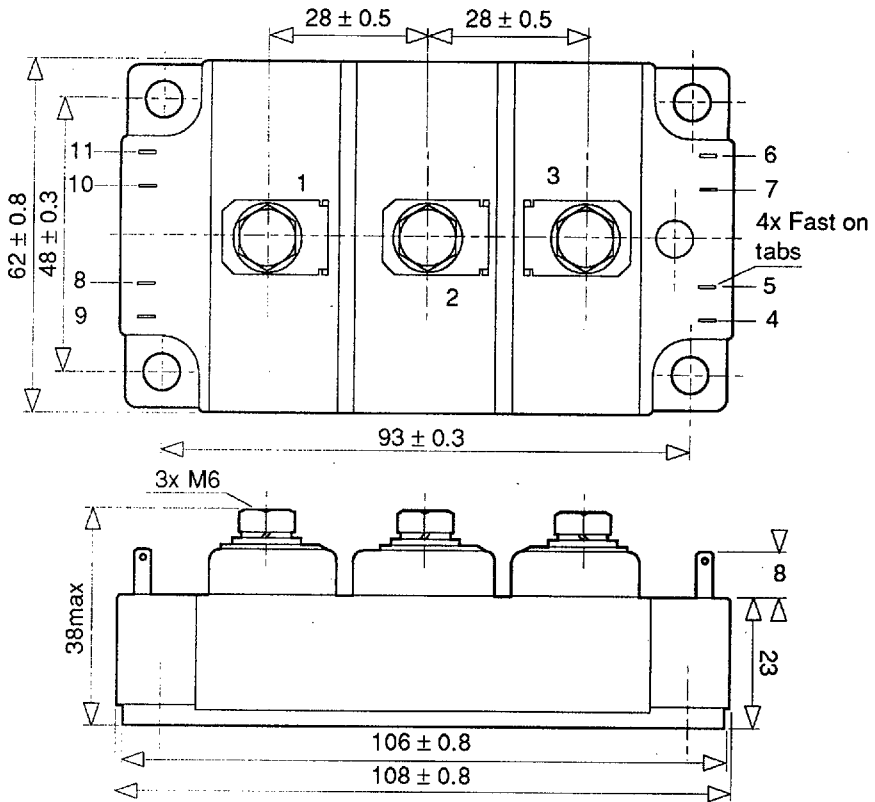

Fig.15 Typical diode forward characteristics



PACKAGE OUTLINE - L

Recommended fixings for mounting:	M6
Recommended mounting torque:	5Nm (44lbs.ins)
Recommended torque for electrical connections (M6):	5Nm (44lbs.ins)
Max. torque for electrical connections (M4):	2Nm (18lbs.ins)
Nominal weight:	265g



PACKAGE OUTLINE - M

Recommended fixings for mounting:	M6
Recommended mounting torque:	5Nm (44lbs.ins)
Recommended torque for electrical connections (M6):	5Nm (44lbs.ins)
Max. torque for electrical connections:	8Nm (70lbs.ins)
Nominal weight:	265g

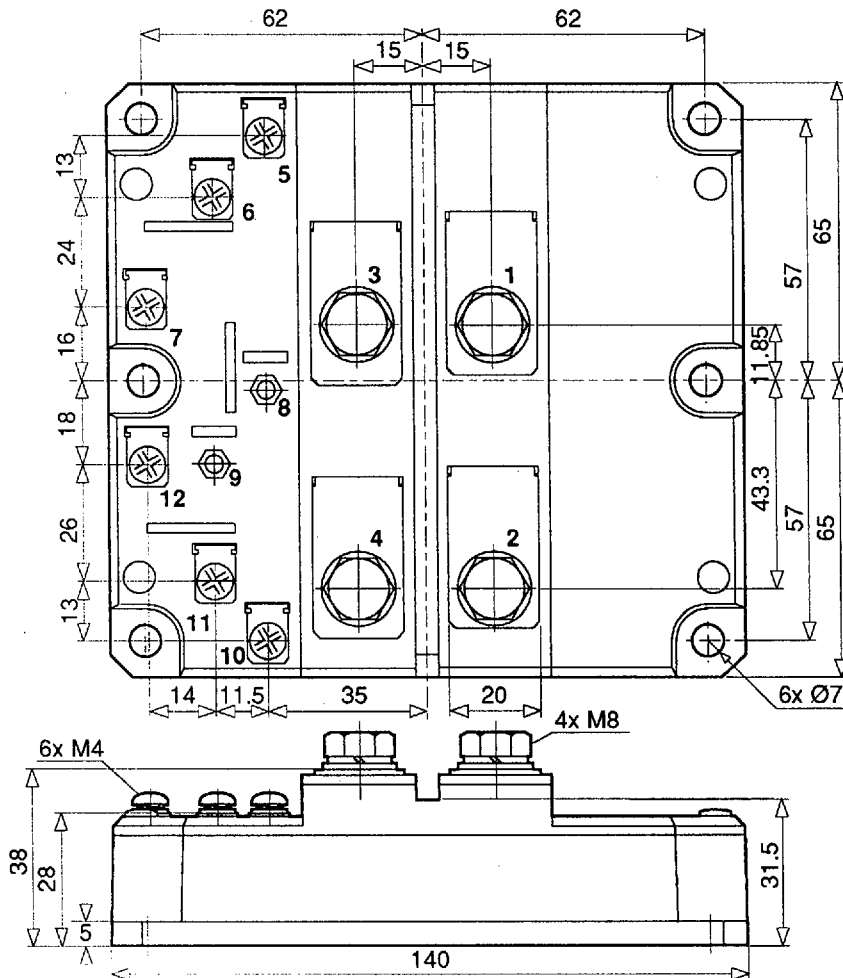

PACKAGE OUTLINE - D

- Recommended fixings for mounting: M6
 Recommended mounting torque: 5Nm (44lbs.ins)
 Recommended torque for electrical connections (M8): 8Nm (70lbs.ins)
 Max. torque for electrical connections (M8): 10Nm (88lbs.ins)
 Recommended torque for electrical connections (M4): 2Nm (18lbs.ins)

Nominal weight: 1500g

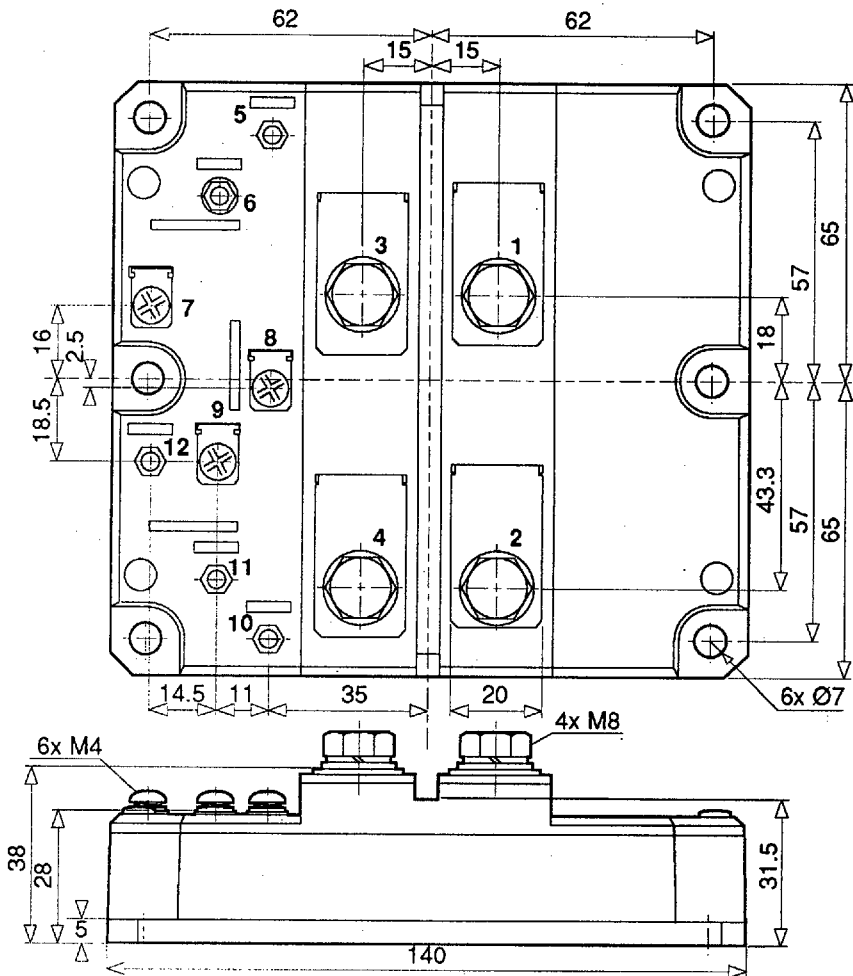

PACKAGE OUTLINE F

- Recommended fixings for mounting: M6
- Recommended mounting torque: 5Nm (44lbs.ins)
- Recommended torque for electrical connections (M8): 8Nm (70lbs.ins)
- Max. torque for electrical connections (M8): 10Nm (88lbs.ins)
- Recommended torque for electrical connections (M4): 2Nm (18lbs.ins)

Nominal weight: 1500g