

LOC	DIST	REVISIONS					
E	B	P	LTR	DESCRIPTION	DATE	DWN	APVD
		B		ECO-09-003420	10 Mar 09	RITA	BOB

NOTES

- ① 100 TRAY PACK IN ACCORDANCE WITH AMP SPEC 107-3275
- ② SINGLE PACK IN ACCORDANCE WITH AMP SPEC 107-3275
- ③ Au PLATING OVER Ni PLATING OVER Cu PLATING
- ④ Ni PLATING OVER Cu PLATING
- 5. FOR TECHNICAL DATA REFER TO YOUR LOCAL TYCO ELECTRONICS SALES OFFICE
- 6. ALL DIMENSIONS ARE NOMINAL FOR REFERENCE ONLY UNLESS OTHERWISE STATED

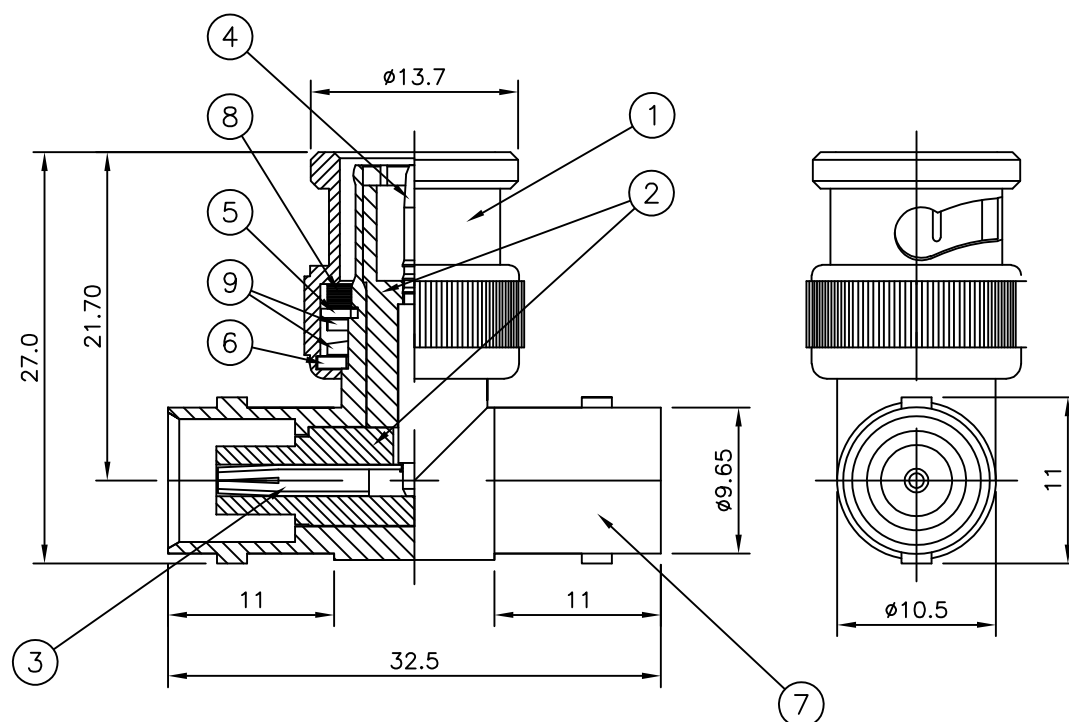
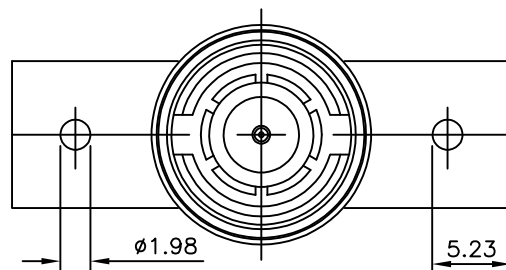

QTY	QTY	MATERIAL	DESCRIPTION	ITEM
1	1	SPRING STEEL	SPRING	9
1	1	SILCON RUBBER	GASKET	8
1	1	ZINC ALLOY	③ BODY	7
1	1	BRASS	④ WASHER	6
1	1	BRASS	⑤ CIRCLIP	5
1	1	BRASS	③ MALE CONTACT	4
1	1	PHOSPHOR BRONZE	③ FEMALE CONTACT	3
2	2	PE-606	INSULATOR	2
1	1	ZINC ALLOY	④ SHELL	1
5--1	5--0	MATERIAL	DESCRIPTION	ITEM
△	△			

THIS DRAWING IS A CONTROLLED DOCUMENT.		DWN RITA ZUO 10 Mar 09	Tyco Electronics Corporation Kunshan, Jiangsu, PRC 215312		
DIMENSIONS: MM		CHK ANSON MA 10 Mar 09	NAME BNC T-ADAPTOR 50 OHMS		
TOLERANCES UNLESS OTHERWISE SPECIFIED:		APVD BOB ZHAO 10 Mar 09	PRODUCT SPEC 108-112000		
0 PLC ± 0.5		APPLICATION SPEC			
1 PLC ± 0.3		SIZE A3			
2 PLC ± 0.2		CAGE CODE 00779			
3 PLC ± -		DRAWING NO C-1634532			
4 PLC ± -		RESTRICTED TO			
ANGLES ± -		WEIGHT -			
MATERIAL SEE TABLE		CUSTOMER DRAWING			
FINISH SEE TABLE		SCALE NTS			
		SHEET 1 OF 1			
		REV B			